



FEATURES

Single phase pumps now have built-in overload protection. See control panel note on page 3.

Impeller: Silicon bronze, multi-vane semi-open, with pump-out vanes for mechanical seal protection. Balanced for smooth operation.

Grinder Cutter System: The anti-roping design, hardened cutter is keyed to the motor shaft for positive drive. The cutter ring is specially designed to be reversed when the first side wears out thus doubling its life and reducing maintenance costs. The cutter system is designed and tested to pass items found in normal wastewater.

Casing: Heavy duty cast iron, volute type for maximum efficiency. Use with A10-12 guide rail system for ease of installation and maintenance.

Dual Mechanical Seals: Silicon carbide vs. silicon carbide outer seal and ceramic vs. carbon inner seal, stainless steel metal parts, BUNA-N elastomers. Upper and lower shaft seals are positioned independently and are separated by an oil-filled chamber. Optional Silicon/Tungsten Carbide outer seal available.

Optional Seal Sensor Probe: Located in oil-filled chamber. If pumpage should begin to leak past lower seal it indicates to pump control panel a fault has occurred. Requires optional Seal Fail Circuit in the control panel.

Fasteners and Pipe Plugs: 300 series stainless steel.

AGENCY LISTINGS



Tested to UL 778 and CSA 22.2 108 Standards
By Canadian Standards Association
File #LR38549

1GD

SUBMERSIBLE GRINDER PUMP

DUAL SEAL WITH OPTIONAL SEAL SENSOR PROBE



APPLICATIONS

Designed for high head sewage applications where a gravity system is not practical. Ideal for pressure sewage systems.

SPECIFICATIONS

Pump:

- Solids handling capabilities: 3" maximum
- Discharge: 1¼" NPT removable flange
- Capacities: up to 46 GPM
- Total heads: up to 106 feet TDH

Motor:

- 2 HP, 3450 RPM, 60 Hz
- Class "F" insulation
- Rated for continuous duty fully submerged
- Maximum Fluid Temperature:
104° F continuous duty, 140° F intermittent duty

Single Phase:

- 208 or 230 volt
- Built-in, auto reset, on-winding motor overload

Three Phase:

- 200, 230, 460 or 575 volt
- Class 10 ambient compensated, overload protection required in control panel.

NOMENCLATURE DESCRIPTION

1st, 2nd and 3rd Characters - Discharge Size and Type

1GD = 1¼" discharge, grinder, dual seal

4th Character - Mechanical Seals

5 = silicon carbide/silicon carbide/BUNA - lower seal and carbon/ceramic/BUNA - upper seal (standard)

3 = silicon carbide/tungsten carbide/BUNA - lower seal and carbon/ceramic/BUNA - upper seal (optional)

5th Character - Cycle/RPM

1 = 60 Hz/3500 RPM 5 = 50 Hz/2900 RPM

6th Character - Horsepower

G = 2 HP

7th Character - Phase/Voltage

1 = single phase, 230 V 5 = three phase, 575 V
2 = three phase, 200 V 6 = three phase, 380 V
3 = three phase, 230 V 8 = single phase, 208 V
4 = three phase, 460 V

MOTORS

- Fully submerged in oil-filled chamber. High grade turbine oil surrounds motor for more efficient heat dissipation, permanent lubrication of bearings and mechanical seal for complete protection against outside environment.
- Class F insulation
 - **Single Phase:** 2 HP, 208 or 230 volt, 60 Hertz, 3450 RPM, 14/4 power cord. Motor has built-in overload with automatic reset. Start capacitor, run capacitor and starting relay are required and will be located in the control panel. See "Recommended Control Panels" in chart on this bulletin.
 - **Three Phase:** 2 HP, 200, 230, 460 or 575 V, 60 Hz, 3450 RPM. 14/4 STOW. Overload protection must be provided in starter unit.
- **Designed for Continuous Operation:** Pump ratings are within the motor manufacturer's recommended working limits and can be operated continuously without damage when fully submerged.
- **Bearings:** Upper and lower heavy duty ball bearing construction for precision positioning of parts and to carry thrust loads.
- **Power (Sensor) Cables:** Severe duty rated, oil and water resistant. Epoxy seal on motor end provides secondary moisture barrier in case of outer jacket damage and to prevent oil wicking. 20 foot standard with optional lengths available.
- **O-ring:** Assures positive sealing against contaminants and oil leakage.
- **Shaft:** 300 series stainless steel, keyed design, short overhang for minimum shaft deflection.
- Pump is capable of running dry without damage to mechanical components.

8th Character - Impeller Diameter

A = 5½", Standard C = 4¾"
B = 5¼" D = 4¼"

9th Character - Cord Length (Power and Sensor)

A = 20' (standard) F = 50'
D = 30' J = 100'

10th Character - Options

S = Seal fail, moisture sensing circuit¹
E = Epoxy paint

Last Character - Option

H = Pilot duty thermal sensors¹ (**3 phase only!!**)

¹These options add a 2-wire or 4-wire sensor cord to the pump and require optional control panel circuits to operate. See panel options on control panel bulletin BCP5.

MODEL AND MOTOR INFORMATION

| Order No. | HP | Phase | Volts | RPM | Maximum Amps | Locked Rotor Amps | KVA Code | Full Load Efficiency | Resistance | | Power Cord | Weight lbs. |
|-----------|----|-------|-------|------|--------------|-------------------|----------|----------------------|------------|-----------|-----------------------------|-------------|
| | | | | | | | | % | Start | Line-Line | | |
| 1GD51G1AA | 2 | 1 | 230 | 3450 | 15.5 | 96.0 | P | 79.0 | 1.37 | 0.62 | 14/4 STOW 20' LONG | 110 |
| 1GD51G8AA | | | 208 | | 17.5 | | | | | | | |
| 1GD51G2AA | | 3 | 200 | | 14.0 | 44.8 | J | 81.0 | NA | 1.8 | | |
| 1GD51G3AA | | | 230 | | 12.0 | 37.4 | D | 81.4 | | 2.8 | | |
| 1GD51G4AA | | | 460 | | 6.0 | 18.7 | | | | 11.1 | | |
| 1GD51G5AA | | | 575 | | 4.8 | 14.0 | J | 83.2 | | 18.0 | | |

FEATURES (continued)

Effective with December 2005 (M05) Date Codes -

Single-Phase 1GD Pumps Contain a Built-in, Auto Reset Overload.

Important Control Panel Requirements and Notes:

- 1) See panel bulletin BCP5 for other available options.
- 2) These pumps require a magnetic contactor, start and run capacitors and a starting relay in the control panel.
- 3) CP-1GDB Capacitor packs with starting relays are available on product bulletin BCPCAP. They are for certified panel shops to "build" into a custom panel. Field installing capacitor packs into a S10020 or D10020 will negate the UL listing on that panel and is therefore not permissible.

| Pump Order No. | Pump Seal Fail Circuit | Voltage / Phase | Recommended Control Panel | |
|----------------|------------------------|-----------------|---------------------------|--------|
| | | | Simplex | Duplex |
| 1GD51G1A- | No | 230 / 1 | S1GD2 | D1GD2 |
| 1GD51G8A- | | 208 / 1 | S1GD2 | D1GD2 |
| 1GD51G1A-S | Yes | 230 / 1 | S1GD2H | D1GD2J |
| 1GD51G8A-S | | 208 / 1 | S1GD2H | D1GD2J |

MATERIALS OF CONSTRUCTION

| Item No. | Part Name | | Material Standard | | | | |
|----------|------------------|----------------------|-------------------|-------------------------------|------------------|------------|---------------|
| | 1 | Impeller, multi-vane | | 1179 | | | |
| 2 | Castings | | 1003 | | | | |
| 3 | Shaft-Keyed | | 300 Series SS | | | | |
| 4 | Fasteners | | 300 Series SS | | | | |
| 5 | Ball bearings | | Steel | | | | |
| 6 | Power cable | | STOW, 20 feet | | | | |
| 7 | O-ring | | BUNA-N | | | | |
| 8 | Outer Mech. Seal | No. | Service | Rotary | Stationary | Elastomers | Metal Parts |
| | OPT | 10K22 | Heavy duty | Silicon Carbide | Tungsten Carbide | BUNA-N | 300 Series SS |
| | STD | 10K28 | Mild abrasives | Silicon Carbide | | BUNA-N | 300 Series SS |
| | | Material Code | | Engineering Standard | | | |
| | | 1003 | | Cast iron – ASTM A48 Class 30 | | | |
| | | 1179 | | Silicon bronze – ASTM C87600 | | | |

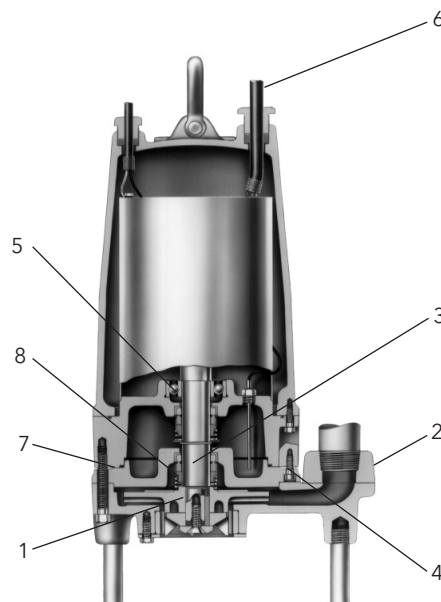

APPLICATION DATA

| | |
|-----------------------------------|--|
| Maximum Solid Size | N/A |
| Minimum Casing Thickness | 5/16" |
| Casing Corrosion Allowance | 1/8" |
| Maximum Working Pressure | 50 PSI |
| Maximum Submergence | 50 feet |
| Minimum Submergence | Fully submerged for continuous operation |
| | 6" below top of motor for intermittent operation |
| Maximum Environmental Temperature | 40°C (104°F) continuous operation |
| | 60°C (140°F) intermittent operation |

CONSTRUCTION DETAILS

| | |
|--|---|
| Power Cable - Type | 14/3, type SJTOW: single phase |
| | 14/4, type STOW: single phase |
| | 14/4, type STOW: all three phase |
| Sensor Cable - Type | 16/2, type SJTOW: heat sensor or seal fail only |
| | 18/4, type SJTOW: seal/heat sensor |
| Motor Cover | Gray Cast Iron - ASTM A48 Class 30 |
| Bearing Housing | Gray Cast Iron - ASTM A48 Class 30 |
| Seal Housing | Gray Cast Iron - ASTM A48 Class 30 |
| Casing | Gray Cast Iron - ASTM A48 Class 30 |
| Impeller | Cast Bronze - ASTM B584 C87600 |
| Motor Shaft | AISI 300 Series Stainless Steel |
| Motor Design | NEMA 56 Frame, oil filled with Class F Insulation |
| Optional: Motor Seal Fail (Moisture) Detection | Seal fail sensor in an oil-filled seal chamber. Connect to an optional relay in control panel. |
| Optional: Motor Thermal Protection 1Ø and 3Ø | Normally closed on-winding thermostats open at 275° F (135° C) and close at 112° F (78° C). Require terminal connection in the control panel. |
| Motor Overload Protection | Single Phase: Built-in, auto reset overload |
| | Three Phase: require ambient compensated Class 10 protection in the control panel. |
| External Hardware | 300 Series Stainless Steel |
| Impeller Type | Semi-open with pump out vanes on back shroud |
| Cutter | Two blades; type 440C stainless steel |
| Oil Capacity - Seal Chamber | 1.5 quarts |
| Oil Capacity - Motor Chamber | 4.5 quarts |

STANDARD PARTS

| | |
|-----------------------------|--|
| Ball Bearing - Upper | Single row ball- SKF™ 6203-2Z |
| Ball Bearing - Lower | Single row ball - SKF™ 6206-2Z |
| Mechanical Seals - Standard | Carbon/Ceramic; Upper |
| | Silicon Carbide/Silicon Carbide - Lower |
| Mechanical Seals - Optional | Silicon Carbide/Tungsten Carbide - Lower |
| O-Ring - Stuffing Box | BUNA-N, AS 568A-256 |
| O-Ring - Motor Cover | BUNA-N, AS 568A-166 |

DIMENSIONS

(All dimensions are in inches. Do not use for construction purposes.)

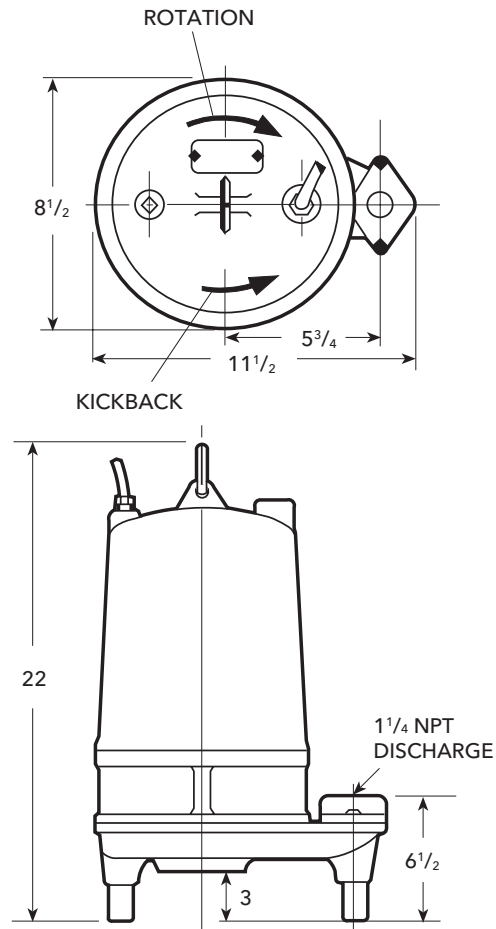

xylem
Let's Solve Water

Xylem Inc.
2881 East Bayard Street Ext., Suite A
Seneca Falls, NY 13148
Phone: (866) 325-4210
Fax: (888) 322-5877
www.gouldswatertechnology.com

Goulds is a registered trademark of Goulds Pumps, Inc. and is used under license.
© 2016 Xylem Inc. B1GD R3 February 2016