

Industrial Drum Pump Packages

PUMP PACKAGE 6

Mineral Acids

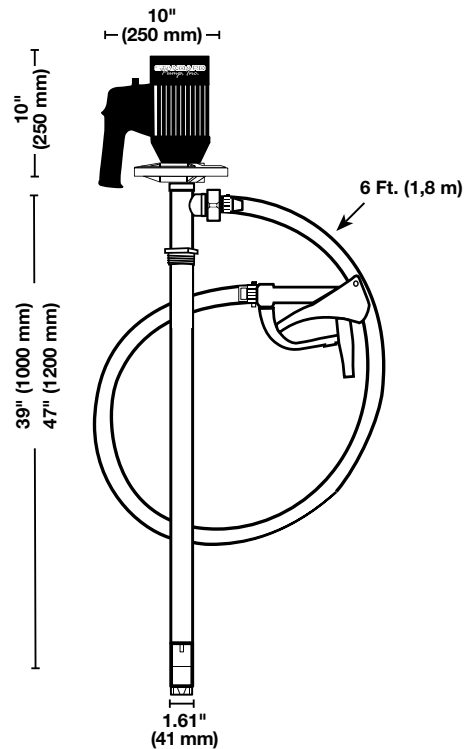

Technical Specifications

- Package:Motor, Pump, Hose, Storage Bracket
Barrel Adapter & Hand Nozzle
- Motor Type:Open Drip Proof (IP 44)
- Pump Assembly:SS316
- Pump Length:..... 39" (1000 mm) or 47" (1200 mm)
- Discharge Hose:..... PVC, 6 ft (1,8 m), 1" (25 mm) I.D.
- Hand Nozzle: SS316, 1" (25 mm)
- Maximum Flow Rate:..... 21 GPM (79 LPM) *based on water*
- Maximum Viscosity: 1500 cps (mPas)
- Maximum Temperature:175° F (80° C)
- Shipping Weight:..... 32 lbs. (14,51 kg)

Package Numbers:

Drums:

Pkg P/N	Motor	Volts	Pump Tube
9414	SP-280P-V	110V	SP-SS-39
9415	SP-280P-2-V	220V	SP-SS-39

Tanks:

Pkg P/N	Motor	Volts	Pump Tube
9416	SP-280P-V	110V	SP-SS-47
9417	SP-280P-2-V	220V	SP-SS-47

STANDARD
Pumps, Inc.

www.standardpump.com

Toll Free: 1-866-558-8611

Tel 770-307-1003