

Industrial Drum Pump Packages

PUMP PACKAGE 9 Flammable & Combustible Liquids

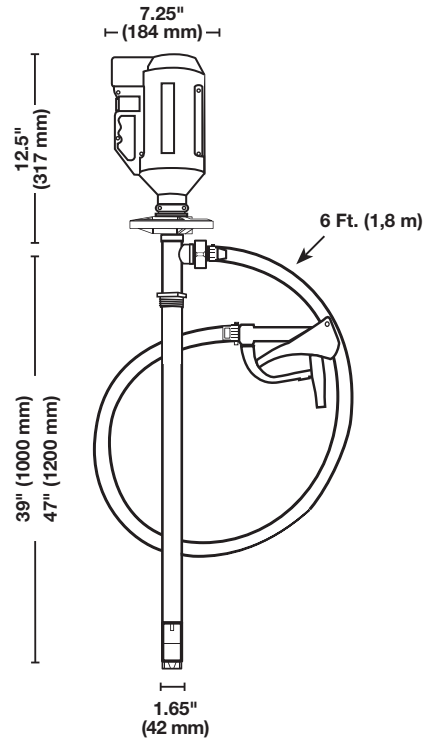

Technical Specifications

Package:Motor, Pump, Hose, Storage Bracket
Barrel Adapter & Hand Nozzle

Motor Type: EXP (IP 54)

Pump Assembly: SS316

Pump Length:..... 39" (1000 mm) or 47" (1200 mm)

Discharge Hose:.....Solvent Hose, 6 ft (1,8 m), 1" (25 mm) I.D.

Hand Nozzle: SS316, 1" (25 mm)

Maximum Flow Rate:
 9611, 9613 18 GPM (68 LPM) *based on water*
 9610, 9612 11.5 GPM (43,5 LPM) *based on water*

Maximum Viscosity:
 9611, 9613 750 cps (mPas)
 9610, 9612 200 cps (mPas)

Maximum Temperature:175° F (80° C)

Shipping Weight:..... 40 lbs. (18,6 kg)

Package Numbers:

Drums:

Pkg P/N	Motor	Volts	Pump Tube
9610	SP-410EX	110V	SP-SS-39
9611	SP-420EX	220V	SP-SS-39

Tanks:

Pkg P/N	Motor	Volts	Pump Tube
9612	SP-410EX	110V	SP-SS-47
9613	SP-420EX	220V	SP-SS-47

STANDARD
Pumps, Inc.

www.standardpump.com

Toll Free: 1-866-558-8611

Tel 770-307-1003