

Technical Specifications

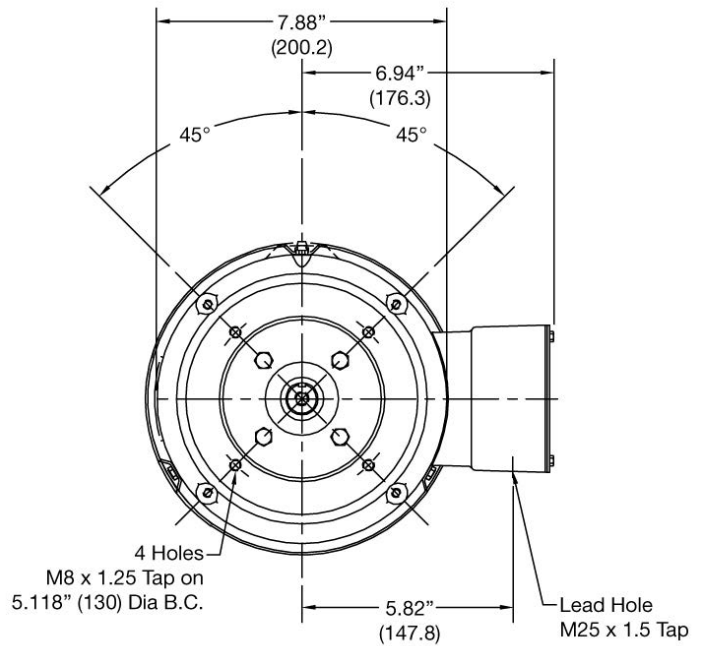

Enclosure:	TEFC (IP55)
Washdown:	Yes
Voltage:	190/380//230/460
Horsepower (KW):	1 (.75)
Phase:	3
Amps:	4.6/2.3//4.2/2.1
Frequency:	50-60 Hz
Insulation Class:	F
Power Factor65
Frame:	D100LC
RPM:	750-900
Noise Level:	70 dBa
Certification:	UL & CSA
Weight:61 lbs (27,7 kg)

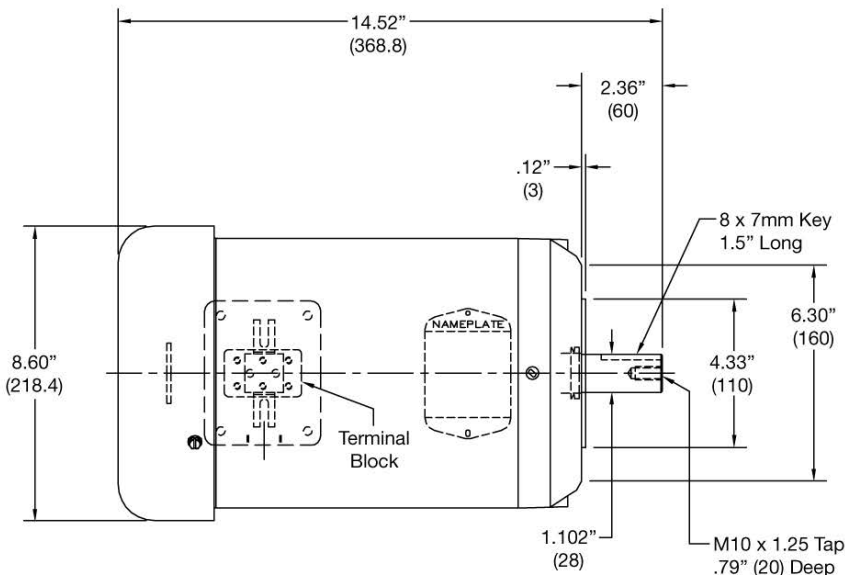

WARNING: Not suitable for pumping flammable or combustible liquids or use in a hazardous duty environment.

Note: Only compatible with the SP-700DD or 800DD Series pump.