

MTR, CRK, SPK

Installation and operating instructions



Original installation and operating instructions.

CONTENTS

	Page
1. Limited Warranty	3
2. Symbols used in this document	3
3. Handling	3
4. Applications	3
4.1 Pumped liquids	3
5. Type designation	4
5.1 Pump key for MTR	4
5.2 Pump key for CRK and SPK	4
6. Technical data	4
6.1 Ambient temperature	4
6.2 Electrical data	4
6.3 Frequency of starts and stops	4
6.4 Maximum permissible operating pressure and liquid temperature for the shaft seal	5
6.5 Minimum flow rate	5
7. Installation	5
7.1 Pump location	5
7.2 Suction conditions	6
8. Electrical connection	6
8.1 Frequency converter operation	7
9. Start-up	7
10. Maintenance	7
10.1 Lubrication	7
10.2 Filters	7
10.3 Periodic checks	8
11. Service	8
11.1 Service kits	8
11.2 Coupling adjustment	8
12. Sound pressure level	8
13. Disposal	8
14. Fault finding chart	9



Prior to installation, read these installation and operating instructions. Installation and operation must comply with local regulations and accepted codes of good practice.

1. Limited Warranty

Products manufactured by GRUNDFOS PUMPS CORPORATION (Grundfos) are warranted to the original user only to be free of defects in material and workmanship for a period of 24 months from date of installation, but not more than 30 months from date of manufacture. Grundfos' liability under this warranty shall be limited to repairing or replacing at Grundfos' option, without charge, FOB Grundfos' factory or authorized service station, any product of Grundfos' manufacture. Grundfos will not be liable for any costs of removal, installation, transportation, or any other charges which may arise in connection with a warranty claim. Products which are sold but not manufactured by Grundfos are subject to the warranty provided by the manufacturer of said products and not by Grundfos' warranty. Grundfos will not be liable for damage or wear to products caused by abnormal operating conditions, accident, abuse, misuse, unauthorized alteration or repair, or if the product was not installed in accordance with Grundfos' printed installation and operating instructions.

To obtain service under this warranty, the defective product must be returned to the distributor or dealer of Grundfos' products from which it was purchased together with proof of purchase and installation date, failure date, and supporting installation data. Unless otherwise provided, the distributor or dealer will contact Grundfos or an authorized service station for instructions.

Any defective product to be returned to Grundfos or a service station must be sent freight prepaid; documentation supporting the warranty claim and/or a Return Material Authorization must be included if so instructed.

GRUNDFOS WILL NOT BE LIABLE FOR ANY INCIDENTAL OR CONSEQUENTIAL DAMAGES, LOSSES, OR EXPENSES ARISING FROM INSTALLATION, USE, OR ANY OTHER CAUSES. THERE ARE NO EXPRESS OR IMPLIED WARRANTIES, INCLUDING MERCHANTABILITY OR FITNESS FOR A PARTICULAR PURPOSE, WHICH EXTEND BEYOND THOSE WARRANTIES DESCRIBED OR REFERRED TO ABOVE.

Some jurisdictions do not allow the exclusion or limitation of incidental or consequential damages and some jurisdictions do not allow limit actions on how long implied warranties may last. Therefore, the above limitations or exclusions may not apply to you. This warranty gives you specific legal rights and you may also have other rights which vary from jurisdiction to jurisdiction.

2. Symbols used in this document



Warning

If these safety instructions are not observed, it may result in personal injury.

3. Handling



The motors of the MTR 1s to 64, CRK 2 to 4, and SPK 1 to 8, pumps are supplied with lifting eyes which must not be used for lifting the entire pump.

When the entire pump is to be lifted, observe the following:

- MTR 1s to 64, CRK 2 to 4, and SPK 1 to 8 pumps fitted with motors 10 HP [7.5 kW] and smaller should be lifted by the pump head by means of straps or the like.
- MTR 15 to 64 fitted with motors 15 HP [11 kW] and larger should be lifted by means of the lifting devices fitted to the motor and the motor stool.
- For other motor makes than those mentioned above, it is recommended to lift the pump in the pump head by means of straps.

4. Applications

The Grundfos pumps, types MTR, CRK, and SPK are multistage centrifugal pumps designed for pumping liquids for machine tools, condensate transfer, liquid transfer in industrial washing machines and similar applications.



The pump must not be used for the transfer of inflammable liquids such as diesel oil and petrol.

4.1 Pumped liquids

Thin, non-explosive liquids, not containing fibres. The liquid must not attack the pump materials chemically.

When pumping liquids with a density and/or viscosity higher than that of water, motors with correspondingly higher outputs must be used, if required.

4.1.1 MTR/CRK/SPK

MTR/CRK/SPK pumps are used for liquid transfer in machine tools and in all systems where a tank mounted pump is required. For liquid transfer, circulation and pressure boosting of cold or hot clean liquids.

4.1.2 MTRI/CRKI/SPKI

In systems where all parts in contact with the liquid must be made of high-grade stainless steel, MTRI, CRKI, and SPKI pumps must be used.

5. Type designation

The standard range of pumps encompasses complete impeller in chamber combinations. On request, other lengths, against duty combinations, can be supplied by fitting empty intermediate chambers instead of standard chambers with impellers.

The pump key on the pump nameplate indicates the number of chambers and impellers fitted to the pump.

5.1 Pump key for MTR

Example	MTR	32-	2	/1	-1	-A	-G	-A	-HUUV
Pump range									
Nominal flow rate in m ³ /h									
Number of stages									
Number of impellers									
Number of impellers with reduced diameter (MTR 32, 45, 64 only)									
Code for pump version									
Code for pipework connection									
Code for materials									
Code for shaft seal									

5.2 Pump key for CRK and SPK

Example	SPK	8 -	3 /	3 -A	-WB	-A	-AUUV
Pump range							
Nominal flow rate in m ³ /h							
Number of stages x 10 (SPK x 1)							
Number of impellers							
Code for pump version							
Code for pipework connection							
Code for materials							
Code for shaft seal and rubber pump parts							

6. Technical data

Pump type	MTR	CRK	SPK
Min liquid temperature °F [°C]	14 [-10]	14 [-10]	14 [-10]
Max liquid temperature °F [°C]	194 [90]	194 [90]	194 [90]
Max operating pressure psi [bar]	362 [25]	362 [25]	362 [25]
Enclosure class	TEFC	TEFC	TEFC

6.1 Ambient temperature

Maximum ambient temperature: 104°F [40°C]

If the ambient temperature exceeds above maximum values or if the motor is located 3280 ft [1000 m]. above sea level, the motor output (P2) must be reduced due to the low density and consequently low cooling effect of the air. In such cases, it may be necessary to use a motor with a higher output

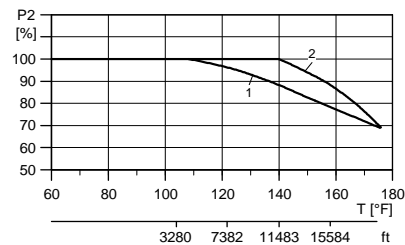

Fig. 1 Relationship between motor output (P2) and ambient temperature/altitude

Pos.	Description
1	Grundfos MLE and Baldor Motor
2	Grundfos ML Motors

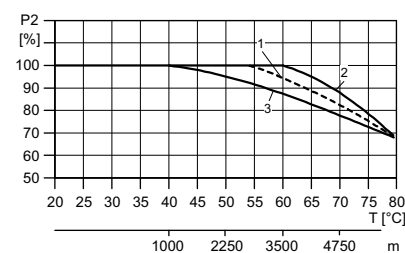

Fig. 2 Relationship between motor output (P2) and ambient temperature/altitude [metric]

Pos.	Motor Power [kW]	Motor make
1	0.37 - 0.55	ML
2	0.75 - 22	ML
3	0.37 - 22	MLE
	30 - 75	Siemens

Example:

From the above figure and key appears that P2 must be reduced to 88% when a pump with NEMA Premium Efficiency, ML motor is installed 15584 ft [4750 m]. above sea level. At an ambient temperature of 167°F [75°C], P2 must be reduced to 74% of rated output.

6.2 Electrical data

See motor nameplate.

6.3 Frequency of starts and stops

6.3.1 Grundfos ML motors:

250 times per hour for 1/3-3 HP (.37-2.2 kW)
 100 times per hour for 5 HP (3-4 kW)
 50 times per hour for 7.5-10 HP (5.5-7.5 kW)
 40 times per hour for 11-22 kW

6.3.2 Baldor Motors:

20 times per hour on 0.33-5 HP models
 15 times per hour on 7.5-15 HP models
 10 times per hour on 20-100 HP models

TM03 4272 2006

TM03 2479 2512

6.4 Maximum permissible operating pressure and liquid temperature for the shaft seal

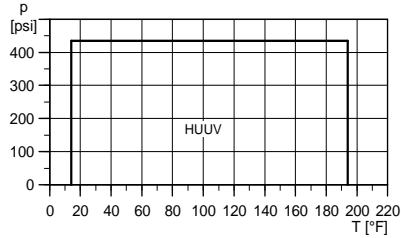

Fig. 3 MTR 1s to 64

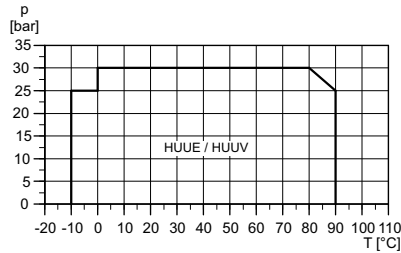

Fig. 4 MTR 1s to 64 [metric]

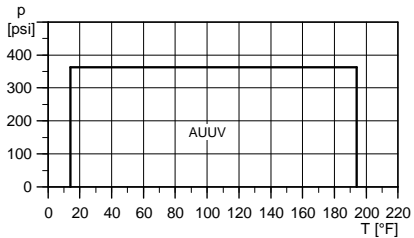

Fig. 5 CRK and SPK

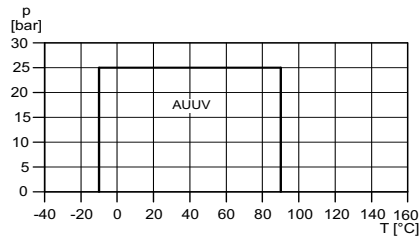

Fig. 6 CRK and SPK [metric]

6.5 Minimum flow rate

Due to the risk of overheating, the pump should **not** be used at flows below the minimum flow rate.

The curve below shows the minimum flow rate as a percentage of the nominal flow rate in relation to the liquid temperature.

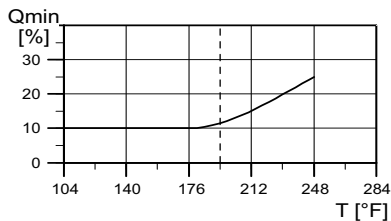

Fig. 7 Minimum flow rates

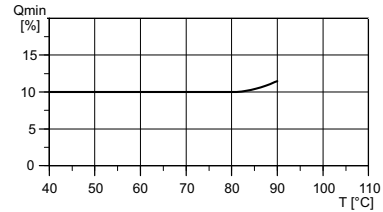

Fig. 8 Minimum flow rates [metric]

Note: The pump must never operate against a closed discharge valve.

7. Installation



The pump must be installed so that persons cannot accidentally come into contact with the hot surface of the motor.

7.1 Pump location

The pump is designed for tank mounting in vertical position. The pump is positioned in a hole cut into the cover of the tank (upper side) and is secured to the tank by four hexagon head screws through the holes in the mounting flange. It is recommended to fit a sealing gasket between the pump flange and tank.

If the pump is to be installed horizontally (MTR I[E] 1s to 20, CRK2 and 4, and SPK only), the drain hole of the motor stool must be fitted with a plug and four closed nuts with O-rings must be fitted to the straps.

Caution Tank must be drained to change shaft seal in the event of leakage in horizontally mounted pumps.

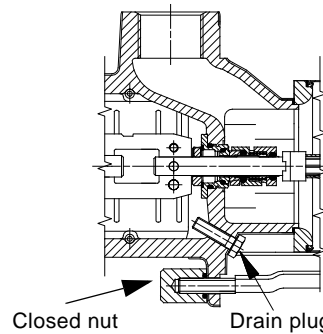

Fig. 9 Horizontal installation (MTR I[E] only)

Note: MTR 32, 45 and 64 pumps can only be installed in vertical position.

TM02 7853 2512

TM03 4270 2006

TM 07 7854 2512

TM03 4271 2006

TM 03 0022 2512

TM02 8043 4503

TM03 5343 3406

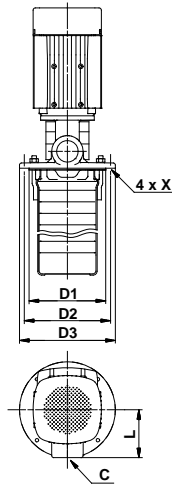

Fig. 10 Vertical installation

Pump mounting flange dimensions:

Pump type	Frame	D1	D2	D3	L	C	X
MTR 1s, 1, 3, 5	NEMA	5.51 [140]	6.30 [160]	7.09 [180]	3.94 [100]	1.25" NPT	ø0.37 [9.5]
MTR 10, 15, 20	NEMA	7.87 [200]	8.86 [225]	9.84 [250]	4.92 [125]	2" NPT	ø0.35 [9]
MTR 32	NEMA	7.48 [190]	8.66 [220]	9.84 [250]	5.91 [150]	2.5" ANSI	ø0.47 [12]
MTR 45, 64	NEMA	9.45 [240]	10.43 [265]	11.42 [290]	6.50 [165]	3.0" ANSI	ø0.47 [12]
CRK 2, 4	NEMA	5.51 [140]	6.30 [160]	7.09 [180]	3.94 [100]	1.25" NPT	ø0.37 [9.5]
SPK 1, 2, 4, 8	NEMA	5.51 [140]	6.30 [160]	7.09 [180]	3.94 [100]	1.25" NPT	ø0.37 [9.5]
CRK 2, 4	IEC	5.51 [140]	6.30 [160]	7.09 [180]	3.94 [100]	1.25" BSPT	ø0.30 [7.5]
SPK 1, 2, 4	IEC	3.94 [100]	4.53 [115]	5.12 [130]	2.52 [64]	0.75" BSPT	ø0.30 [7.5]
SPK 8	IEC	5.51 [140]	6.30 [160]	7.09 [180]	3.94 [100]	1.25" BSPT	ø0.30 [7.5]

7.2 Suction conditions

The bottom of the pump strainer must be at least 1 in [22 mm] above the bottom of the tank.

The pumps are designed to provide full performance down to a level of A above the bottom of the strainer.

At a liquid level between A and B above the bottom of the strainer, the built-in priming screw will protect the pump against dry running.

Note: MTR 32, 45 and 64 pumps have no priming screw.

Pump type	A in. [mm]	B in. [mm]
MTR 1s, 1, 3, 5, CRK 2, 4, and SPK 1, 2, 4, 8	1.6 [41]	1.1 [28]
MTR 10, 15, 20	2.0 [51]	1.0 [25]
MTR 32, 45, 64	2.8 [71]	–

TM02 8042 4503

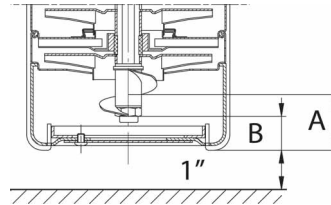

Fig. 11 MTR 1s, 1, 3, 5, CRK 2, 4, and SPK 1, 2, 4, 8

TM00 4841 3897

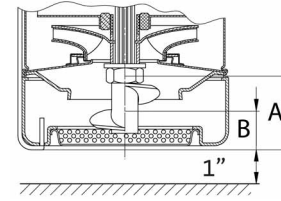

Fig. 12 MTR 10, 15, 20

TM00 4842 3897

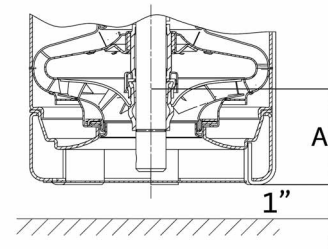

Fig. 13 MTR 32, 45, 64

TM01 4335 5298

Each pump inlet is protected by a strainer to prevent larger particles from entering and damaging the pump. If the pumped liquid contains solid particles larger than the size of the holes in the strainer, the passage of the strainer may be blocked. In such situations the performance will drop as a result of a reduced flow through the pump.

Note: If the suction strainer is removed from the retainer, solid particles may enter the pump and cause a seizure or even damage the pump.

In grinding applications Grundfos recommends that the pumped liquid is screened for abrasive particles before entering the pump. When pumped, abrasive particles reduce the life of the pump components. Wear of the pump components caused by abrasive particles starts when the concentration exceeds 20 ppm.

The table below describes the size of the passage in the strainer.

Pump type	Strainer passage ø in. [mm]
MTR(E) 1s to 3	0.08" [2]
MTR (E) 5 to 64	0.16" [4]
CRK and SPK	0.12" [3]

8. Electrical connection

The electrical connection should be carried out by an authorized electrician in accordance with local regulations.



Before removing the terminal box cover and before any removal/dismantling of the pump, make sure that the electricity supply has been switched off.

The pump must be connected to an external mains switch with a minimum contact gap of 0.125" [3.2mm] in all poles.

The operating voltage and frequency are marked on the pump nameplate. Please make sure that the motor is suitable for the electricity supply on which it will be used.

Single-phase Grundfos motors incorporate a thermal switch and require no additional motor protection.

Three-phase motors must be connected to a motor starter.

The terminal box can be turned to four positions, in 90° steps, see fig. 14:

1. If necessary, remove the coupling guards.
Do *not* remove the coupling.
2. Remove the bolts securing the motor to the pump.
3. Turn the motor to the required position.
4. Replace and tighten the bolts.
5. Replace the coupling guards.

The electrical connection should be carried out as shown in the diagram inside the terminal box cover.

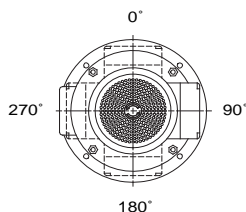

Fig. 14 Terminal box positions

8.1 Frequency converter operation

8.1.1 Motors supplied by Grundfos:

All three-phase motors supplied by Grundfos can be connected to a frequency converter.

Dependent on the frequency converter type, this may cause increased acoustic noise from the motor. Furthermore, it may cause the motor to be exposed to detrimental voltage peaks.

Note: Grundfos motors types ML 71 and 80 as well as ML 90 (2.0 Hp [1.5 kW], 2-pole), all for supply voltages up to and including 480 V or 440 V for ML (see motor nameplate), must be protected against voltage peaks higher than 650 V (peak value) between the supply terminals. It is recommended to protect all other motors against voltage peaks higher than 850 V.

The above disturbances, i.e. both increased acoustic noise and detrimental voltage peaks, can be eliminated by fitting an LC filter between the frequency converter and the motor.

For further information, please contact the frequency converter or motor supplier.

8.1.2 Other motor makes than those supplied by Grundfos:

Please contact the motor manufacturer.

9. Start-up



Pay attention to the direction of the vent hole (if equipped) and take care to ensure that the escaping water does not cause injury to persons or damage to the motor or other components.

9.0.1 Before starting the pump, make sure:

- that all pipe connections are tight.
- that the pump body is partly filled with liquid (partly submerged).
- that the strainer is not blocked by impurities.

9.0.2 Start the pump as follows:

1. Close the isolating valve on the discharge side of the pump.
2. If the pump is fitted with a vent valve, this valve must be opened, see fig. 15.

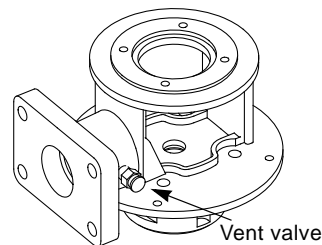

Fig. 15

3. See the correct direction of rotation of the pump on the motor fan cover or on the coupling guard. When seen from the top, the pump should rotate *counter-clockwise*.
4. Start the pump and check the direction of rotation.
5. Open the discharge isolating valve a little.
6. If the pump is fitted with a vent valve, this valve must be closed when a steady stream of liquid runs out of it.
7. Completely open the discharge isolating valve.

The pump has now been vented and is ready for operation.

Note: The pump is not allowed to run against a closed discharge valve for more than approx. 5 minutes as this will cause an increase in temperature/formation of steam in the pump which may cause damage to the pump.

10. Maintenance



Before starting work on the pump, make sure that all power supplies to the pump have been switched off and that they cannot be accidentally switched on.

Pumps installed in accordance with these instructions require very little maintenance.

10.1 Lubrication

The mechanical shaft seal is self-adjusting and has wear-resistant seal rings which are lubricated and cooled by the pumped liquid.

The pump bearings are also lubricated by the pumped liquid. Most motor ball bearings are grease packed and sealed for life. No further lubrication is necessary.

If the pump is to be drained for a long period of inactivity, remove one of the coupling guards to inject a few drops of silicone oil on the shaft between the pump head and the coupling. This will prevent the shaft seal faces from sticking.

10.1.1 Motor bearings:

Motors which are not fitted with grease nipples are maintenance-free.

Motors fitted with grease nipples should be lubricated with a high-temperature lithium-based grease, see the motor nameplate.

10.2 Filters

Chip trays, filters, etc. should be cleaned at regular intervals to ensure a correct flow of liquid.

TM01 6428 2399

TM00 4257 2294

10.3 Periodic checks

At regular intervals, depending on the conditions and time of operation, the following checks should be made:

- Check the quantity of liquid and operating pressure.
- Check that there are no leaks.
- Check that the motor is not overheating.
- Check the tripping of the motor starter.
- Check that all controls are operating satisfactorily.

If the above checks do not reveal any abnormal operating details, no further checks are necessary.

Should any faults be found, check the symptoms with section 14. *Fault finding chart*.

11. Service

Note: If a pump has been used for a liquid which is injurious to health or toxic, the pump will be classified as contaminated. If Grundfos is requested to service the pump, Grundfos must be contacted with details about the pumped liquid, etc. *before* the pump is returned for service. Otherwise Grundfos can refuse to accept the pump for service.

Possible costs of returning the pump are paid by the customer. However, any application for service (no matter to whom it may be made) must include details about the pumped liquid if the pump has been used for liquids which are injurious to health or toxic.

11.1 Service kits

Service kits for MTR, CRK, and SPK, see www.grundfos.com (WebCAPS), WinCAPS or Service Kit Catalogue.

11.2 Coupling adjustment

For adjustment of coupling on MTR 1s to 20, CRK, or SPK see page 10. For adjustment of coupling on MTR 32, 45, 64, see page 11.

12. Sound pressure level

Motor [Hp]	$\bar{d}B(A)$	
	50 Hz	60 Hz
0.5	<70	<70
0.75	<70	<70
1.0	<70	<70
1.5	<70	<70
2.0	<70	71
3.0	<70	71
4.0	<70	71
5.0	73	71
7.5	73	78
10	73	78
15	80	84
20	72	77
25	72	77
30	70	75
40	70	84

13. Disposal

Disposal of this product must be carried out according to the following guidelines:

1. Use the local public or private waste collection service.

2. In case such waste collection service does not exist or cannot handle the materials used in the product, please deliver the product or any hazardous materials from it to your nearest Grundfos company or service workshop.

14. Fault finding chart



Before starting work on the pump, make sure that the electricity supply has been switched off and that it cannot be accidentally switched on.

Fault	Cause	Remedy
1. Motor does not run when started.	a) Supply failure.	Connect the electricity supply.
	b) Fuses are blown.	Replace fuses.
	c) Motor starter overload has tripped out.	Reactivate the motor protection.
	d) Thermal protection has tripped out.	Reactivate the thermal protection.
	e) Main contacts in motor starter are not making contact or the coil is faulty.	Replace contacts or magnetic coil.
	f) Control circuit is defective.	Repair the control circuit.
	g) Motor is defective.	Replace the motor.
2. Motor starter overload trips out immediately when supply is switched on.	a) One fuse/automatic circuit breaker is blown.	Cut in the fuse.
	b) Contacts in motor starter overload are faulty.	Replace motor starter contacts.
	c) Cable connection is loose or faulty.	Fasten or replace the cable connection.
	d) Motor winding is defective.	Replace the motor.
	e) Pump mechanically blocked.	Remove the mechanical blocking of the pump.
	f) Overload setting is too low.	Set the motor starter correctly.
3. Motor starter overload trips out occasionally.	a) Overload setting is too low.	Set the motor starter correctly.
	b) Low voltage at peak times.	Check the electricity supply.
4. Motor starter has not tripped out but the pump does not run.	a) Supply failure.	Connect the electricity supply.
	b) Fuses are blown.	Replace fuses.
	c) Thermal protection has tripped out.	Reactivate the thermal protection.
	d) Main contacts in motor starter are not making contact or the coil is faulty.	Replace contacts or magnetic coil.
5. Pump runs but gives no liquid or pump capacity is not constant.	a) Pump strainer partly blocked by impurities.	Clean the strainer.
	b) Liquid level in tank too low.	Increase the liquid level.
	c) Pump draws in air.	Check the suction conditions.
6. Leakage in shaft seal.	a) Shaft seal is defective.	Replace the shaft seal.
7. Noise.	a) Cavitation occurs in the pump.	Check the suction conditions.
	b) Pump does not rotate freely (frictional resistance) because of incorrect pump shaft position.	Adjust the pump shaft.
	c) Frequency converter operation.	See section 8.1 <i>Frequency converter operation</i> .

Subject to alterations.

MTR 1S TO 20, CRK, AND SPK

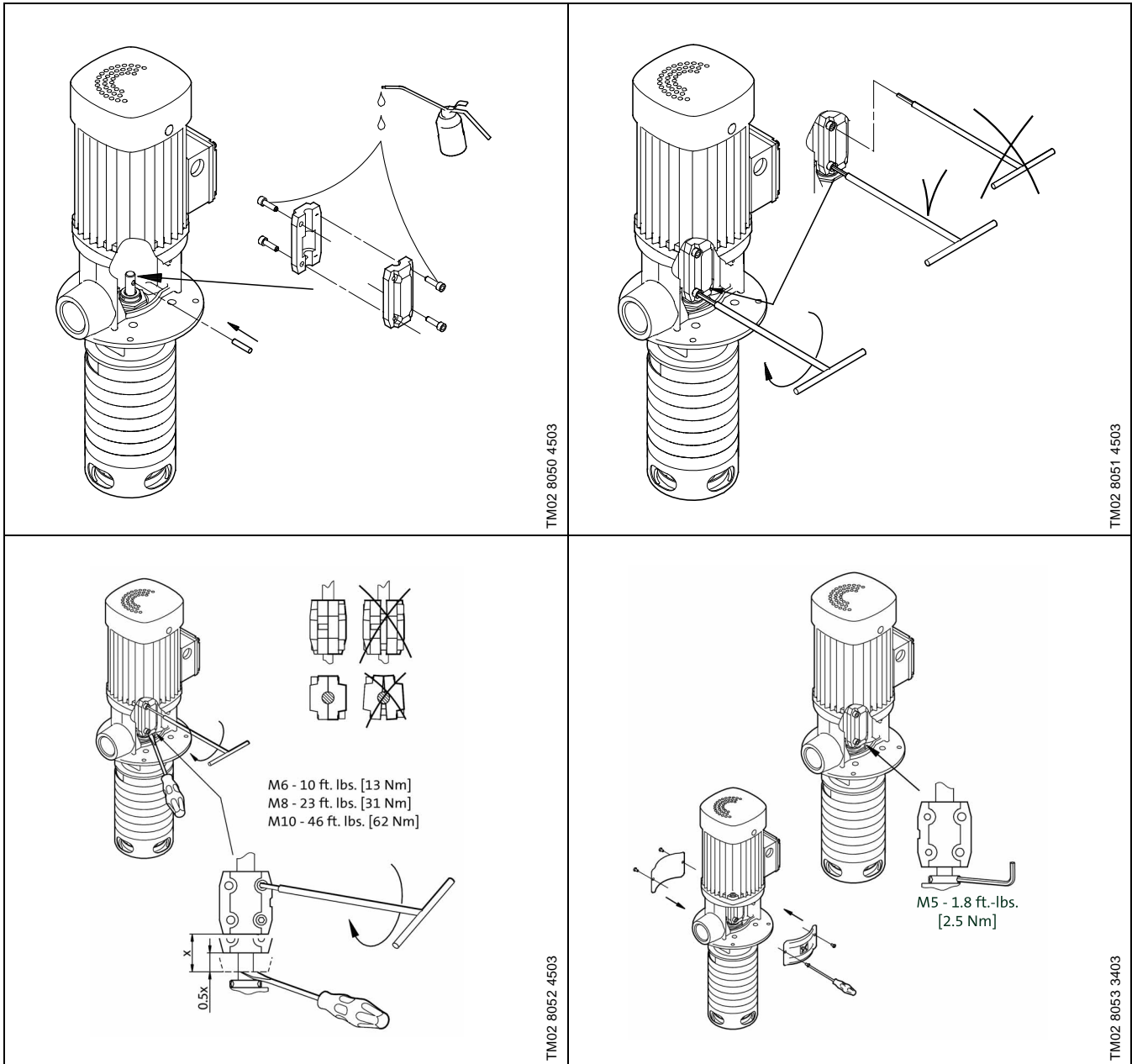
**For MTR 1s to 5, CRK, and SPK pumps:**

- Fit the shaft pin and coupling on the pump shaft. Lubricate the screws, tighten and leave loose.
- Check that the gaps on either side of the coupling halves are equal.
- Raise the pump shaft as far as possible by means of a large screwdriver or similar tool inserted underneath the coupling. Take care not to raise the motor shaft.
- **MTR 1s to 5:** Lower the shaft/coupling to half the maximum height and tighten the coupling screws diagonally while keeping the gaps between the coupling halves even.
- **CRK and SPK:** Lower the shaft/coupling 1/16" [1.7 mm] from its top position and tighten the coupling screws diagonally while keeping the gaps between the coupling halves even.

For MTR 10/15/20 pumps:

- Push the stack to the down position, tighten and torque the Shaft Seal set screws to the appropriate value specified above.
- Lift up the stack and place the Plastic Height Adjustment Tool underneath the Seal Driver.
- Tighten the Coupling Halves diagonally while keeping the gaps between Coupling Halves even. Torque to the proper value as specified in the Torque and Lubrication Instruction.

MTR 32, 45, 64

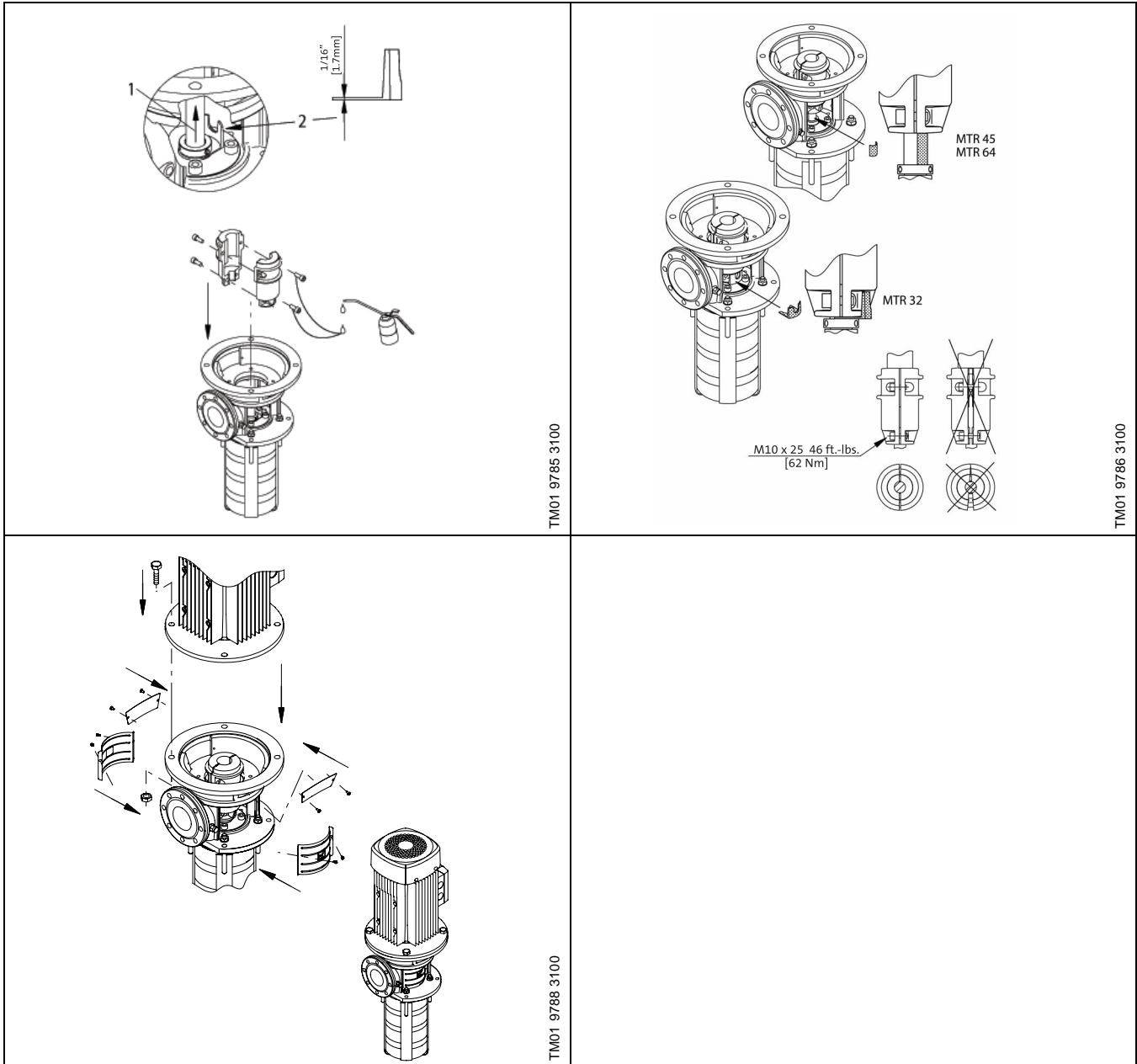

TM01 9785 3100

TM01 9786 3100

TM01 9788 3100

MTR 32, 45, and 64:

Be sure to remove the plastic height adjustment tool after tightening the coupling screws.

Be sure to tighten the coupling screws evenly so there are even gaps on either side of the coupling.

USA

GRUNDFOS Pumps Corporation
17100 West 118th Terrace
Olathe, Kansas 66061
Phone: +1-913-227-3400
Telefax: +1-913-227-3500

Canada

GRUNDFOS Canada Inc.
2941 Brighton Road
Oakville, Ontario
L6H 6C9
Phone: +1-905 829 9533
Telefax: +1-905 829 9512

México

Bombas GRUNDFOS de México S.A. de C.V.
Boulevard TLC No. 15
Parque Industrial Stiva
Aeropuerto
Apodaca, N.L.C.P. 66600
Phone: +52-81-8144 4000
Telefax: +52-81-8144 4010

L-MTR-TL-03 0612

ECM: -

The name Grundfos, the Grundfos logo, and the payoff Be-Think-Innovate are registered trademarks owned by Grundfos Management A/S or Grundfos A/S, Denmark. All rights reserved worldwide.