

The Eclipse® Series represents a dramatic advance in pump technology. Combining proven design principles with state of the art engineered composites; the Eclipse Series is the most reliable, simple and intuitive pump on the market today. Eclipse Series pumps are built for use in the harshest industrial environments. Designed to be structurally rugged with corrosion-resistant materials, the Eclipse is an ideal fit for many medium to highly corrosive liquids used in the chemical and petrochemical processing, pulp and paper and water treatment.

Key Features

- All wetted components are completely non-metallic, not lined
- Pump housings and gears are made of engineered composites, magnetically driven, and require no mechanical seals
- Zero leakage, no emissions of hazardous or regulated chemicals
- Fewer parts and material options means simplified ordering and inventory
- Front pull-out design, makes for easy service and maintenance
- Pre-defined KOPkits® allow for easy ordering and kitting of all necessary parts to bring the pump back to factory performance
- Engineered composite fluoropolymer provide superior chemical resistance
- Pump is bidirectional-can be run in either direction
- Modular design allows for the pump to be mounted in 45° increments (to a full 360°)

Control Options



MPC Vector

The MPC Vector is a microprocessor based motor speed control device, for use with all pump technologies and has been designed for simplicity, yet has many advanced features that allow a wide variety of environments and applications. This product is not just a variable speed drive. It is a state of the art multifunction controller.

Operating Benefits

- Reduced down time means less maintenance costs and more production time
- Fully encapsulated magnets allow for maximum corrosion resistance
- Close-coupled mounting eliminates the cost and potential issues associated with pump and motor alignment
- Sealless design means longer life and less maintenance
- Fewer number of parts makes it fast and easy to service
- Piping and electrical remain intact during servicing, requiring less labor



Aftermarket & Accessory Offerings

- KOPkit®
- Pressure Relief Valves
- Back Pressure Valves
- Calibration Columns
- Y-Strainers
- Gauges





Specifications and Model Selection

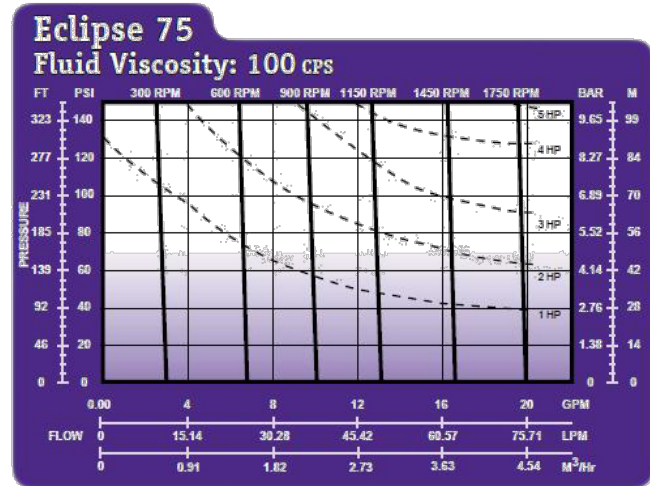
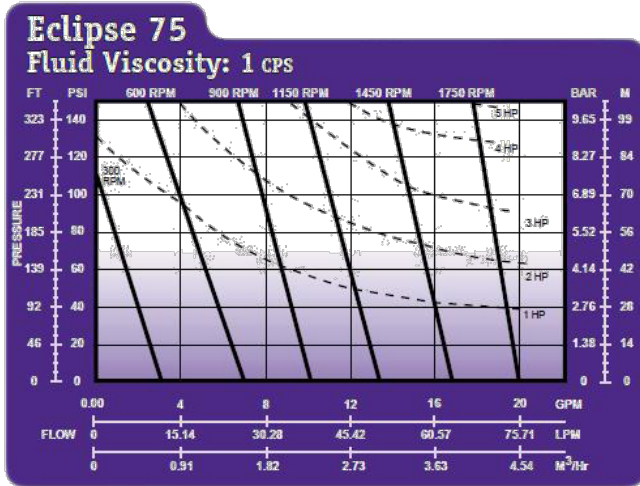

Engineering Data

Housings : Carbon-Reinforced ETFE or PVDF
 Magnet : Neodymium Encapsulated Virgin ETFE
 Gears and Liners: Carbon Reinforced PTFE
 Shafts : Alumina Ceramic
 Bearings: Carbon Graphite or Graphite-Impregnated Silicon-Carbide
 O-rings : FKM or EPDM
 Port Size and Type: 1.5 inch ANSI 150#/ DIN 32/40 Flanged
 Gear Type: External Spur Gear
 Direction of Rotation: Bi-directional
 Theoretical Displacement: 1.423 US gal/100 rev. (53.9 cc/rev.)
 Maximum Differential Pressure:

- Carbon Bearings: 100 psi (6.89 bar)
- Silicon Carbide Bearings: 150 psig (10 bar)

Maximum Allowable Working Pressure: 200 psig (14 bar)
 Maximum Speed: 1750 rpm
 Maximum Viscosity: 10,000 cps
 Maximum Fluid Temperature: 150°F (66°C), 200° F (93°C) with deration
 Minimum Fluid Temperature: -40°F (-40°C)
 Fluid pH range: 0-14
 NPSHr: 2ft (0.6m) at 1750 RPM
 Motor Frame Sizes- NEMA: 56C, 143/145TC and 182/184TC
 IEC: 100/112 B14 Face

Custom Engineered Designs

- Chemical Feed Systems
- Alternative O-Rings
- Gear Reducers
- Consult Factory for Alternate Motors

Dimensions

Inches
Mm

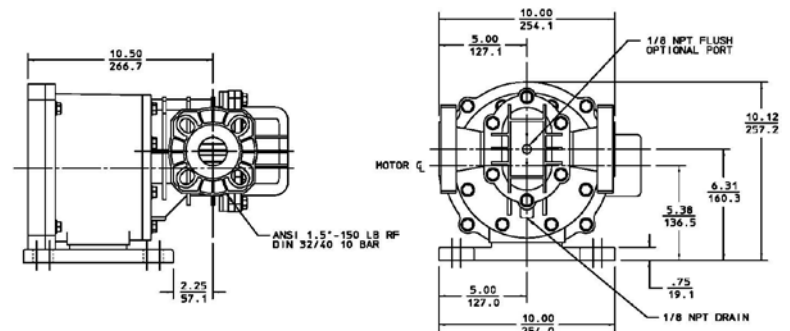

pulsafeeder.com



2883 Brighton Henrietta Townline Road
 Rochester, NY 14623
 Phone: ++1 (585) 292-8000
 Fax: ++1 (585) 424-5619

An ISO 9001 and ISO 14001 Certified Company



ECL752 - K11