



DIN STANDARD HORIZONTAL

END SUCTION CENTRIFUGAL PUMP SERIES



Installation, Operation and Maintenance Manual

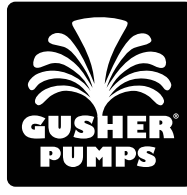

Operating and Service Manual for
DIN END SUCTION CENTRIFUGAL PUMP SERIES

FOREWORD	3
GENERAL INFORMATION	4
RECEIVING AND INSPECTION	5
INSTALLATION	6-7
OPERATION	8-9
DRAWINGS	
DIN 1 POWER FRAME	10
DIN 2 -3 POWER FRAME.....	11
PACKING SEAL.....	12
CARTRIDGE SEAL.....	12
CLOSED COUPLED STYLE	13
CDM STYLE.....	13
MALFUNCTIONS / CAUSES.....	14
SPARE PARTS RECOMMENDATIONS.....	14
PUMP TIPS.....	15

This manual is for a reference guide only. Pumps are built in many variable configurations and with different options.
Please consult with the factory for more information regarding your individual product.

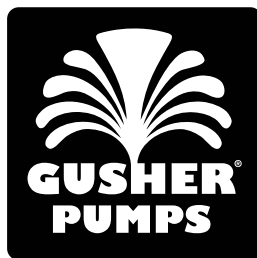

A RUTHMAN COMPANY

GUSHER®

Operating and Service Manual for DIN END SUCTION CENTRIFUGAL PUMP SERIES

The design, craftsmanship and materials used in Gusher Pumps provides for optimum performance and long, trouble-free service. As with any mechanical device, proper use and periodic maintenance will enhance the performance and life of your pump. This manual is provided as a guideline for proper installation, operation and maintenance.

THIS MANUAL MUST BE READ AND UNDERSTOOD BEFORE INSTALLING AND OPERATING ANY PUMP.

Supervision by an authorized Gusher representative is recommended to insure proper installation.



*This operating and maintenance manual contains important notices and warnings.
Please read carefully before installation, electrical connection and initiation.
Further instructions concerning the components of the pump must be observed.*

WARRANTY

Gusher Pumps, Inc. will replace or repair at our discretion, within one year of shipment from our plant, any pump in our judgement that has failed due to defects in materials or workmanship, provided the pump has been properly installed and maintained and has not been subjected to abuse. These pumps must be returned to Gusher Pumps, Inc. with complete history of service for inspection and warranty consideration. Gusher Pumps, Inc. does not accept the responsibility for transportation to and from our plant. Furthermore, we do not assume any responsibility for consequential damage or loss of production.

Warranty is only valid if genuine Gusher parts are used.

CONTACT GUSHER: 22 Ruthman Drive, Dry Ridge, Kentucky, USA 41035 PH: 859-824-5001 FAX: 859-824-3011
www.gusher.com



General Information

Heavy-Duty Casings

All sizes are self-venting with centerline discharge. All sizes have drain plugs.

Heavy-Duty Shaft-minimum deflection increases life for less maintenance.

Wear Rings

Renewable carbon wear rings.

Shaft Sleeve - Renewable Shaft Sleeve eases maintenance (easily removed) and is relieved to allow for changes in temperature.

Lubrication:

Standard pumps are with sealed for life ball bearings.

Oil Lubrication is optional

Grease Lubrication is optional

Direction of Pump Shaft Rotation:

Clockwise when viewed from coupling.

Counter clockwise when viewed from pump inlet.

Rabbeted Fits-Accurately machined rabbets ensure positive alignment, longer seal life, easy replacement of spare rotating element when maintenance is required.

Contained Casing Gasket-Protects against blow-out.

3 POWER FRAME SIZES:

MODELS WITH DIN 1 POWER FRAME

32-125	32-160	32-200	32-250
40-125	40-160	40-200	40-250
50-125	50-160	50-200	50-250
65-125	65-160	65-200	80-160

MODELS WITH DIN 2 POWER FRAME

40-315	50-315	65-250	65-315
80-200	80-250	80-215	100-160
100-200	100-250	100-315	125-200
100-250	150-200	150-250	

MODELS WITH DIN 3 POWER FRAME

80-400	100-400	125-315	125-400
150-315	150-400		

Nameplate Information

On every Gusher pump is a nameplate that provides information:

- 1) The pump's hydraulic characteristics
- 2) Pump model number
- 3) Impeller number and diameter
- 4) Serial number

Since over time, these nameplates can become damaged or removed, it is recommended that all name plate information be recorded for future reference. Having this information will insure proper spare parts or a replacement pump are supplied.

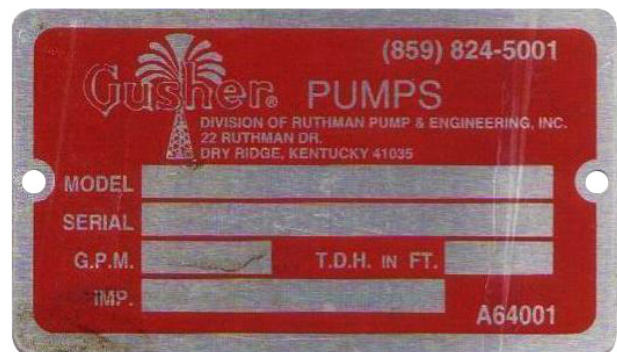

Gusher Pumps, Inc. has taken great care in preparing your pump for shipment. However, due to circumstances beyond our control, your shipment may be received damaged. Therefore we strongly recommend you take a few minutes to check your pump upon receipt. Check for cracked, bent, severely misaligned (minor misalignments almost always occur during shipment), or even missing parts. If any such damage has occurred, you must report it to the delivering carrier and Gusher Pumps, Inc. immediately.

We also recommend that you check the model number, horsepower, current characteristics, g.p.m., and ft. head of the pump received to insure that you have received the pump you ordered for your specific operating conditions. If you should find some discrepancy, report it to Gusher at once.

Storage

If your pump is not going to be installed within six months, several precautions must be taken:

1. Preservative treatment of bearings and machined surfaces is required. *(Not required for sealed for life ball bearings).*
2. Remove packing on pumps with stuffing box. The stuffing box and shaft sleeve must be oil lubricated to also protect against moisture.
3. Units equipped with mechanical seals must also be lubricated with an oil can through the NPT port while rotating the shaft by hand.

4. Pump suction and discharge points must be covered to prevent foreign material from getting into the pump and causing damage while the pump is started at a later date.
3. Pumps must be stored in a dry location.
4. Rotate pump shaft several times every other month.

Handling

! WARNING !

Pump and components are heavy. Serious physical injury or damage to equipment should occur from failure to properly lift and support pump. Steel-toed shoes must be worn at all times.

Use care when moving pumps. Lifting equipment must be able to sufficiently support the entire pump. Refer to **Figs. 2a, b, c** for proper lifting techniques.

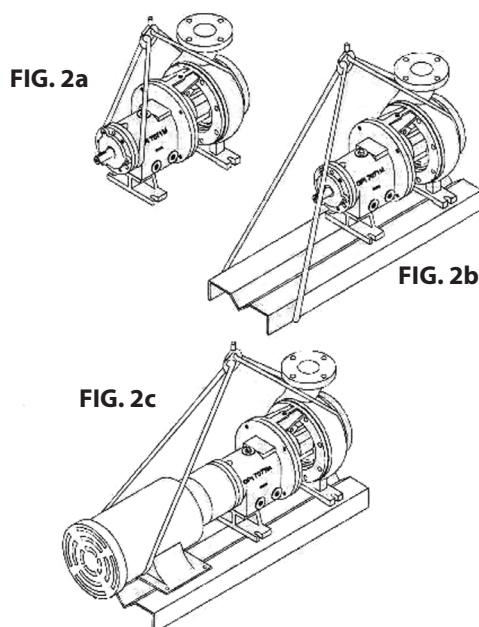

PREPARATION

When preparing your pump for installation, the discharge and suction ports must be clean and free of anything that might prohibit a tight connection. This is especially important on the suction. Air leaks can cause a pump to operate poorly or to lose prime completely.

If your pump has been taken out of storage, all the grease, oil or preservative must be removed from the ball

bearing housing. The bearing housing must then be thoroughly cleaned with kerosene or carbon tetrachloride and relubricated. *This is not required on sealed for life bearings.*

On packed pumps, it will be necessary to clean the shaft sleeve and stuffing box with kerosene or carbon tetrachloride and then repack.

LOCATION / FOUNDATION

Whenever possible, locate the pump far enough below the minimum liquid level in the reservoir so there will be a positive head on the suction at all times. Where this is not possible, the pump should be located as near to the source of supply as

possible. Allow ample room for inspection and maintenance.

The foundation should be of heavy construction to reduce vibration and must be rigid enough to resist the torque it may be subjected to.

LEVEL BASEPLATE

Customers mount the bases in a variety of ways. Grouted, welded to other steel, bolted to concrete floor, etc.

It should be noted at this time that SPECIAL CARE must be taken when leveling your pump base for coupling alignment. This is of the **utmost importance**. Once the base is in place and before securing the base, the coupling alignment should be verified.

The coupling alignment should be checked again once the base mounting is finished.

After the base is mounted, the only way to adjust the coupling alignment is by adding or removing shims underneath the motor feet.

Level baseplate to within 0.125" over the length and to within 0.062" over the width by adjusting the wedges.

COUPLING ALIGNMENT

! WARNING !

Before starting any alignment procedure, ensure that the motor power is locked out. Failure to do this will result in serious physical injury.

For trouble-free operation of this unit, proper alignment must be attained. Proper alignment is the responsibility of the installer and user of this pump.

Coupling alignment should be checked and verified:

- 1) Base installed but not secured
- 2) Base in place and secured
- 3) After connecting the system piping
- 4) Before start-up of a system

Review page 9 for coupling alignment specifications.

SYSTEM PIPING

Guidelines for piping are given in the "Hydraulic Institute Standards" available from the Hydraulic Institute, 30200 Detroit Road, Cleveland, OH 44145-1967. These guidelines should be followed to ensure proper pump operation.

! WARNING !

Never force piping into position by pulling it place with the pump suction and discharge flange bolts. This will cause misalignment between pump and driver which will adversely affect the operation of the unit, resulting in physical injury and damage to the equipment.

- 1). All piping must be supported independently of the pump.
- 2). Before connecting the piping to the pump, ensure that the base is secured.
- 3). Clean all pipe parts prior to installation.

Suction Piping

! WARNING !

NPSH_a must always exceed NPSH_r as shown on Gusher performance curves. Reference Hydraulic Institute for NPSH and pipe friction values needed to evaluate suction piping.

Properly installed suction piping is necessary for trouble-free pump operation. Flush suction piping before connection to the pump.

- 1). Never place a pipe line elbow in the horizontal plane directly at the pump suction. Use a straight pipe four to six pipe diameters long between the elbow and the pump suction.
- 2). Use suction pipe one or two sizes larger than the pump suction, with an eccentric reducer, sloping slide down, at the suction flange. Suction piping should never be smaller than the pump suction.
- 3). Never throttle the pump on the suction side. Always control flow by throttling on the discharge side of the pump.

- 4). Liquid coming back into the reservoir should not enter near the pump suction pipe and the liquid should not drop from a high level.
- 5). An isolation valve should be installed in the suction pipe at least 4 pipe diameters from the suction to allow closing of the line for pump inspection and maintenance.
- 6). Pipe should be free of air pockets.
- 7). Piping should be level or slope gradually downward from the source.
- 8). No part of the piping should extend below pump suction flange.
- 9). The size of the entrance from the supply should be one or two sizes larger than the pipe.

Discharge Piping

- 1). A gate valve and check valve should be installed in the discharge line. The check valve should be installed between the gate valve and the pump. This will allow for inspection of the check valve. The gate valve is required for priming, flow regulation and for maintenance of the pump. The check valve is required to prevent pump or seal damage from reverse flow through the pump when the motor is turned off.
- 2). If quick closing valves are installed in the system, cushioning devices should also be installed to protect the pump from surges and water hammer.
- 3). A pressure gauge should be installed in the piping just above the pump discharge. This gauge should be located at the pump discharge and before any valves, elbows or other devices.

Final Piping Check

After all piping connections have been made to the pump:

- 1) Rotate the shaft by hand to insure that there is no binding and all parts are free.
- 2) Re-check pump alignment to detect any pipe strain. If pipe strain exists, correct piping.

PREPARATION FOR START-UP

Check Rotation

- 1). Wire the motor according to motor manufacturers specifications and according to state and local regulations.
- 2). Lock out power to driver.
- 3). Disconnect motor/pump shaft coupling to prevent dry operation of the pump when checking rotation.

! WARNING !

Operating the pump dry will cause damage to the mechanical seal and may cause the rotating parts to seize.

- 4). Make sure everyone is clear. Jog the motor. Determine if the motor shaft rotation is correct. Refer to page 4 to determine proper motor shaft rotation. Correct if necessary.

Couple Pump and Motor

- 1). Lock out power to motor to prevent accidental rotation and physical injury.
- 2). Install and lubricate coupling per manufacturers instructions
- 3). Verify coupling alignment. Review page 9 for coupling alignment specifications.
- 4). Install coupling guard.

! WARNING !

Never operate a pump without the coupling guard properly installed. Personal injury can occur if pump is run without coupling guard.

INITIAL STARTING

- 1). Open all inlet piping valves 100%.
- 2). Open discharge valve 10-15%
- 3). Remove vent plug on casing to insure pump has liquid inside the casing.
- 4). Review pump nameplate and obtain the pressure the pump was rated for.
- 5). If your pump is packed, loosen packing gland screws to allow free leakage. Then tighten screws uniformly on packing gland until leakage is reduced to approximately 30 drops per minute. Never tighten packing enough to stop all leakage as a slight leakage is required to lubricate packing and prevent scoring of shaft sleeve.
- 6). Start motor and immediately observe pressure gauges. If discharge pressure is not quickly attained, stop the pump and attempt to restart. If pressure is still not obtained, turn the pump off and investigate the cause.
- 7). Open the gate valve in the discharge line gradually as the motor reaches full speed. (approximately 5 to 10 seconds). Adjust valve to obtain the pressure reading as per the pump nameplate.
- 8). Check pump for vibration levels, bearing temperature and excessive noise. If normal levels are exceeded, shut down and investigate.

OPERATION

- 1). Always vary the capacity with gate valve in the discharge line. Never restrict intake flow.
- 2). If the specific gravity of liquid being pumped is greater than originally assumed or if the rated flow is exceeded, the motor may overload.

OPERATION

- 3). Drain all liquid from inside of the pump if it will be exposed to freezing conditions while idle. The conditions could cause liquid to freeze and damage the pump. Liquid inside cooling coils, if supplied, should also be drained.
- 4). If your pump is packed, final leakage adjustment will be done with the pump in operation. Tighten screws uniformly on packing gland until leakage is reduced to approximately 30 drops per minute. Never tighten packing enough to stop all leakage...a slight leakage is required to lubricate packing and prevent scoring of shaft sleeve.
- 5). To prevent damage from cavitation or recirculation, always operate pump at or near rated conditions.

! WARNING !

DO NOT operate pump below minimum rated flows or with suction or discharge valves closed. These conditions could create an explosive hazard due to vaporization of pumpage and can quickly lead to pump failure and physical injury

FINAL ALIGNMENT

- 1). Run the unit under actual operating conditions long enough for the pump and motor to reach operating temperature.
- 2). Check alignment while unit is still hot.
- 3). Make any necessary adjustments and reinstall the coupling guards.

COUPLING ALIGNMENT PROCEDURE

Alignment Criteria

Angular Alignment

Check angular alignment with a micrometer or caliper. Measure from the outside of one flange to the outside of the other flange at intervals around the periphery of the coupling. **DO NOT** rotate the coupling. The difference between the maximum and the minimum must not exceed .010".

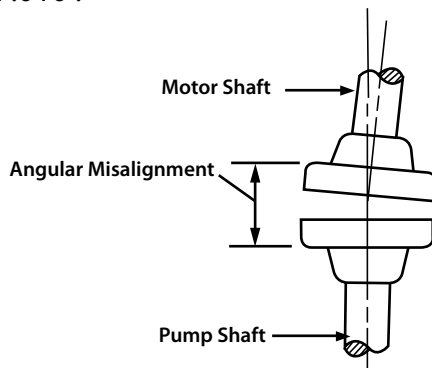

Parallel Alignment

Check parallel alignment by placing a straight edge across the two coupling flanges and measure the offset at various points around the periphery of the coupling. **DO NOT** rotate the coupling. If offset exceeds .010", realign the coupling.

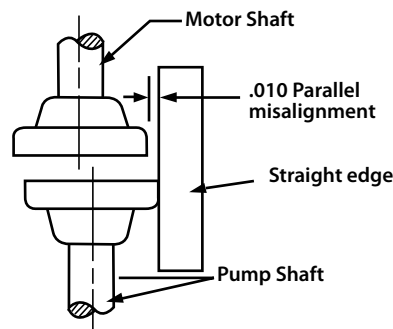

DIN 1 (SMALL) POWER FRAME

Models for DIN 1

32-125	32-160	32-200	32-250
40-125	40-160	40-200	40-250
50-125	50-160	50-200	50-250
65-125	65-160	65-200	65-250

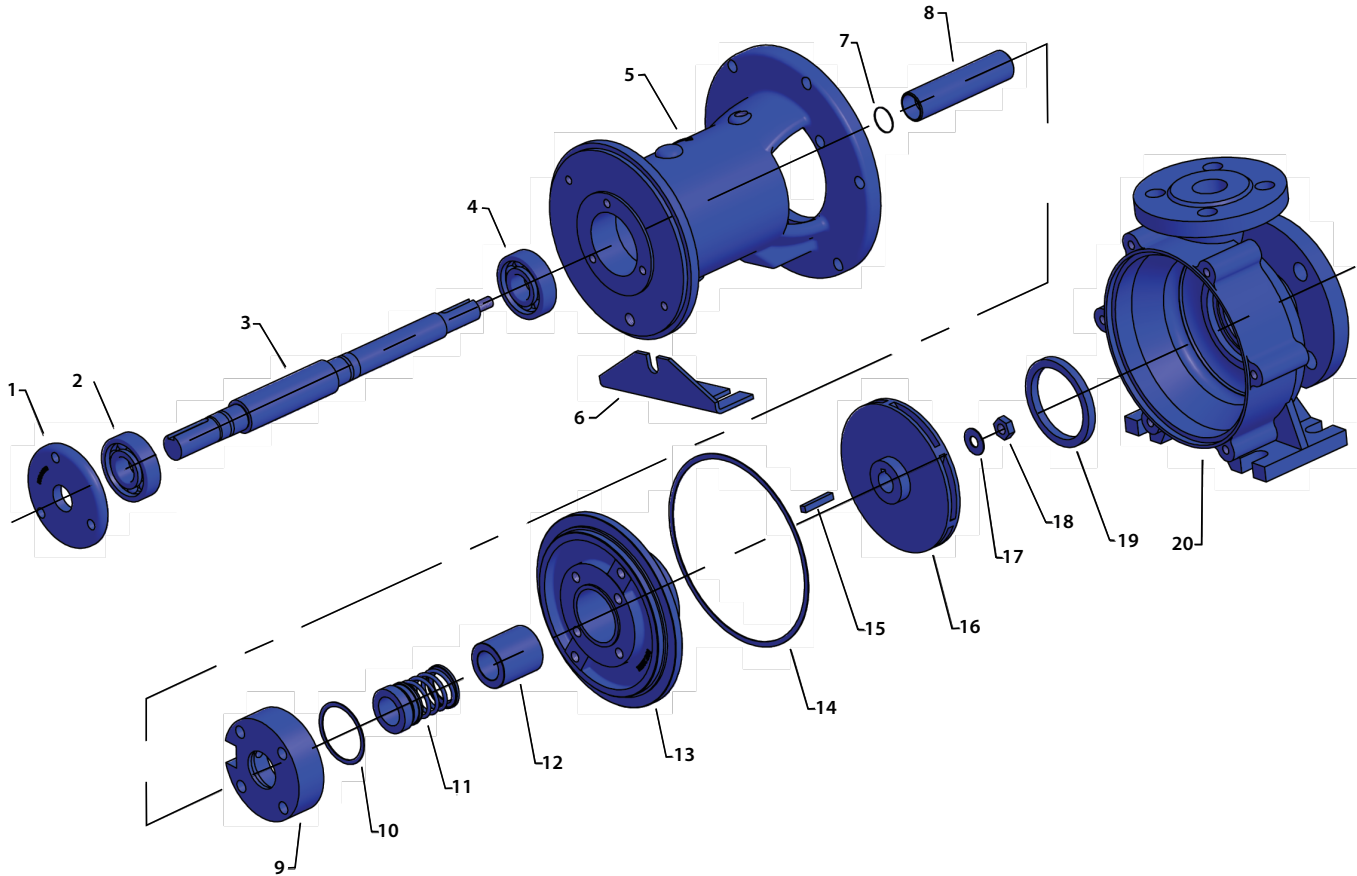

Part Number	Description	Part Number	Description
1	Bearing Retainer	10	Gasket
2	Ball Bearing	11	Mechanical Seal
3	Shaft	12	Spacer Sleeve
4	Ball Bearing	13	Stem Plate
5	Bearing Housing	14	Gasket
6	Pedestal	15	Impeller Drive Key
7	Gasket	16	Impeller
8	Shaft Sleeve	17	Washer
9	Seal Gland	18	Impeller Locking Nut
		19	Wear Ring
		20	Impeller Housing

Power Frame 2 & 3



DIN 2 & 3 (LARGE) POWER FRAME

Models for DIN 2

40-315	50-315	65-250
65-315	80-200	80-250
80-315	100-160	100-200
100-250	100-315	125-200
125-250	150-200	150-250

Models for DIN 3

80-400	100-400	125-315
125-400	150-315	150-400

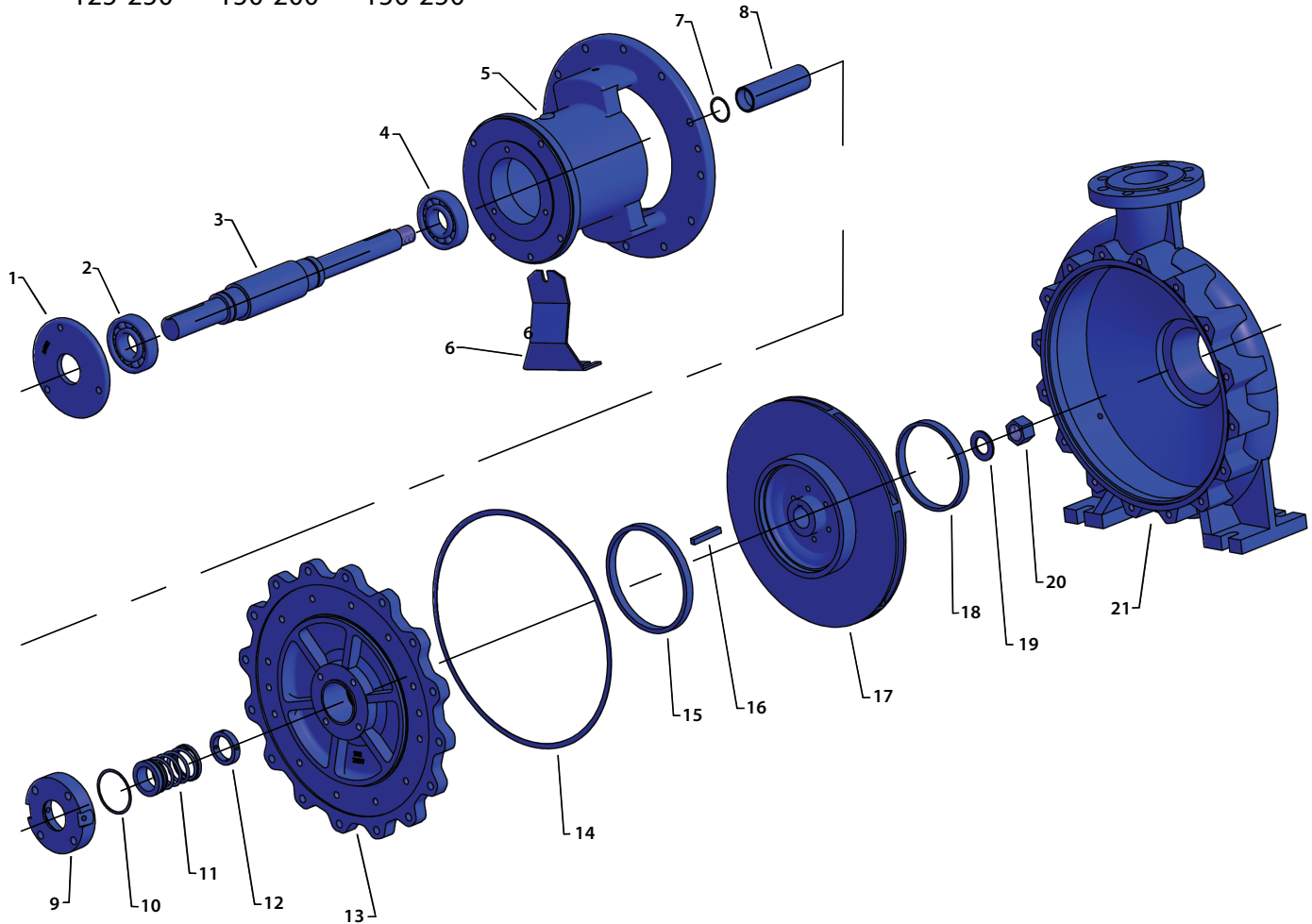

Part Number	Description	Part Number	Description
1	Bearing Retainer	10	Gasket
2	Ball Bearing	11	Mechanical Seal
3	Shaft	12	Locking Collar
4	Ball Bearing	13	Stem Plate
5	Ball Bearing Housing	14	Gasket
6	Pedestal	15	Wear Ring
7	Gasket	16	Impeller Drive Key
8	Shaft Sleeve	17	Impeller
9	Seal Gland	18	Wear Ring
		19	Washer
		20	Impeller Locking Nut
		21	Impeller Housing

CARTRIDGE MECHANICAL SEAL AND PACKING

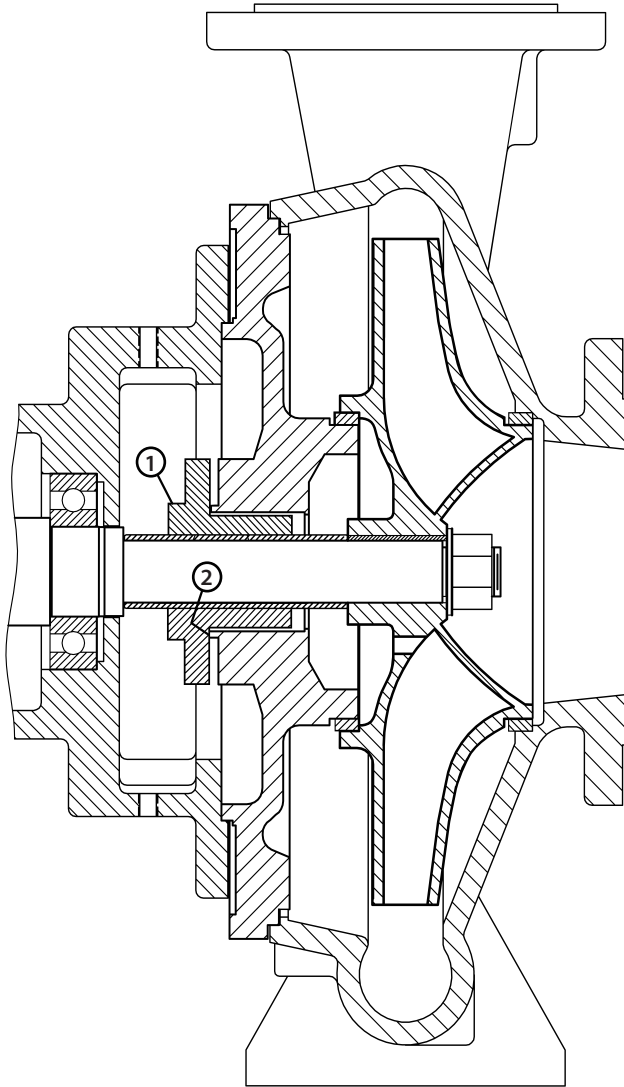

CARTRIDGE TYPE
Mechanical Seal Pump
Number Description:
1...Cartridge Seal
2...Gasket

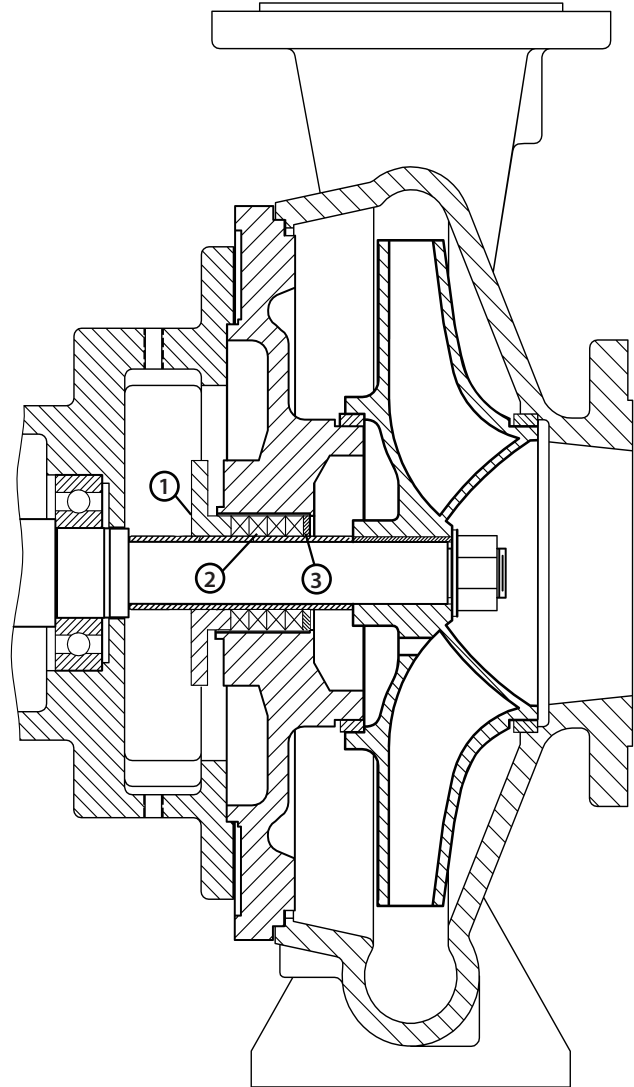

PACKING PUMP
Number Description:
1...Packing Gland
2...Packing
3...Packing Seat Washer

For all other parts descriptions, refer to pages 10 and 11

This illustration is for reference only. Your product may vary. Please consult with Gusher Pumps for any other information you may require.

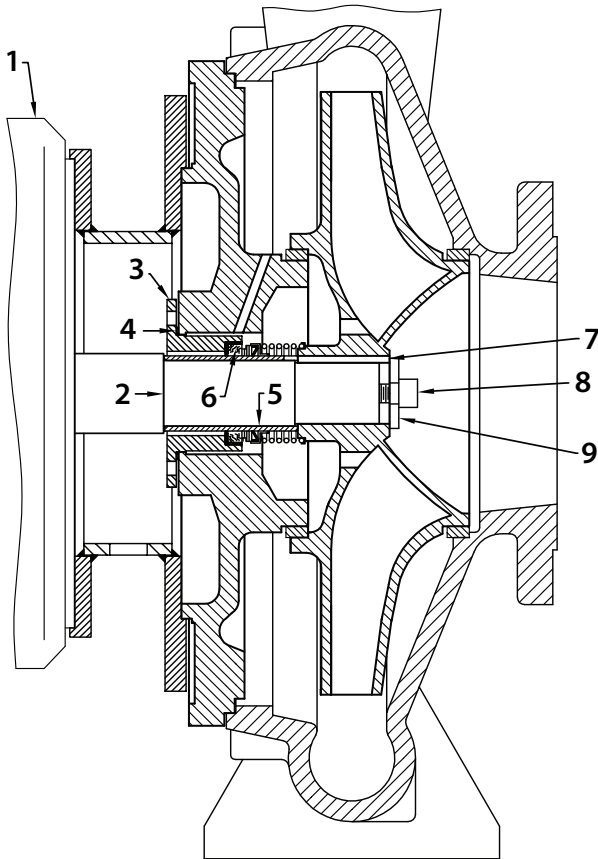

CLOSED COUPLED STYLE

Number Description:

- 1...Motor with Shaft
- 2...Gasket
- 3...Seal Gland
- 4...Gasket
- 5...Ball Bearing Housing
- 6...Mechanical Seal
- 7...Key
- 8...Bolt
- 9...Washer

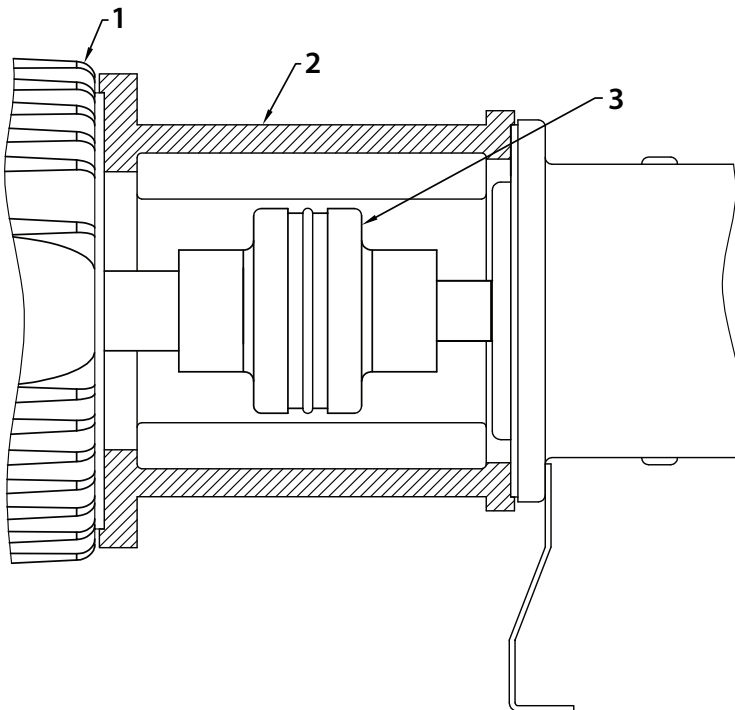

CDM STYLE

Number Description:

- 1...Motor
- 2...Barrel
- 3...Coupling

For all other parts descriptions, refer to pages 10 and 11

This illustration is for reference only. Your product may vary. Please consult with Gusher Pumps for any other information you may require.

MALFUNCTIONS / CAUSES							
Cause	Malfunction						
	No Pumping Output	Pumping Output Too Little	Pressure Build-Up Too Little	Pumping Output Stops After Start	Vibrations	Motor Becomes Hot	Cavitation (Noise Development)
Pump not filled, tubing not deaired	X						X
Speed too low	X	X	X				
Speed too high					X	X	X
Suction line leaky	X	X		X	X		X
Air or gas lock in the pumping medium			X	X	X		X
Counterpressure too high	X	X	X			X	
Suction head too high				X			
Feed pressure too low with hot pumping medium		X					
Tubing on suction side not sufficiently covered with liquid	X	X		X	X		X
Density of pumping medium too high		X	X			X	
Viscosity of pumping medium too high		X	X			X	
Impeller obstructed	X	X		X	X		X
Tubing on suction side obstructed	X	X		X			
Wrong rotation	X	X	X				
Split rings worn out		X	X				
Impeller damaged		X	X		X		X
Driving motor defective						X	
Voltage too low						X	
Frequency too low						X	
Running on 2 phases						X	
Installation / foundation unstable					X		
Motor - pump not well aligned					X	X	
Bearing worn out					X		
Balance error in the impeller					X		
Impeller too small		X	X				

SPARE PARTS

Gusher recommends that the following spare parts be kept in stock to decrease the customer's down time...

- 1). Impeller
- 2). Wear Rings
- 3). Ball Bearings
- 4). Shaft Sleeve
- 5). All necessary gaskets
- 6). Mechanical seal (if applicable)
- 7). Packing (if applicable)
- 8). Shaft
- 9). Impeller Drive Key
- 10). Impeller Retaining Washer
- 11). Impeller Retaining Nut
- 12). Coupling Insert

COUPLING GUARDS

- Never operate a pump without coupling guards properly installed.

CONNECTIONS

- Never force piping to make connection with a pump.
- Use only fasteners of proper size and material.
- Ensure there are no missing fasteners.
- Beware of corroded or loose fasteners.

LUBRICATION

- Standard pumps are with sealed for life ball bearings.
- Oil lubrication is optional.
- Grease lubrication is optional.
- If lubrication information is required, consult the factory.

OPERATION

- Never operate below minimum rated flow or either suction/discharge valves closed.
- Do not open vent or drain valves, or remove plugs while the system is pressurized.
- Pump should not be allowed to operate in a dry mode. This will cause damage to mechanical seals, packing and other pump parts.

MAINTENANCE SAFETY

- Never apply heat to remove impeller.
- Always lockout power.
- Ensure pump is isolated from the system and pressure is relieved before disassembling pump, removing plugs or disconnecting piping.
- Use proper lifting and supporting equipment to prevent serious injury.

MECHANICAL SEALS

- Must always have liquid for lubrication.
- Double type mechanical seals must have an external supply source of liquid. This external liquid must be circulated through the seal chamber at a pressure equal to or greater than the pump discharge pressure at all times.

PACKING

- Packing must be allowed to leak. This leakage is the lubrication between the packing and the shaft / sleeve.

SHAFT END PLAY

- Maximum pump shaft end play is 0.031"

STOPPING / STARTING CYCLES

- Maximum start / stop cycles per hour is 6. Consult the factory if more cycles are required

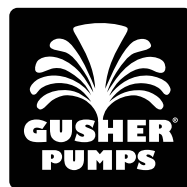

A RUTHMAN COMPANY

CONTACT GUSHER: 22 Ruthman Drive, Dry Ridge, Kentucky, USA 41035 PH: 859-824-5001 FAX: 859-824-3011
www.gusher.com



A RUTHMAN COMPANY
www.gusher.com

Gusher Pumps of Dry Ridge

22 Ruthman Drive
Dry Ridge, KY 41035
Phone: 859-824-5001
Fax: 859-824-3011
Web: www.gusher.com

Gusher Pumps of Williamstown

115 Industrial Drive
Williamstown, KY 41097
Phone: 859-824-3100
Fax: 859-824-7248
Web: www.gusher.com

Gusher Pumps of California

8226 Salt Lake Avenue
Cudahy, CA 90201
Phone: 323-773-0847
Fax: 323-773-0958
Email: gusherca@aol.com

Gusher Pumps of New Castle

403 North Ninth Street
New Castle, IN 47362
Phone: 765-529-5624
Fax: 765-521-0008
Email: gusherpump@insightbb.com

**Additional
Ruthman Company
Partners:**

BSM Pump Corp.

180 Frenchtown Road
North Kingstown, RI 02852
Phone: 401-471-6350
Fax: 401-471-6370
Web: www.bsmpump.com

Great Lakes Pump & Supply Co.

1075 Naughton
Troy, MI 48083
Phone: 248-528-9100
Fax: 248-528-9015
Web: www.greatlakespump.com

Nagle Pumps

1249 Center Avenue
Chicago Heights, IL 60411
Phone: 708-754-2940
Fax: 708-754-2944
Web: www.naglepumps.com

Process Systems, Inc.

Michigan, Main Headquarters
23633 Pinewood
Warren, MI 48091
Phone: 586-757-5711
Fax: 586-758-6996
Web: www.INFO@psi4pumps.com

Ruthman... Another Word for Innovation



It began in 1912, servicing mechanical components of the steamboats on the Ohio River. The company founder, Alois Ruthman, was a man of vision and saw part of the future of the company was in the development of a reliable industrial pump.

In 1924, with the conception of the first vertical ball bearing sealless centrifugal pump, Ruthman Pump and Engineering furthered the design on a unit with a one piece motor driven shaft. The pump was called "Gusher", giving birth to the trade name Gusher Pumps, and the coining of the term "coolant pump".

Wanting to carry on the tradition of quality and reliability started by his father, Thomas R. Ruthman joined the company in 1949. In the early 1990's Thomas R. Ruthman's son, Thomas G. Ruthman joined the company, continuing this same tradition. Maintaining the reputation of Gusher Pumps by innovation and customer service, the company has grown to service companies worldwide.

**Process Systems, Inc.
Midwest Service Center**

485 N State Route 341 South
Mellott, IN 47958
Phone: 765-295-2206
Fax: 765-295-2243
Web: www.process-systems-inc.com

Superior Engineered Systems

1850 N. Carpenter Rd
Titusville, FL 32796
Phone: 321-747-0733
Fax: 321-747-0529
Web: www.superiorengineeredsystems.com

Wagner Process Equipment

3727 Metro Drive, Suite B
Stockton, CA 95215
Phone: 209-931-0100...510-786-3929
Fax: 209-931-7910...510-786-3722
Web: www.wagnerprocess.com

**Ruthman Companies
Worldwide:**

Ruthmann Pumpen

Northberger Strabe 60
Eschweiler Germany D-52249
Phone: +49 (0) 2403 5595 0
Fax: +49 (0) 2403 5595 20
Web: www.ruthmannpumpen.de

**Birmingham Pump Supply Co.
Incorporating Beresford Pumps**

Unit 7 Network Park
Duddeston Mill Road
Saltley, Birmingham England B81AU
Phone: +44 (0) 121 503 3000
Fax: +44 (0) 121 503 3002
Web: www.birminghampumps.co.uk

Gusher Pumps, Shanghai

ROOM 4012,
Polar Star Business Plaza
No. 913 Changlin Road,
Shanghai, China 200443
Phone: 86-021-26616611
FAX: 86-021-26328038
上海市长临路913号 北斗星广场 4012
室 邮编:200443
电话: 86-021-26616611
传真: 86-021-26328038
Email: djenkins@gusher.com
China Mobile: 13402145203
USA Mobile: 513-607-4449



**Ruthman Companies
Corporate Headquarters**

1212 Streng Street, Cincinnati, OH 45223
Phone: 513-559-1900 **Fax:** 513-559-0035



ruthmancompanies.com