

TYPE VL/VLS
VERTICAL INLINE PUMPS
Close or Split Coupled



EXPERIENCE WHERE IT COUNTS

Nothing speaks volumes more than the expertise of a company and their ability to continually provide high-quality, reliable products. With more than 60 years of experience in the design, manufacture, and application of pumps and pumping systems, you can rest assured that a Grundfos pump is a sound investment.

Grundfos is a pioneer of innovative pumping solutions and dedicated to developing, producing, and selling the highest quality pumps and pumping systems while at the same time contributing to a better quality of life and a healthier environment.

With a focus on reliability, premium quality, high efficiency, low life-cycle costs, and sustainability, Grundfos has become the preferred partner and supplier for consulting engineers, municipalities, developers, and building owners.

The PACO VL/VLS series of Grundfos pumps are part of the SMART family of pump products which are better engineered to increase efficiency and reduce radial loads. SMART pumps are also designed to help reduce operating and maintenance costs.

The VL/VLS Inline pumps have proven to be extremely versatile, often exceeding the requirements for a variety of market applications, such as chilled water, condenser water, and hot water systems.

WHAT'S YOUR INSTALLATION FOOTPRINT?

When floor space is a consideration, you'll want to go with the VL. Where many other pumps might not fit, the VL's vertical inline mounting guarantees the smallest footprint, literally requiring no floor space.



INNOVATIVE DESIGN FOR OPTIMUM OPERATION

Grundfos pushes the limits of pump performance. The VL offers comprehensive sizes and configurations to meet your needs. It has a superior hydraulic and mechanical design, which produces higher efficiency, reduced pump noise, and longer pump life.

The VL can be fitted with a speed-control system, which significantly cuts energy use and provides a pump payback in as little as one to two years. Now that's a benefit you can take to the bank!

THE DOUBLE VOLUTE DESIGN DECIPHERED

The compensated double volute is another design feature that differentiates a Grundfos pump from the rest of the pack. The double volute design virtually eliminates radial forces caused by a hydraulic imbalance inherent in pump volutes.

Here's what's happening: the double volute creates a secondary cutwater 180 degrees offset from the volute cutwater that is formed where the discharge and impeller meet. This creates equal forces acting upon the impeller. Another outcome is extended seal and bearing life, which minimizes vibration and noise.

The double volute design improves efficiencies by providing two individual passageways to guide flow in the casing, creating a more stable flow and a broadband efficiency range. The broadband efficiency keeps efficiency losses to a minimum as flows move away from the best efficiency point (BEP).

One other feature of the volutes is a back pull-out design, which allows for easy removal of the pumps rotating assembly without disturbing the piping connections.

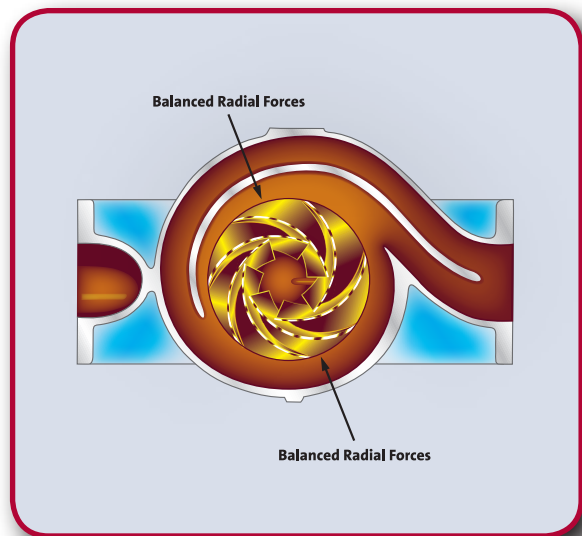
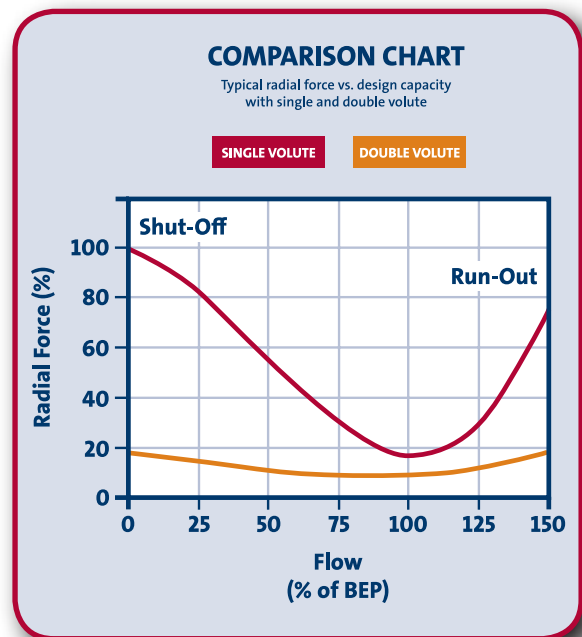

Double volute design with opposing radial forces

FEATURES WITH BENEFITS

BRACKETS

- The heavy duty cast and machined motor bracket provide the motor with a rigid and reliable mounting surface
- Accurately machined register fit of brackets allows for concentricity and near perfect alignment of rating parts

CASE WEAR RINGS

- Replaceable case wear rings protect the pump casing from wear and tear and permit simple and easy maintenance of proper running clearances
- Case wear rings reduce maintenance costs and help maintain high operating efficiencies

INLINE FLANGES

- Inline design allows for space savings, being mounted “in-the-line” requiring no floor space
- Inline design reduces initial cost by saving in material and installation costs with bases and mounting foundations
- Flanges are sized with the same suction and discharge sizes according to flow rate to most engineered pipe sizing, thus eliminating the need for reducers, elbows, or other fittings



IMPELLERS

- Engineered “closed” (double shrouded) impellers with Francis Vane design improves the pump’s efficiency
- Extended vanes and enlarged eye contribute to a reduction in vibration and noise as well as reduced overall NPSH required for these pumps
- Impellers are statically and dynamically balanced to ISO 1940-G3, decreasing noise and vibration
- Hydraulically balanced impellers reduce radial loads, prolonging seal and bearing life
- Multiple material selections allow for customized solutions to meet specific application requirements

SHAFT and SHAFT SLEEVES

- Vertical configuration of the shaft eliminates shaft slope and related distortions, promoting longer seal and bearing life compared to conventional horizontally mounted units
- Shaft sleeves are available in a wide variety of metallurgies, such as steel, bronze, etc.
- Sleeve protects the shaft from corrosion and wear, extending the overall life of the shaft and usable life of the pump

SUCTION BAFFLE

- Integrally cast suction baffle directs flow directly into the eye of the impeller for a more even distribution flow, eliminating pre-rotation and suction losses and creating a smooth, quiet pump operation

VOLUTE

- Compensated double volute design virtually eliminates radial forces caused by a hydraulic imbalance inherent in pump volutes
- Double volute design extends seal and bearing life, minimizing noise and vibration, and improving operating efficiency

QUIETER OPERATION. HIGHER EFFICIENCY.

Minimum pump noise is a necessity in most applications. Construction costs for modern commercial buildings have led to a closer proximity of work areas to mechanical rooms.

Because fluid- or structure-borne noise problems are difficult and costly to solve, equipment that runs quietly has become essential in nearly every application.

To ensure building owners the least possible noise is generated by their pumps, maximum sound levels should clearly be specified in the same manner as capacity, head, and efficiency requirements.

The chart below illustrates sound level requirements and test procedures performed in accordance with the Hydraulic Institute's standards for measuring sound produced by conventional pumping equipment.

A SMART PUMP

The VL Vertical Inline pump falls into the SMART family of products with superior hydraulic and mechanical design that produces higher operating efficiency, reliability, and reduced pump noise.

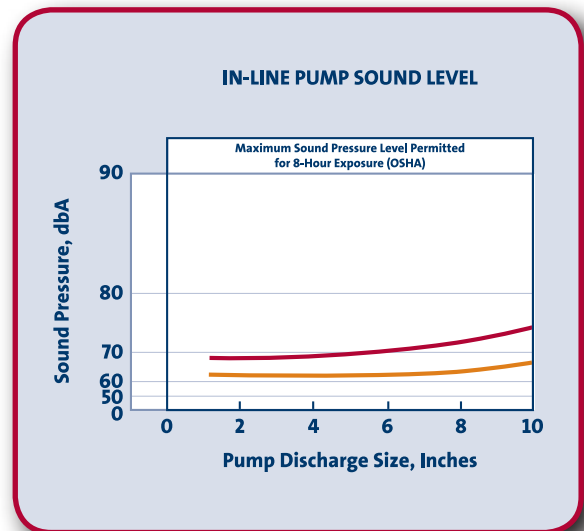



INSTALLATION FLEXIBILITY OFFERS SUPERIOR ADVANTAGES

- Saves floor space and reduces piping
- No flexible connectors or foundation grouting
- Mounts like a valve for quick installation
- No coupling alignment or bearing frame assembly
- Equal size suction and discharge pipes
- Easier to maintain and smaller spare parts inventory

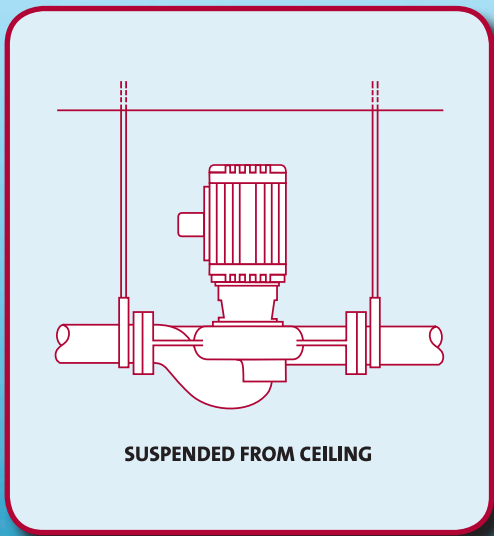

Vented Mechanical Seals

Back Pullout Design

Close Coupled Design

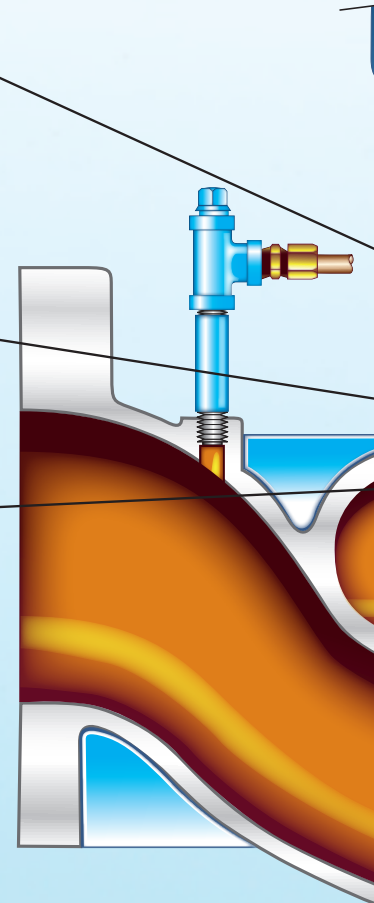

FLOOR MOUNTED

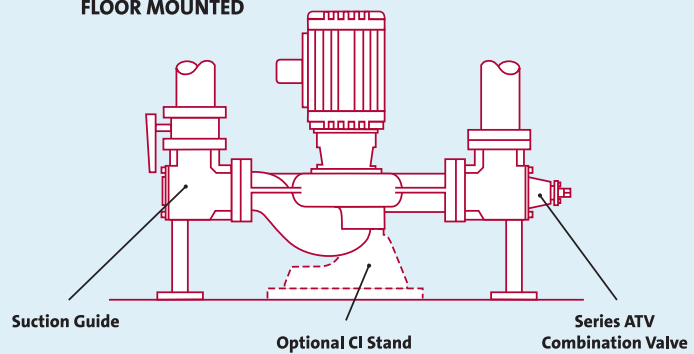

PACO VL Vertical In-Line Centrifugal Pumps – the Inner Workings

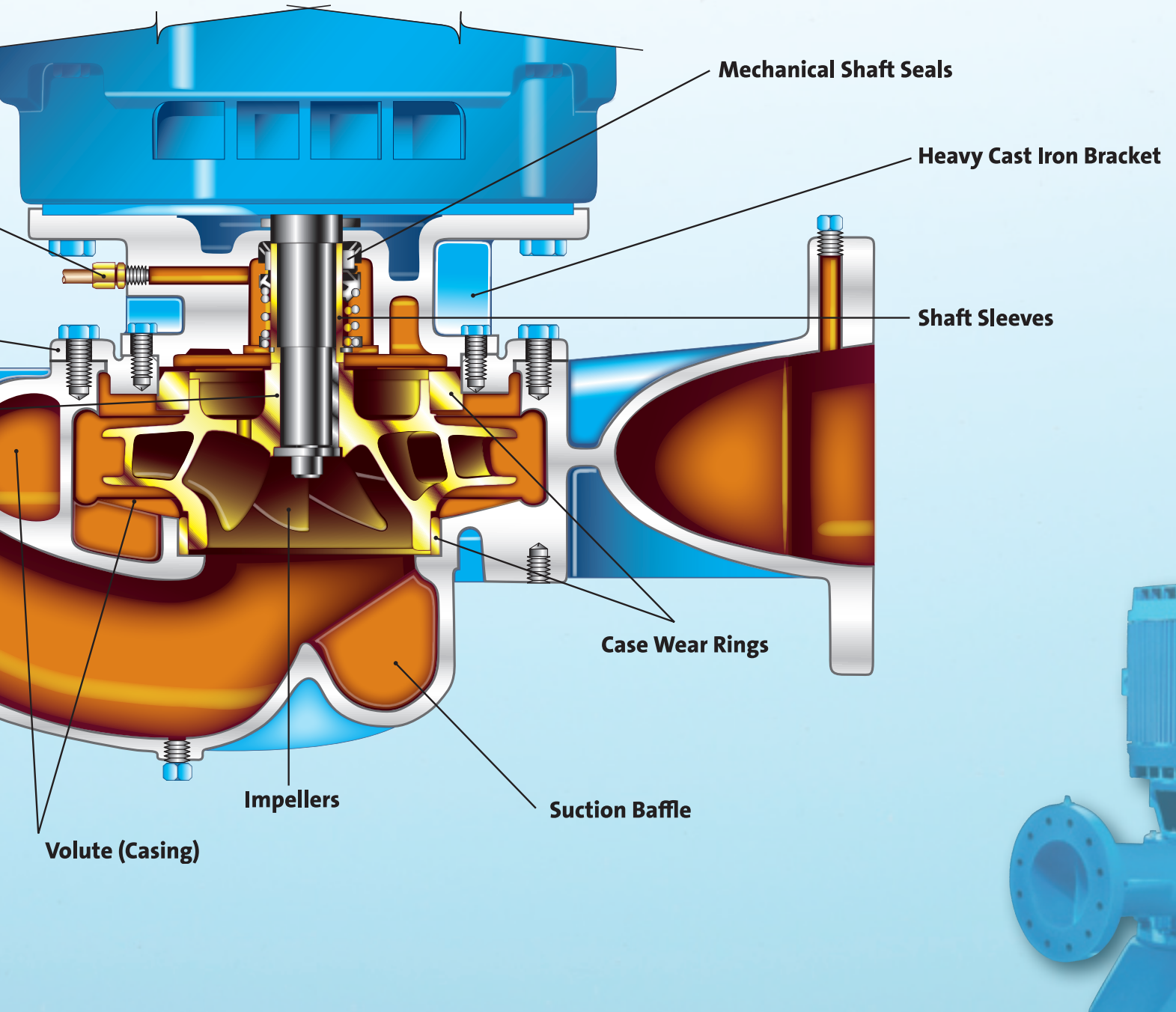



VL/VLS

Vertical Inline Pumps

Technical Data

Flow, Q:	10 to 4,000 gpm
Head, H:	10 to 420 feet
Fluid temperature:	-20° to 275° F
Working pressure:	max 300 psi
HP range:	½ to 125
Discharge sizes:	1.25" to 10"
Impellers:	7" to 15"

Applications

- Chilled water
- Condensed water
- Hot water
- Service water
- District cooling/heating systems
- Boiler/hydronic heating
- Air conditioning
- Cooling towers

Markets

- HVAC
- Recreation
- Plumbing
- Aquaculture
- General Industry/Power Plants
- Wastewater

Standard Features

- Short shaft design
- Same-size suction/discharge connections
- Compensated dual volute design (3" and larger)
- Back pull out
- Small installation footprint
- Low/reduced noise

Optional Features

- Various materials of construction
- Various seal materials and configurations
- Support stand
- High pressure capabilities

Certifications

- NSF 61/50 (available upon request)

VL/VLS Configurations

<p>CASE Cast Iron</p> <ul style="list-style-type: none"> • Ductile Iron • Bronze • Stainless Steel <p>STANDARD</p>	<p>IMPELLER Si Bronze</p> <ul style="list-style-type: none"> • Bronze, Specialty • Cast Iron • Stainless Steel 	<p>SHAFT Steel</p> <ul style="list-style-type: none"> • Stainless Steel 	<p>SLEEVE Bronze</p> <ul style="list-style-type: none"> • SS (300 series) • SS (400 series) • Ceramic Coated • Monel 	<p>Seals Type 21</p> <ul style="list-style-type: none"> • Type 1 • Type 1B • Type 8B • Packing
--	--	---	---	---

VL/VLS Performance Range

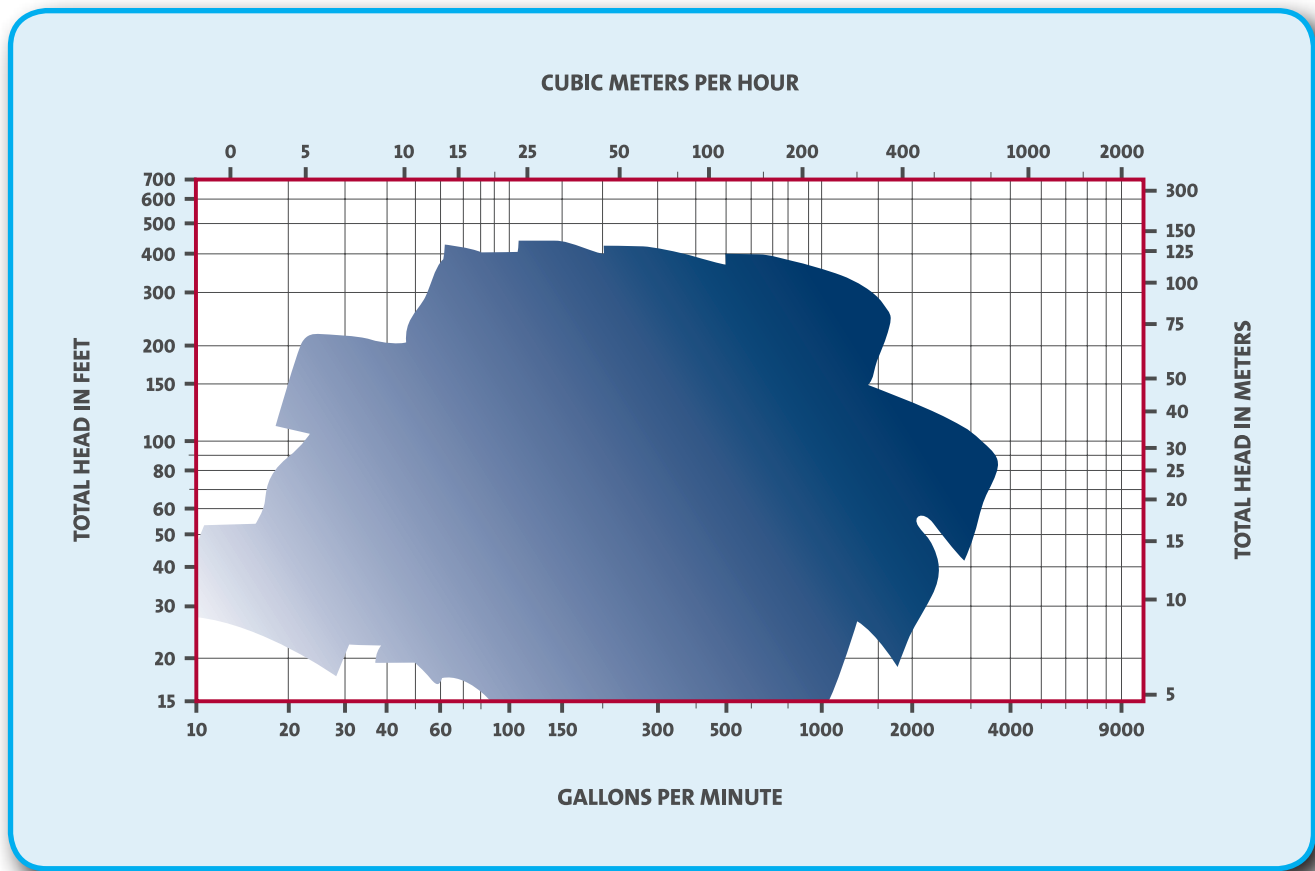

WE'VE GOT YOU COVERED

The Grundfos product portfolio features a wide range of pump styles and configurations that are designed for stable, reliable, and efficient operation. These products maximize value while minimizing operation, maintenance, and installation costs and reducing purchase price. Take a look and see if there's not a pump that might fit any of your other application or installation needs.



Grundfos MAGNA



PACO VSM





Grundfos TPE



PACO QDSC



Grundfos BoosterpaQ®

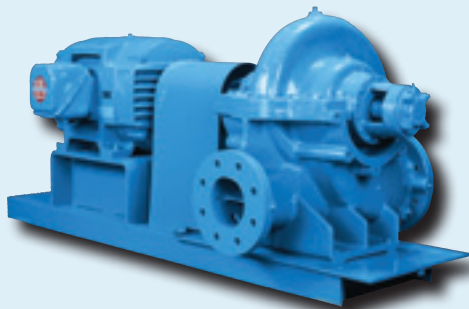

PACO KP



PACOFlo 9000



Grundfos TPE

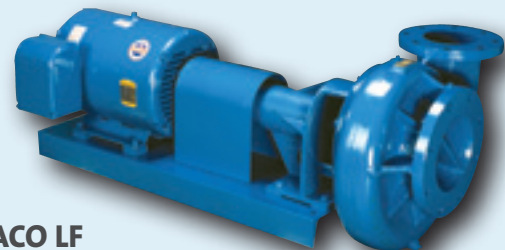

PACO LF

USA

GRUNDFOS Pumps Corporation
17100 West 118th Terrace
Olathe, Kansas 66061
Phone: (913) 227-3400
Telefax: (913) 227-3500

USA

Grundfos CBS Inc. – PACO Pumps
902 Koomey Road
Brookshire, TX 77423
Phone: (800) 955-5847
Telefax: (800) 945-4777

CANADA

GRUNDFOS Canada Inc.
2941 Brighton Road
Oakville, Ontario
L6H 6C9
Phone: (905) 829-9533
Telefax: (905) 829-9512

MEXICO

Bombas GRUNDFOS de Mexico S.A. de C.V.
Boulevard TLC No. 15
Parque Industrial Stiva Aeropuerto
C.P. 66600 Apodaca, N.L. Mexico
Phone: 011-52-81-8144 4000
Telefax: 011-52-81-8144 4010



L-PP-SL-005 • 06/09 (US)

The name Grundfos, the Grundfos logo, and the payoff Be–Think–Innovate are registered trademarks owned by Grundfos Management A/S or Grundfos A/S, Denmark. All rights reserved worldwide.

