

**VERDERHUS<sup>®</sup>**

# Screw Channel Pump

Original Operating Manual

HSB, HSL

Version 1.4v-08/2017

Print-No. 01

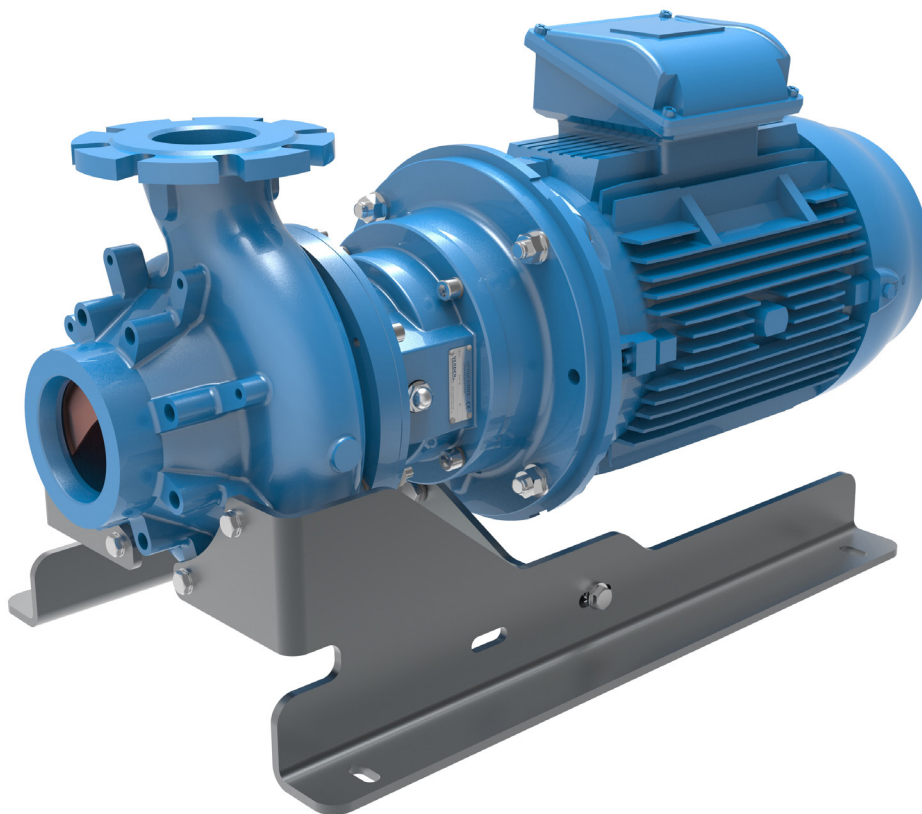

**VERDER**  
passion for pumps



Version 1.4v -08/2017  
Print-N o. 01

## Series HS 50 - 250



The information in this document is essential for the safe operation of Verderhus®. This document must be read and understood thoroughly prior to installation of pump, electrical connection and commissioning.

# Table of Contents

## 1. About this Document

- 1.1 Target Groups
- 1.2 Warnings and Symbols Used in the Manual

## 2. Safety

- 2.1 Intended Use
- 2.2 General Safety Instructions
  - 2.2.1 Product Safety
  - 2.2.2 Obligation of the Operating Company
  - 2.2.3 Obligation of Personnel
- 2.3 Specific Hazards
  - 2.3.1 Hazardous Pumped Liquids
  - 2.3.2 Sharp Edges

## 3. Transport, Storage and Disposal

- 3.1 Transport
  - 3.1.1 Unpacking and Inspection on Delivery
  - 3.1.2 Lifting
- 3.2 Treatment for Storage
- 3.3 Disposal

## 4. Layout and Function

- 4.1 Design Details
- 4.2 Labelling
  - 4.2.1 Name Plate
- 4.3 Layout
  - 4.3.1 Verderhus® Exploded View - Closed-Coupled Pump
  - 4.3.2 Verderhus® Exploded View - Long-Coupled Pump
- 4.4 Lubrication

## 5. Installation and Connection

- 5.1 Preparing for Installation
  - 5.1.1 Checking the Ambient Conditions
  - 5.1.2 Preparing the Installation Site
  - 5.1.3 Preparing the Foundation and Surface
- 5.2 Planning the Pipes
- 5.3 Electrical Connection

## 6. Commissioning and Operation

- 6.1 Shutdown and Removal/Storing the Pump Over Longer periods
- 6.2 Shutdown Without Removal Over Longer Periods (On-Site Preservation)
- 6.3 Resuming Operation

## 7. Inspection, Maintenance and Repairs

- 7.1 Inspections
- 7.2 Maintenance
  - 7.2.1 Cleaning the Pump
- 7.3 Repair
  - 7.3.1 Returning Pump to the Manufacturer
- 7.4 Ordering Spare Parts

## 8. Troubleshooting

- 8.1 Pump Malfunctions

## 9. List of Figures and Tables

- 9.1 List of Figures
- 9.2 List of Tables

## 10. Appendix

- 10.1 Technical Specifications
  - 10.1.1 Pump Range Specifications
  - 10.1.2 Ambient Conditions
  - 10.1.3 Tightening Torques
  - 10.1.4 Preservatives
  - 10.1.5 Oil and Grease

## 11. Declaration of Conformity

# 1. About this Document

Verderhus®, Series HS 50-50 to 250-250, have been developed according to the latest technology and subject to continuous quality control. These operating instructions are intended to facilitate familiarization with the pump and its designated use. This manual will act as a guide for operating the pump. You are advised to follow these guidelines to operate the pump correctly. These operating instructions do not take local regulations into account; the operator must ensure that such regulations are strictly observed by all, including the personnel responsible for installation.

## 1.1 Target Groups

Target Groups	Duty
Operating Company	<ul style="list-style-type: none"> <li>▶ Keep this manual available at the operating site of the pump.</li> <li>▶ Ensure that personnel read and follow the instructions in this manual and any other applicable documents, especially all safety instructions and warnings.</li> <li>▶ Observe any additional rules and regulations referring to the system.</li> </ul>
Qualified personnel, fitter	<ul style="list-style-type: none"> <li>▶ Read, observe and follow this manual and the other applicable documents, especially all safety instructions and warnings.</li> </ul>

Table 1 Target Groups

## 1.2 Warnings and Symbols Used in the Manual



Warning	Risk Level	Consequences of disregard
 <b>DANGER</b>	Immediate risk	Death, serious bodily harm
 <b>WARNING</b>	Potential acute risk	Death, serious bodily harm
 <b>CAUTION</b>	Potential hazardous situation	Potential damage to the pump
<b>Note</b>	For information	Possible incorrect use / maintenance of pump

Table 2 Warnings Used in the Manual



Symbol	Meaning
	Safety warning sign in accordance with DIN 4844 - W9 <ul style="list-style-type: none"> <li>▶ Take note of all information highlighted by the safety warning sign and follow the instructions to avoid injury or death.</li> </ul>
▶	Instruction
1., 2.,	Multiple-step instructions
✓	Precondition
→	Cross-reference
	Information

Table 3 Symbols Used in the Manual

## 2. Safety



The manufacturer does not accept any liability for damage resulting from disregard of this documentation.

### 2.1 Intended Use

- ▶ Only use the pump to handle compatible fluids as recommended by the manufacturer (→ 10 Appendix)
- ▶ Adhere to the operating limits
- ▶ Consult the manufacturer regarding any other use of the pump
- ▶ Pumps delivered without a motor must be fitted with a motor in accordance with the provisions of EC Machine Directive 2006/42/EC.

#### Prevention of misuse (examples)

- ▶ Note the operating limits of the pump with regard to temperature, pressure, flow rate and motor speed (→ 10.1 Technical specifications)
- ▶ Do not operate the pump with any inlet/outlet valves closed
- ▶ Only install the pump as recommended in this manual. For example, the following are not allowed:
  - Installing the pump without proper support
  - Installation in the immediate vicinity of extreme hot or cold sources (→ 10.1 Technical specifications)

## 2.2 General Safety Instructions



Observe the following instructions before carrying out any work.

### 2.2.1 Product Safety

- These operating instructions contain fundamental information which must be complied with during installation, operation and maintenance. Therefore this operating manual must be read and understood both by the installing personnel and the responsible trained personnel / operators prior to installation and commissioning, and it must always be kept easily accessible within the operating premises of the machine.  
Not only must the general safety instructions laid down in this chapter on “Safety” be complied with, but also the safety instructions outlined under specific headings.
- Operate the pump only if it and all associated systems are in good functional condition.
- Only use the pump as intended, be fully aware of safety and risk factors involved and the instructions in this manual.
- Keep this manual and all other applicable documents complete, legible and accessible to personnel at all times.
- Refrain from any procedure or action that would pose a risk to personnel or third parties.
- In the event of any safety-relevant faults, shut down the pump immediately and have the malfunction corrected by qualified personnel.
- The installation of the pump must comply with the requirements of installation given in this manual and any local, national or regional health and safety regulations.

### 2.2.2 Obligation of the Operating Company

#### Safety-conscious operation

- ▶ Ensure that the following safety aspects are observed and monitored:
  - Adherence to intended use
  - Statutory or other safety and accident-prevention regulations
  - Safety regulations governing the handling of hazardous substances if applicable
  - Applicable standards and guidelines in the country where the pump is operated
- ▶ Make personal protective equipment available appropriate to operation of the pump.

#### Qualified personnel

- ▶ Ensure that all personnel tasked with operating the pump have read and understood this manual and all other applicable documents, including the safety, maintenance and repair information, prior to use or installation of the pump.
- ▶ Organize responsibilities, areas of competence and the supervision of personnel.
- ▶ Have all work carried out by specialist technicians only.
- ▶ Ensure that trainee personnel are under the supervision of specialist technicians at all times when working with the pump.

#### Safety equipment

Provide the following safety equipment and verify its functionality:

- For hot, cold and moving parts: safety guarding should be provided by the operating company.
- For potential build up of electrostatic charge: ensure appropriate grounding if and when required.

#### Warranty



The warranty is void if the customer fails to follow any Instruction, Warning or Caution in this document. Verder has made every effort to illustrate and describe the product in this document. Such illustrations and descriptions are however, for the sole purpose of identification and do not express or imply a warranty that the products are merchantable or fit for a particular purpose, or that the products will necessarily conform to the illustration or descriptions.

Obtain the manufacturer's approval prior to carrying out any modifications, repairs or alterations during the warranty period. Only use genuine parts or parts that have been approved by the manufacturer.

For further details regarding warranty, refer to terms and conditions.

### 2.2.3 Obligation of Personnel



It is imperative that the instructions contained in this manual are complied with by the operating personnel at all times.

- ▶ Pump and associated components:
  - Do not lean or step on them or use as climbing aid
  - Do not use them to support boards, ramps or beams
  - Do not use them as a fixing point for winches or supports
  - Do not de-ice using gas burners or similar tools
- ▶ Do not remove the safety guarding for hot, cold or moving parts during operation.
- ▶ Reinstall the safety equipment on the pump as required by regulations after any repair / maintenance work on the pump.

## 2.3 Specific Hazards

### 2.3.1 Hazardous Pumped Liquids

Follow the statutory safety regulations when handling hazardous pumped liquids (e.g. hot, flammable, poisonous or potentially harmful).

Use appropriate Personal Protective Equipment when carrying out any work on the pump.

### 2.3.2 Sharp Edges

Pump parts, such as the shims and impellers, can be sharp

- Use protective gloves when carrying out any work on the pump

### 3. Transport, Storage and Disposal

#### 3.1 Transport

 Always transport the pump in a stable position and ensure that the pump is securely attached to the pallet.

##### 3.1.1 Unpacking and Inspection on Delivery

1. Report any transport damage to the manufacturer/distributor immediately.
2. Retain the pallet if any further transport is required.

##### 3.1.2 Lifting

 **DANGER**

**Death or crushing of limbs can be caused by falling loads!**

1. Use lifting gear appropriate for the total weight to be transported.
2. Make sure the pump and accessories are lifted and moved by qualified lifting personnel equipped with suitable lifting gear.
3. Do not stand under suspended loads.
4. Use a suitable lifting device to lift the pump and secure the pump as outlined in the following sketch. Take note of the centre of gravity.
5. Never use the electrical cable to lift the pump.
6. Before you lift the pump, ensure that neither the pump, the motor, nor the coupling guard can be moved on the base plate.

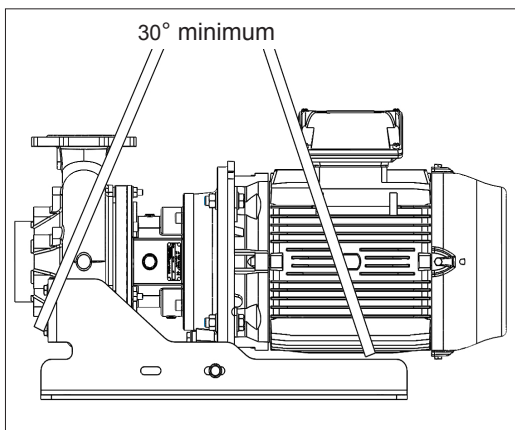

Figure 1 Lifting the Closed - Coupled Pump

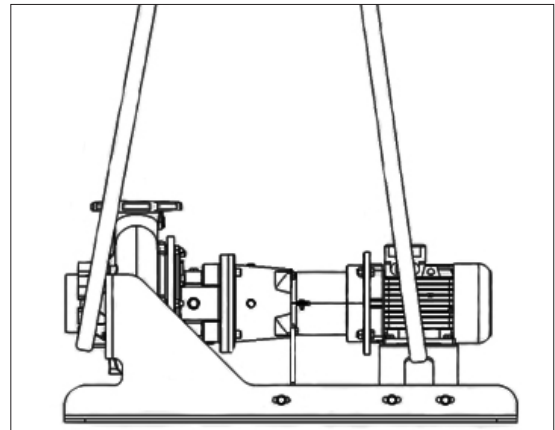



Figure 2 Lifting the Long - Coupled Pump

#### 3.2 Treatment for storage

1. Unpainted steel surfaces should be coated with rust inhibitor and the pump should be stored in a dry, dust free environment not exceeding -5 to 60°C (20 to 140°F). (→ 10.1.3 Technical specifications)
2. Close all openings with blanks, plugs or plastic covers.
3. Make sure the storage room meets the following conditions:
  - Dry, humidity not to exceed 85%, non-condensing
  - Out of direct sunlight
  - Frost-free; temperature range 0 to 60°C (30 to 140°F)
  - Vibration-free; minimize
  - Dust-free; minimize

#### 3.3 Disposal

 With prolonged use, pump parts can get contaminated by hazardous pumped liquids to such an extent that cleaning may be insufficient.

 **WARNING**

**Risk of poisoning and environmental damage by the pumped liquid or oil!**

- ▶ Use suitable personal protective equipment when carrying out any work on the pump.
- ▶ Prior to disposal of the pump:
  - Collect and dispose the lubricant in accordance with local regulations.
  - Collect and dispose of any leaking pumped liquid or oil in accordance with local regulations.
  - Neutralize residues of pumped liquid in the pump.
- ▶ Dispose of the pump and associated parts in accordance with local regulations.

## 4. Layout and Function

**i** Verderhus® screw-channel pumps can transport numerous types of slurry and sludge with minimal wear, thanks to a large, open impeller based on the working principle of a corkscrew. The suction port is a large inlet of at least 50 mm (2 in) which allows the easy passage of pulverized and intact solids. The wide flow path is unsusceptible to clogging, ragging and when pumping long fibrous fluids. The Verderhus® range of screw channel pumps is available in several different inlet sizes, ranging from 50 -250 mm (2-10 in).

### 4.1 Design Details

**i** The Verderhus® range of screw channel pump has an open channel impeller design. Because of the combination of an open channel and the centrifugal forces high flow rates and efficiencies are accomplished.

### 4.2 Labelling

#### 4.2.1 Name Plate

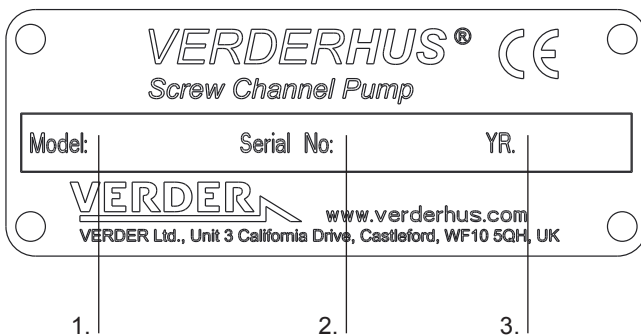

Figure 3 Name Plate

1. Pump Type
2. Serial Number
3. Year of manufacture

**i** When requesting spares, the model and serial number should always be quoted.



### 4.3 Layout

#### 4.3.1 Verderhus® Exploded View - Closed - Coupled Pump

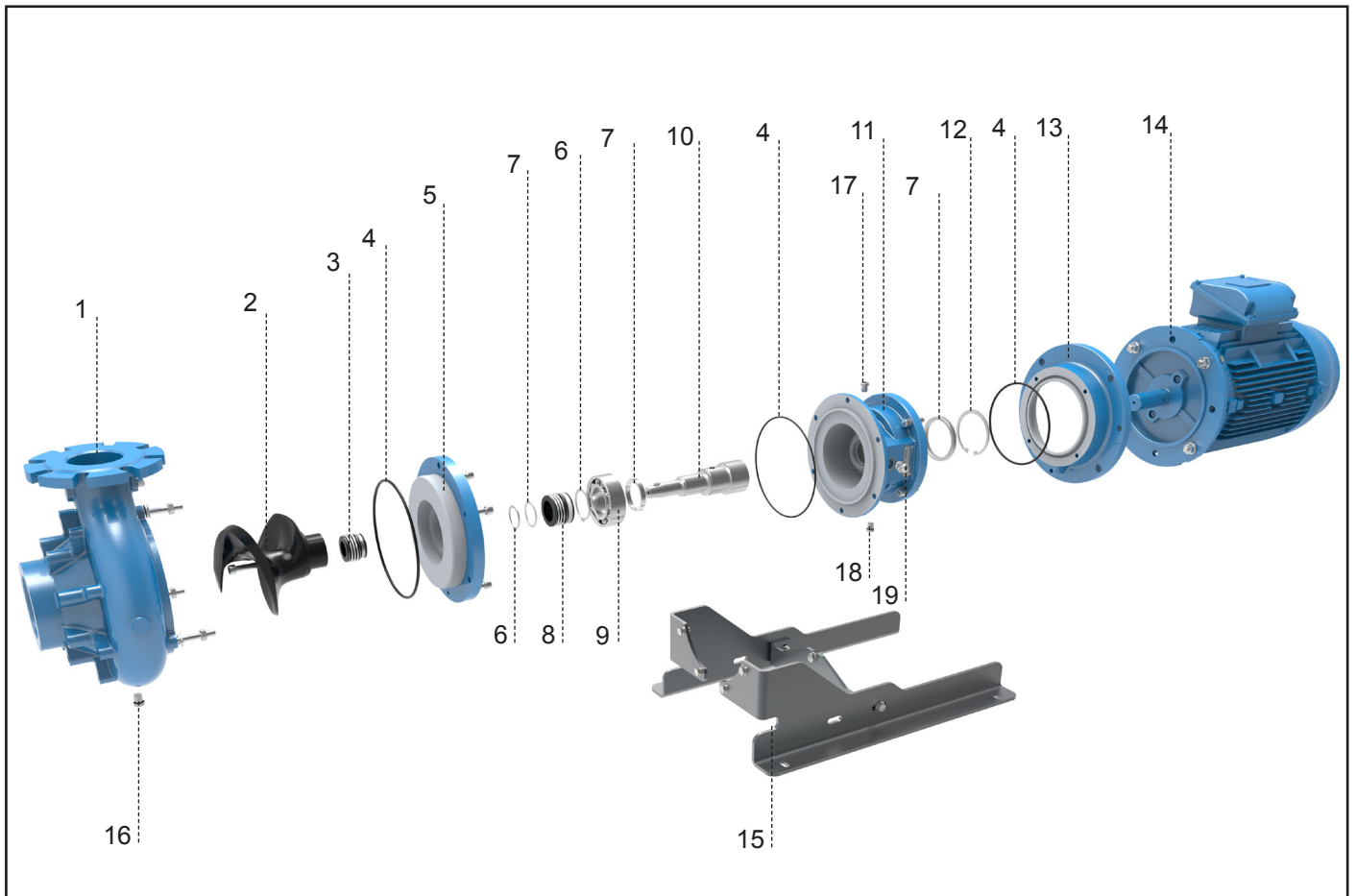

Figure 4 Verderhus® Exploded View - Closed - Coupled Pump (generic view)

1	Pump Housing	6	External Cir-Clip	11	Bearing Flange	16	Media Drain Plug
2	Impeller	7	Spacer	12	Internal Cir-Clip	17	Oil Filler Plug
3	Mechanical Seal	8	Mechanical Seal	13	Transition Flange	18	Oil Drain Plug
4	O-Ring	9	Bearing	14	Motor	19	Oil Sight Plug
5	Cooling Flange	10	Shaft	15	Base Plate		

### 4.3.2 Verderhus® Exploded View - Long - Coupled Pump

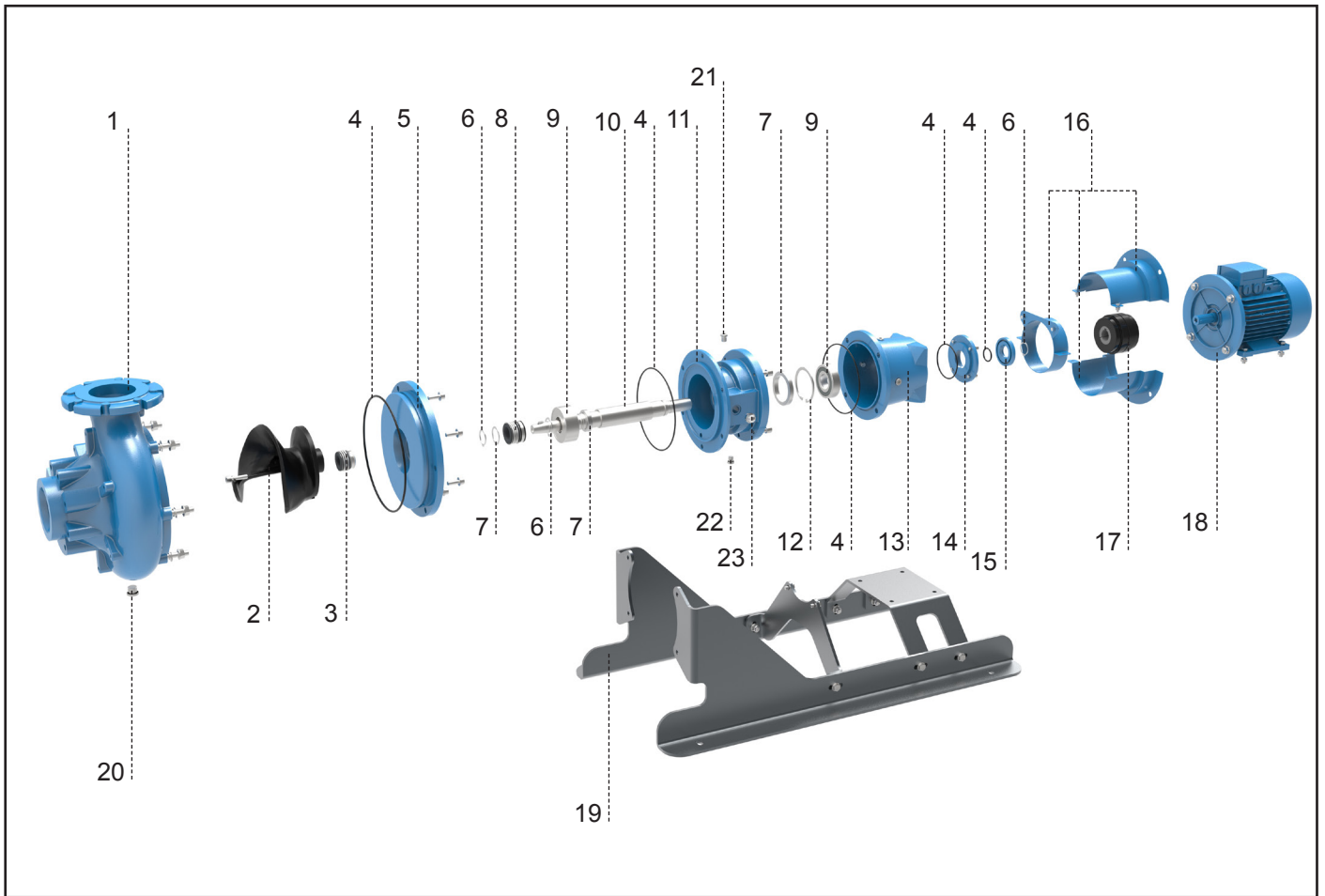

Figure 5 Verderhus® Exploded View - Long - Coupled Pump (generic view)

1	Pump Housing	7	Spacer	13	Extended Bearing Housing	19	Base Plate
2	Impeller	8	Mechanical Seal	14	Cover Plate	20	Media Drain Plug
3	Mechanical Seal	9	Bearing	15	Labyrinth Ring	21	Oil Filler Plug
4	O-Ring	10	Drive	16	Coupling Guard	22	Oil Drain Plug
5	Cooling Flange	11	Bearing Flange	17	Coupling	23	Oil Sight Plug
6	External Cir-Clip	12	Internal Cir-Clip	18	Motor		

## 4.4 Lubrication

- ▶ Bearing housing: To be filled at installation with appropriate lubricant if not supplied pre filled. (→10.1.5 Oil and Grease)

## 5. Installation and Connection

### NOTE

#### Material damage due to unauthorized modification on pump!

- ▶ Do not make any structural modifications to the pump or pump casing
- ▶ Do not carry out any welding work on the pump or pump casing

### NOTE

#### Material damage caused by ingress!

- Do not remove any protective flange covers until immediately before connecting the pipes to the pump

## 5.1 Preparing for Installation

### 5.1.1 Checking the Ambient Conditions

1. Make sure that the operating conditions are in accordance with the pump specifications
2. Make sure the required ambient conditions are fulfilled (→ 10.1.2 Ambient conditions)

### 5.1.2 Preparing the Installation Site

- ▶ Ensure the installation site meets the following conditions:
  - Pump is freely accessible
  - Sufficient space is available for the installation/removal of the pipes and for maintenance and repair work.

### 5.1.3 Preparing the Foundation and Surface

- ▶ Make sure the foundation and surface meet the following conditions:
  - Level
  - Clean (no oil, dust or other impurities)
  - Capable of bearing the weight of the pump and all operating forces
  - Ensure the pump is anchored securely at all required locations

## 5.2 Planning the Pipes

1. Always use pipes with a nominal diameter and pressure rating that is greater than or equal to the pump connections.
2. Pipes should be straight for at least 5 diameters to both inlet and outlet before any obstructions are mounted.
3. Include drainage taps in suction and discharge lines at the lowest point.

## 5.3 Electrical Connection



**DANGER**

#### Risk to health due to electric shock!

All electrical work must be carried out by qualified electricians.

1. Connect the motor to the rated power supply. Ensure the correct gland is used and that the earth connection is made and secured.
2. Make sure the motor's direction of rotation is correct.

## 6. Commissioning and Operation

### NOTE

Start-up is not permitted until such time as the pump and all associated and connected devices have been installed and checked, and the safety officer has given the go-ahead for operation to commence.



### DANGER

#### Pumped Medium

The pump may only be operated using the medium specified in the data sheet. The materials used to build the pump are compatible with this medium.

1. Remove transit filler plug and fit breather plug (→ Figure 6, item 1).
2. Ensure the staff operating the pump are familiar with the user manual.
3. The seal face lubricant for cooling both seals is filled to the mark on the indicator glass.
4. Any cooling circuit is connected and works correctly.  
Open the valves on the suction and discharge side and ensure the pump is flooded.

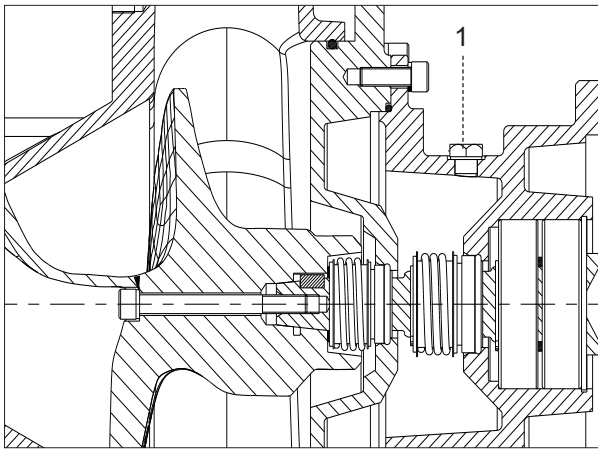

Figure 6 Checking the Lubricant Level

### 6.1 Shutdown and Removal / Storing the Pump over Longer Periods

1. The parts that come into contact with the pumped medium are to be cleaned and neutralised if necessary.
2. Refer to the storage conditions. (→ 3.2 Treatment for storage)

### 6.2 Shutdown Without Removal Over Longer Periods (On-Site Preservation)

1. Rinse, and neutralise if necessary, the pump section between the valves.
2. The pump's lowest point has a plug for releasing the medium. Remove the plug to drain the medium. (→ Figure 4, item 16), (→ Figure 5, item 20)

## 7. Inspection, Maintenance and Repairs

### DANGER

#### Risk of injury due to running pump!

- ▶ Do not carry out any repair/maintenance work on a pump whilst running.
- ▶ Follow the safety procedures for handling the product being pumped.
- ▶ Decontaminate before handling as per local safety regulations.
- ▶ Appropriate measures must be taken to relieve any pressure build up.

### DANGER

#### Risk of electrocution!

- ▶ Have all electrical work carried out only by qualified electricians.

### 7.1 Inspections



The inspection intervals depend on the pump operating cycle.

1. Check at appropriate intervals:
  - No changes in operating conditions
2. For trouble-free operation, always ensure the following:
  - No leaks
  - No unusual running noises or vibrations
  - Lubricant level (→ Figure 4 Checking the Lubricant Level)
  - Temperature is stable

### 7.2 Maintenance



VERDER LTD offers customers a service contract, which covers maintenance and repairs to the pump. Contact Customer Service, to request a non-binding offer.

#### 7.2.1 Cleaning the Pump

Make sure that no cleaning agent contaminates the pump bearings and motor.

- ▶ Cover all parts that should not come into contact with cleaning agent.
- ▶ Never spray cold liquids such as water on hot pump parts. The casing may crack if it cools too quickly, and may render the pump unusable.

### NOTE

Contact VERDER LTD. before you use a liquid cleaning agent, and confirm that the product that you intend to use is safe. The operator must ensure that the product is safe to use with the pumped medium.

- ▶ Select a suitable method for cleaning the electrical material, and consult a qualified electrician.

### 7.3 Repair

### DANGER

#### Risk of death due to electric shock!

- ▶ Have all electrical work carried out by qualified electrician only.

### WARNING

#### Risk of injury due to heavy components!

- ▶ Pay attention to the component weight. Lift and transport heavy components using suitable lifting gear.
- ▶ Set down components safely and secure them against overturning or rolling away.

#### 7.3.1 Returning the Pump to the Manufacturer

#### Obtain prior authorization before repair or return of the pump.

- ▶ Enclose a completed document of compliance when returning pumps or components to the manufacturer.

### 7.4 Ordering Spare Parts



For trouble-free replacement in the event of faults, we recommend keeping spare parts available on site.

- ▶ The following information is mandatory when ordering spare parts (→ Name plate):
  - Pump model
  - Year of manufacture
  - Part number / Description of part required
  - Serial number
  - Quantity

## 8. Troubleshooting

### 8.1 Pump malfunctions

If malfunctions occur which are not specified in the following table or cannot be traced back to the specified causes, please consult the manufacturer.

Possible malfunctions are identified and respective cause and remedy are listed in the table.

Malfunction								Potential Cause	Recommended Solution <sup>1)</sup>
No flow	Motor overloaded	Low flow	Low discharge pressure	Vibration level high	Overheating	Iregular pressure	Oil chamber overflows		
X	-	X	X	-	-	-	-	closed inlet	<ul style="list-style-type: none"> <li>▶ check suction valve setting</li> <li>▶ check for blockages</li> <li>▶ DO NOT RUN IN THIS CONDITION</li> </ul>
X	-	-	-	-	-	-	-	closed discharge	<ul style="list-style-type: none"> <li>▶ check discharge valve setting</li> <li>▶ DO NOT RUN IN THIS CONDITION</li> </ul>
X	-	-	-	-	-	-	-	motor not running	▶ check wiring
-	-	X	X	-	-	-	-	motor direction	▶ check wire connections are correct
-	-	X	X	-	-	-	-	NPSH exceeded	▶ check suction conditions including pipe work and any associated equipment
-	-	X	-	-	X	-	-	low suction head	▶ check pressures and adjust as required
-	-	X	-	-	X	-	-	high discharge head	▶ check pressures and adjust as required
-	-	X	-	-	X	-	-	low cooling oil level	▶ check oil level and address any shortage
-	-	X	-	-	X	-	-	dirt covering pump	▶ clean
-	-	-	X	-	-	-	-	discharge valve	▶ close down to reinstate pressure
-	-	X	X	X	-	-	-	cavitation	▶ increase suction head; can suction valve be opened up
-	X	-	-	X	X	-	-	duty too high	▶ reconsider impeller choice
-	X	-	-	X	X	-	-	bearing failure	▶ stop pump and repair
-	X	X	-	-	-	X	-	pumped media changed	▶ incorrectly specified impeller for media
-	-	-	-	-	X	-	-	fluid temperature too high	▶ add cooling
-	-	-	-	-	-	-	X	seal leaking	▶ stop pump and repair
-	-	-	-	X	-	-	-	impeller rubbing	▶ stop pump and repair

<sup>1)</sup> Make sure the pipe sizes are correct for the pump and installation.

Table 4 Troubleshooting



## 9. List of Figures and Tables

### 9.1 List of Figures

Figure 1	Lifting the Closed - Coupled Pump	3.1.2
Figure 2	Lifting the Long - Coupled Pump	3.1.2
Figure 3	Name Plate	4.2.1
Figure 4	Verderhus® Exploded View - Closed Coupled Pump (generic view)	4.3.1
Figure 5	Verderhus® Exploded View - Long Coupled Pump (generic view)	4.3.2
Figure 6	Checking the Lubricant Level	6

### 9.2 List of Tables

Table 1	Target Groups	1.1
Table 2	Warnings Used in the Manual	1.2
Table 3	Symbols Used in the Manual	1.2
Table 4	Troubleshooting	9
Table 5	Pump Range Specifications	10.1.1
Table 6	Pump Fastener Tightening Torques	10.1.3
Table 7	Recommended Lubricants	10.1.5
Table 8	Declaration of Conformity	11

## 10. Appendix

### 10.1 Technical Specifications

#### 10.1.1 Pump Range Specifications

Size	Value
Max. flow rate	1200 m <sup>3</sup> /h (5280 GPM)
Max. delivery pressure	55 mwc (180 ft.wc)
Temperature of pumped liquid	< 100 °C (210 °F)
Dimensions	→ refer pump datasheet

Table 5 Pump Range Specifications

#### 10.1.2 Ambient conditions

 Operation under any other ambient condition would require approval from the manufacturer

##### Operating conditions

- Ambient temperature –5 °C to +45 °C (-40 to +100 °F)
- Relative humidity (non-condensing) – long—term ≤ 85 %
- Setup height above sea level ≤ 1000 m (320 ft)

##### Storage conditions

- Ambient temperature 0 to +60°C (+30 to +140°F)
- Relative humidity (non-condensing) – long—term ≤ 85 %

#### 10.1.3 Tightening Torques

 Tightening torques should be applied at the following torque values:

Fastener Size	Torque Value (Nm)			
	Steel - 8.8	Steel - 12.9	A2 - 70 SS	A4 - 70 SS
M8	23	41	22	22
M10	45	81	43	43
M12	82	142	74	74
M16	204	350	189	189
M20	383	685	370	370

Table 6 Pump Fastener Tightening Torques

#### 10.1.4 Preservatives

 Use e.g. RUST-BAN 335 or similar preservatives on bare metal.

#### 10.1.5 Oil and Grease

 Recommended lubricants

**Bearings:** MULTIPURPOSE Grease  
**Mechanical seal:** PETROLEUM Jelly  
 Shell Omala S4 GX 150 H1  
 Mobil SHC CIBUS 150 H1  
 Renolin CLP GEAR OIL 150\*

\*Verder recommends using Renolin CLP GEAR OIL 150.

Table 7 Recommended Lubricants



