

DEAN PUMP® SERIES R4000

Horizontal Process Pumps

DATA PAK

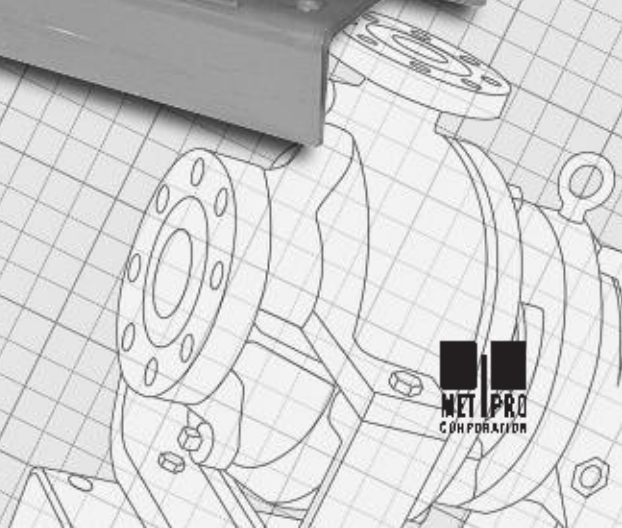
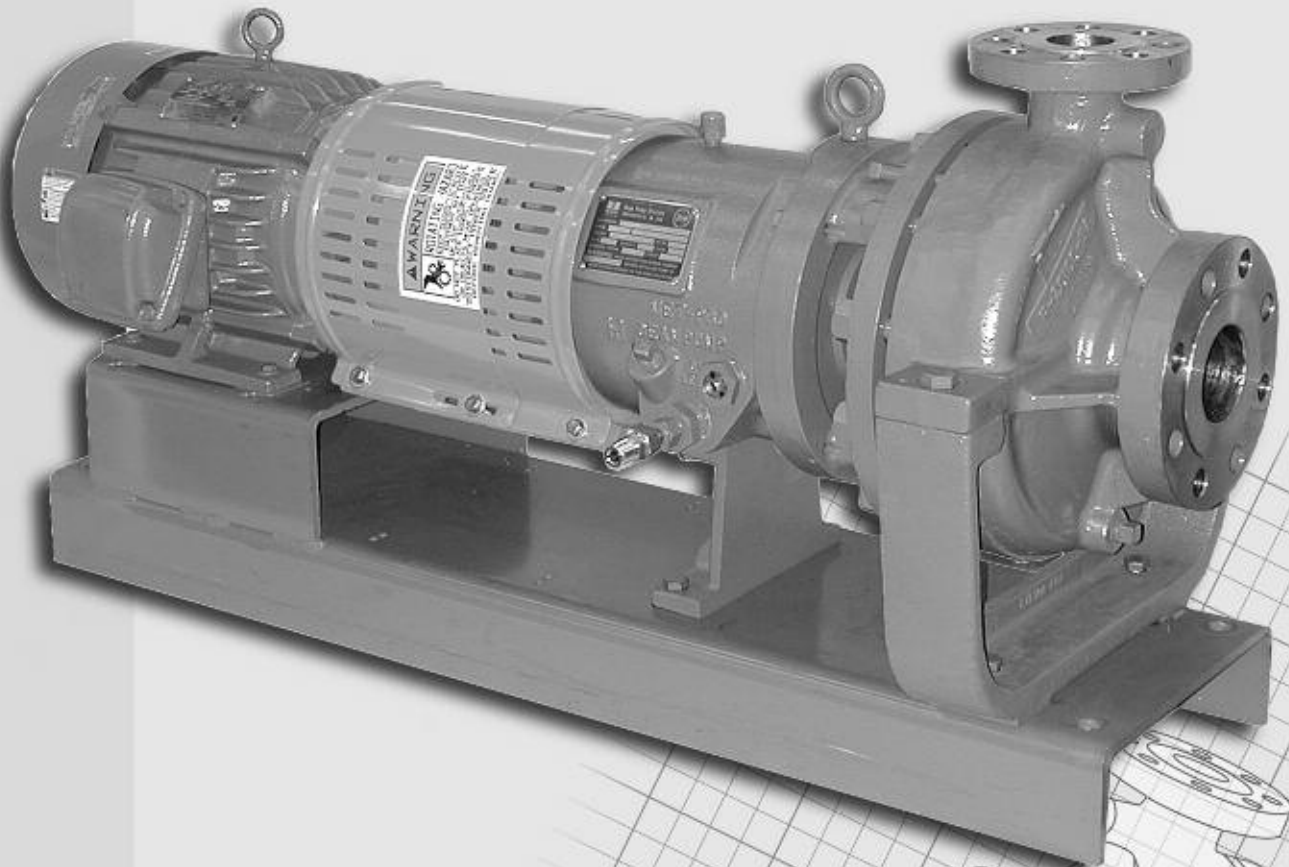

TWO POLE MOTOR

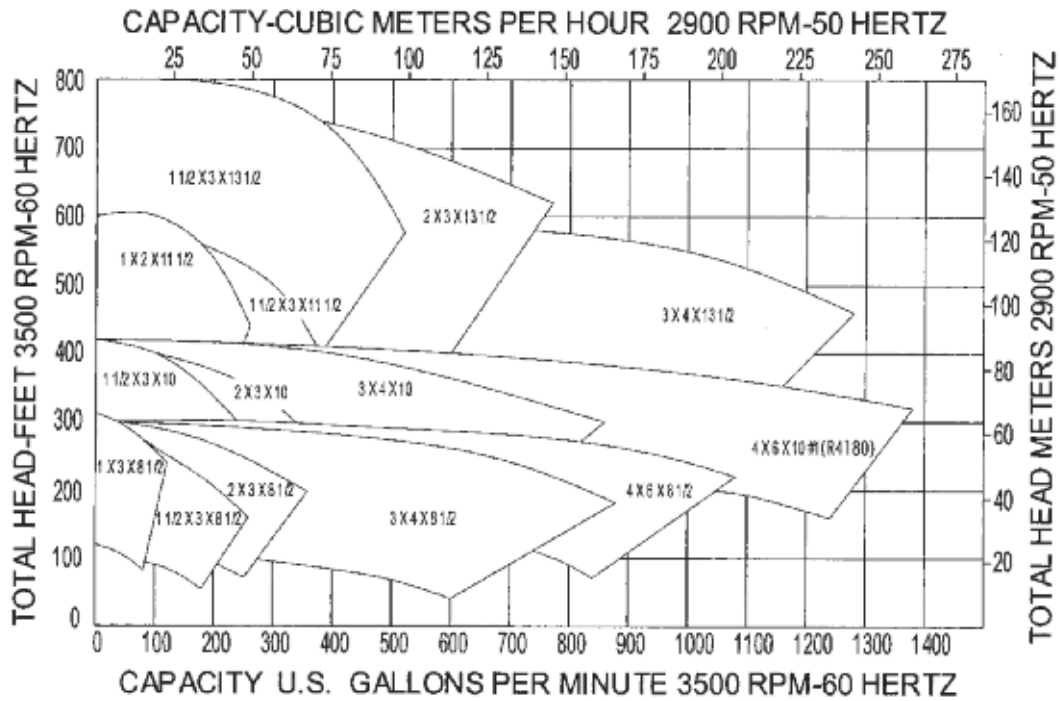

FOUR POLE MOTOR

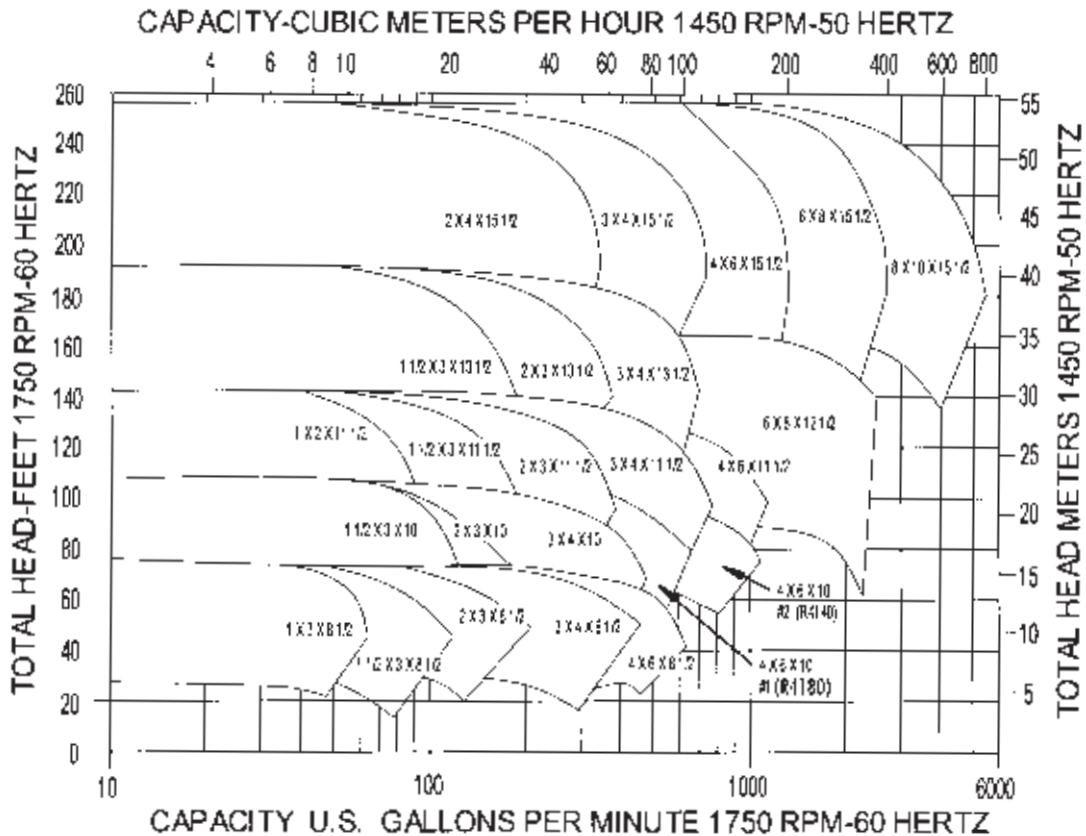

(317) 293-2930 • E-mail: info@deanpump.com

**STANDARD, HORIZONTAL, SINGLE STAGE, END SUCTION, ENCLOSED IMPELLER, CENTRIFUGAL PROCESS PUMPS
TYPES R4140, R4170, R4180 AND R4240**

MECHANICAL DESIGN SPECIFICATIONS

Direction of Rotation (Viewed from Coupling End)CCW
 Casing Thickness, Minimum5/16"
 Corrosion Allowance1/8"
 Impeller — StandardSingle Plane Balanced
 Optional ExtraDynamically Balanced
 Flanges — ANSI RatingClass 300
 FacingStandard Raised Face
 Optional ExtraRing Type Joint
 Finish125 Ra
 Seal Chamber & Bearing Housing Jacket Pressure, Maximum125 psig
 Suction Pressure, MaximumMax. Working Pressure Less Pump Developed Head

	R4140	R4170	R4180	R4240
Horsepower Rating — Maximum				
@ 3500 rpm	100	200	250	—
@ 1750 rpm	40	100	125	300
@ 1160 rpm	25	—	75	200
Bearings, Type Ball Bearings, Oil Lubricated				
Thrust Bearing (Angular Contact Pair)	7309BG	7311BG	7312BG	7317BG
Radial Bearing	6309	6311	6312	6316
Approximate Oil Capacity of Bearing Housing	41 oz	36 oz	64 oz	120 oz
Seal Chamber Dimensions (Large Taper Bore)				
Length (Depth)	3"	3"	4 1/2"	4 7/8"
Inside Diameter (Bore Diameter)	3 1/2"	3 7/8"	4 1/4"	5"
Shaft Sleeve Diameter	1 3/4"	2 1/8"	2 1/4"	3"
Standard Bore (Stuffing Box) Dimensions				
Length (Depth)	3"	3"	3 7/8"	4 1/8"
Inside Diameter (Bore Diameter)	2 1/2"	2 7/8"	3 1/4"	4"
Shaft Sleeve Diameter	1 3/4"	2 1/8"	2 1/4"	3"
Lantern Gland Width	5/8"	5/8"	3/4"	1"
Lantern Gland to Open End of Stuffing Box	1 1/2"	1 1/2"	1 1/2"	2 3/8"
Packing Size, Square	3/8"	3/8"	1/2"	1/2"
Number of Rings with Lantern Ring	6	6	6	6
Spacing	3G3	3G3	3G3	3G3
Number of Rings Lantern Omitted	7	8	7	8
Pump Shaft Dimensions				
Span Between Bearings C to C	6"	5 15/16"	8 1/4"	10 3/16"
Span Between Radial Bearing C and Impeller C	8"	8 3/16"	10 3/4"	12 5/16"
Diameter at Coupling	1 1/8"	1 5/8"	1 5/8"	2 3/8"
Diameter Between Bearings	2 1/8"	2 5/8"	2 3/4"	4"
Diameter at Impeller	1 1/8"	1 1/4"	1 1/2"	2 1/4"
L ³ /D ⁴				
Sleeved	101	44	78	36
Solid	55	27	26	23

MATERIAL CLASS	MAXIMUM WORKING PRESSURE	PUMPING TEMPERATURE		HYDROSTATIC TEST PRESSURE	
		MINIMUM	MAXIMUM	R4140/R4170	R4180/R4240
40†	500 psig @ 650°F	-20°F	800°F @ 350 psig	850 psig	750 psig
50	500 psig @ 100°F	-20°F	850°F @ 305 psig		

† Carbon Steel with Cast Iron trim. Also available with 316SS trim.

WARNING: Use the "Allowable Working Pressure VS. Pumping Temperature" chart (below, right) to determine the allowable working pressure at any allowable pumpage temperature for the material of construction selected.

Seal Chamber Temperature VS. Pumping Temperature
with respect to the GPM of cooling water flowing through the cooling jacket surrounding the seal chamber.

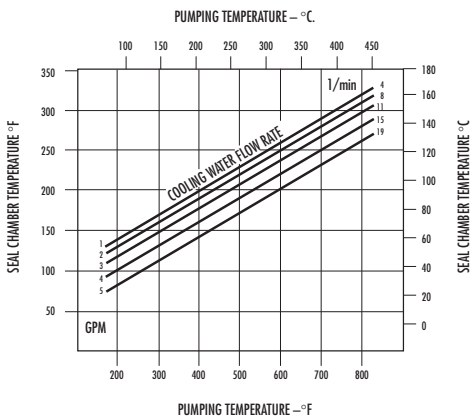

*GPM Flow Rate of Cooling Water Based on 70°F (21°C) Inlet Temp
Specifications are subject to change without notice

STANDARD MATERIALS OF CONSTRUCTION			
Part No.	Part Name	Carbon Steel (Cl. 40)	316SS (Cl. 50)
3	Impeller	C.I. (1)	316 (3)
*4	Impeller Key	Steel (2)	316 (8)
5	Casing	Steel (6)	316 (3)
5A	Casing Drain Plug	Steel (2)	316 (8)
5C	Casing Stud Nut	Steel (5)	
5D	Casing Stud	Steel (4)	
*6	Casing Back Cover Ring	Iron (7)	316 (3)
6A	Casing Ring	Iron (7)	316 (3)
7	Cradle Spacer	D.I. (16)	
7A	Bull's Eye Oil Level Indicator	Steel & Glass	
7G	Spacer to Bearing Housing Capscrew	Steel (2)	
9	Bearing Housing Foot	C.I. (1)	
*10	Shaft Sleeve	316 (8)	
*10K	Shaft Sleeve Key	304 (9)	
*12	Impeller Bolt (Nut on R4170)	Steel (2)	316 (8)
*12A	Impeller Washer	Steel (2)	316 (8)
*12B	Impeller Lock Washer		316 (8)
*12C	Impeller Washer Pin	304 (9)	316 (8)
13	Seal Chamber Gland	316 (8)	
	Packing Gland	Steel (6)	316 (3)
14	Gland Stud	Steel (4)	304 (9)
15	Gland Nut	Steel (5)	304 (9)
*17	Lantern Ring	C.I. (1)	316 (3)
22	Casing Back Cover	Steel (6)	316 (3)
*22A	Back Cover to Cradle Cap Screw	Steel (2)	
*25	Radial Bearing	—	—
*25A	Thrust Bearing	—	—
*26	Bearing Housing	C.I. (1)	
*27	Seal Ring	C.I. (1)	
*28	Bearing End Cover	C.I. (1)	
*28A	Bearing End Cover Cap Screw	Steel (2)	
*29	Pump Shaft	Steel (10)	316 (8)
*31	Thrust Bearing Lock Nut	Steel (2)	
*31A	Thrust Bearing Lock Washer	Steel (2)	
*54	Throat Bushing	C.I. (1)	316 (8)
56	Casing Foot	C.I. (1)	
*56B	Casing Foot Dowel	Steel (2)	
*75B	Retaining Ring (All Except R4240)	Steel	
*76	Labyrinth Seal—Front	Bronze & Viton ††	
*76A	Labyrinth Seal—Rear	Bronze & Viton †	
77	Casing Gasket	Grafoil (1.1)	
*77B	End Cover Gasket	Buna (1.4)	
*80	Bearing Housing Vent	—	—
*83	Motor Support (C Face)	C.I. (1)	
*87	Impeller Ring—Back (Optional)	Steel (2)	316 (3)
87A	Impeller Ring—Front (Optional)	Steel (2)	316 (3)
95A	Mechanical Seal Stationary	—	—
95B	Mechanical Seal Rotary	—	—
*109	Oil Cooler	SS Tubing with Steel Fins	

† Denotes parts interchangeable in all pump sizes of same type. © Registered trademark of the E.I. DuPont Co.

MATERIAL SPECIFICATIONS (REFER TO NUMBERS IN PARENTHESES)

- | | |
|---|---|
| (1) Cast Iron | (9) AISI—304SS |
| (2) AISI 1020 | (10) Alloy Steel—125,000 TS, 100,000 YP |
| (3) 316SS — ASTM #A744 Grade CF8M | (11) Grafoil — Registered trademark of Union Carbide Corp. |
| (4) AISI 4140, ASTM #A193-B7 Steel | (12) Manila Paper |
| (5) ASTM #A194 Grade 2 Steel | (13) Fibre Sheet — Non-Asbestos Fibre |
| (6) ASTM #A216 Grade WCB Cast Steel (-20 + 800°F) | (14) Buna N Rubber |
| (7) Hardened Iron | (15) Steel Finned, Stainless Steel Tube with Steel End Fittings |
| (8) AISI—316SS | (16) Ductile Iron — ASTM-A536 Class 65-45-12 |

SEAL CHAMBER PRESSURE - R4000 SERIES PUMPS

**With Impeller Balance Holes—Seal Chamber Pressure Equals Pump Suction Pressure Plus .06 x Pump Developed Pressure in PSI
 Without Impeller Balance Holes—Seal Chamber Pressure Equals Pump Suction Pressure Plus .75 x Pump Developed Pressure in PSI
 Pumps are normally furnished with balance holes

R4000 Series Pumps – Allowable Working Pressure VS Pumping Temperature

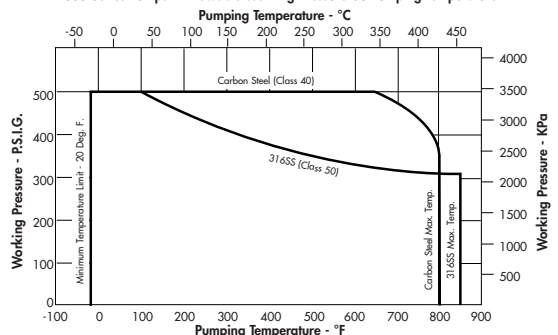

R4140 CROSS SECTION

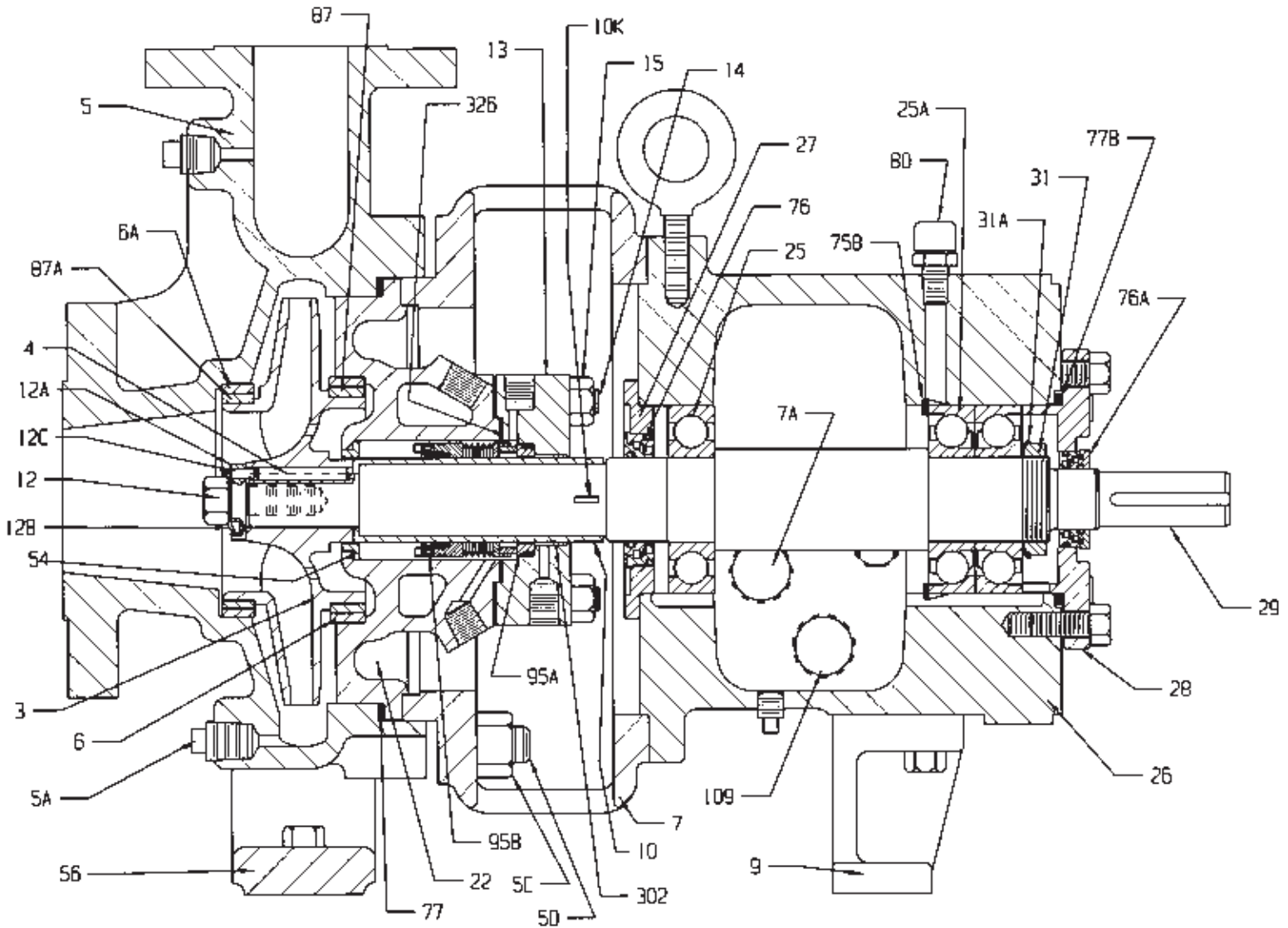

R4140 CROSS SECTION WITH
"C" FACE MOTOR SUPPORT

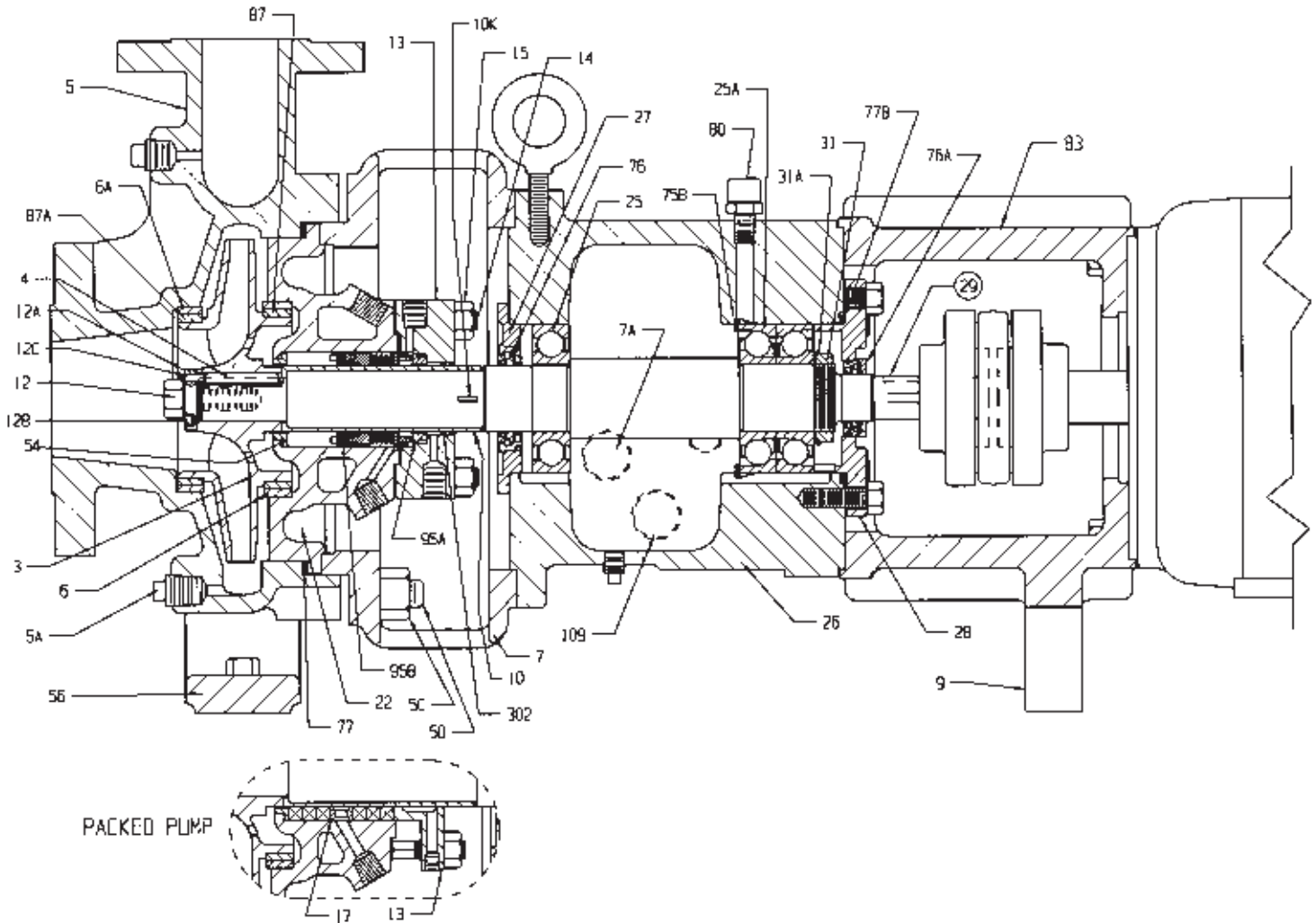

R4170 CROSS SECTION

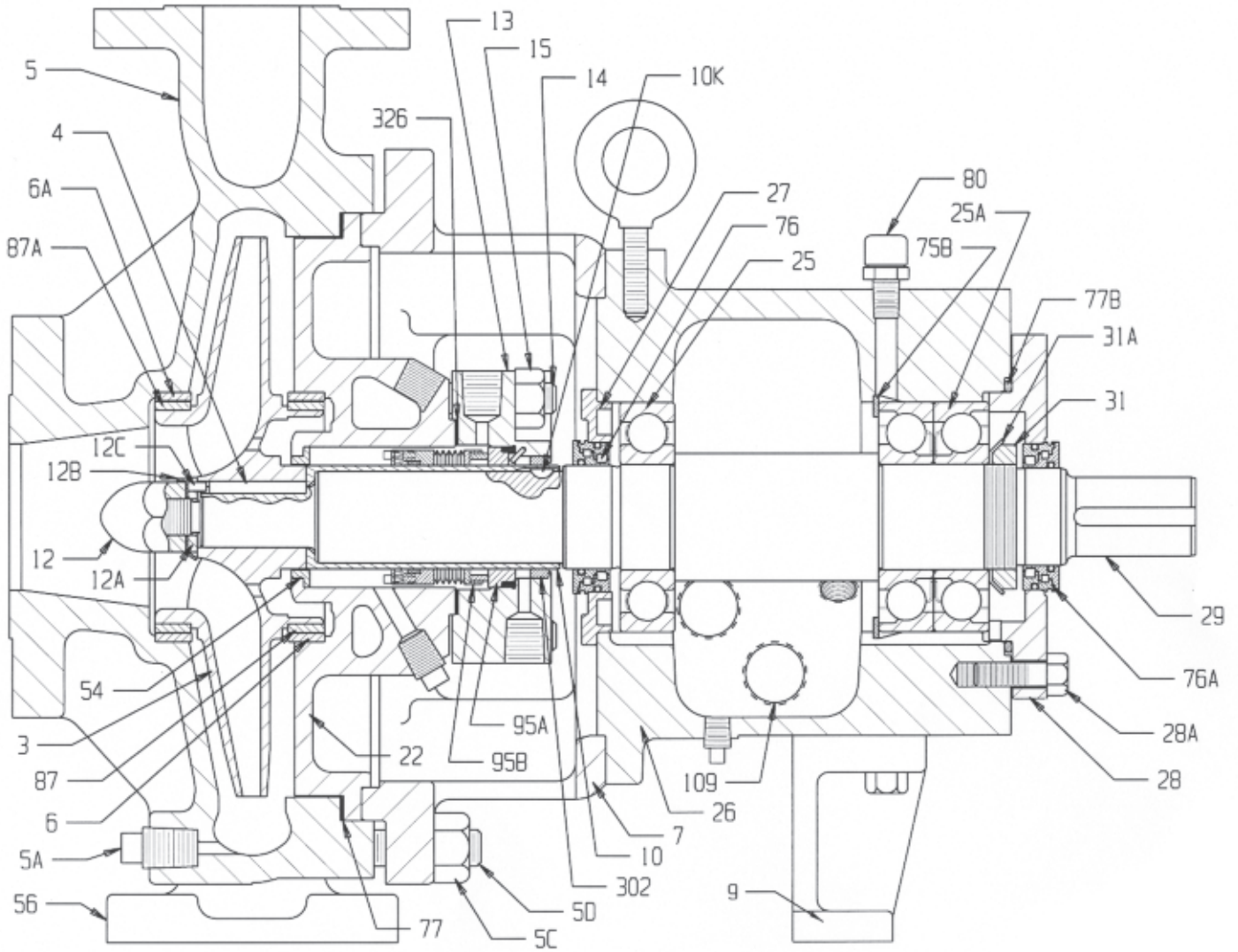

R4180 CROSS SECTION

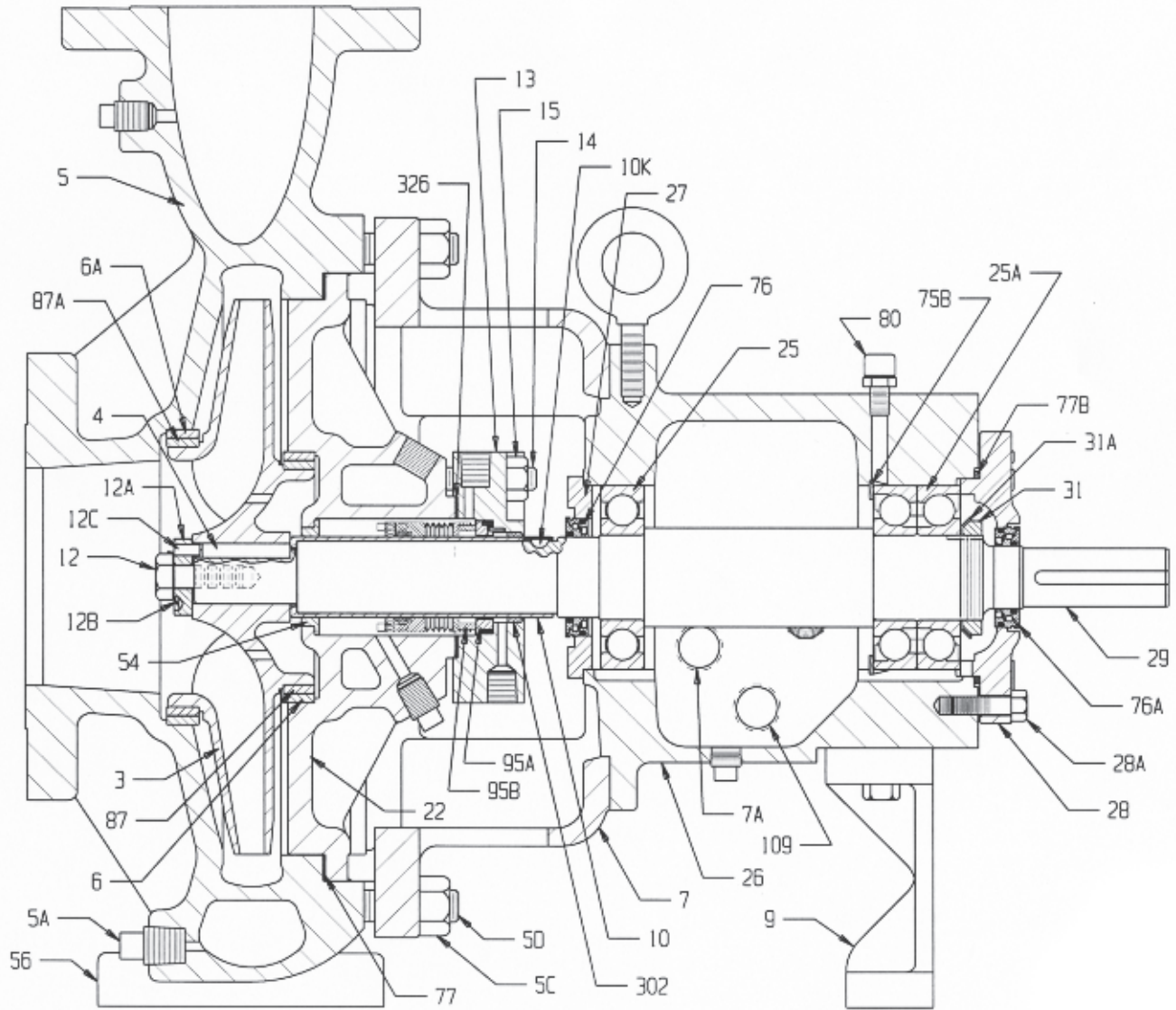

R4240 CROSS SECTION

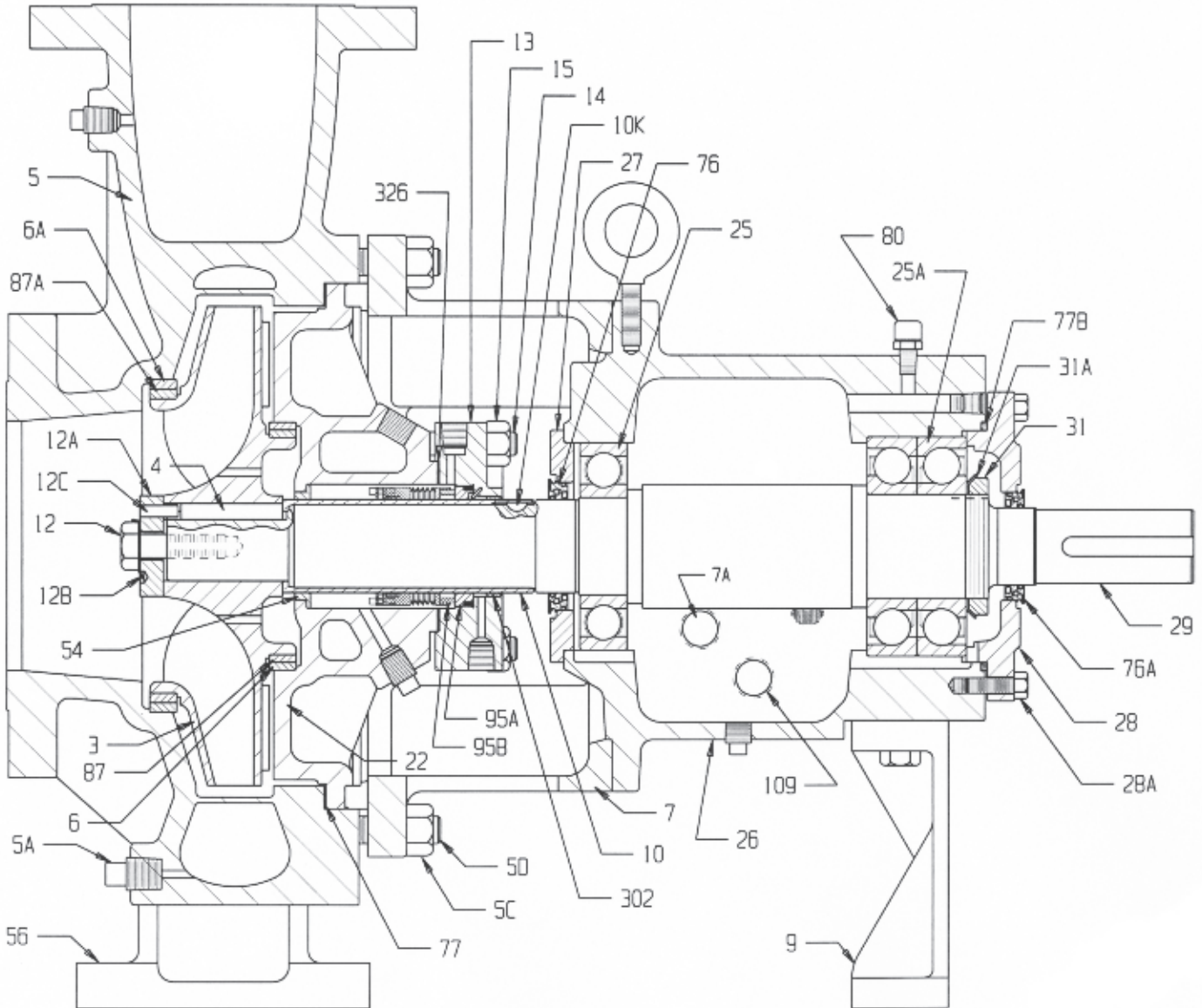

STANDARD, END SUCTION, CLOSED IMPELLER, CENTRIFUGAL PROCESS PUMP
TYPE R4140 WITH PEDESTAL FEET

FLANGES:
A.N.S.I. Class 300
FACING Raised Face
FINISH 125 Ra

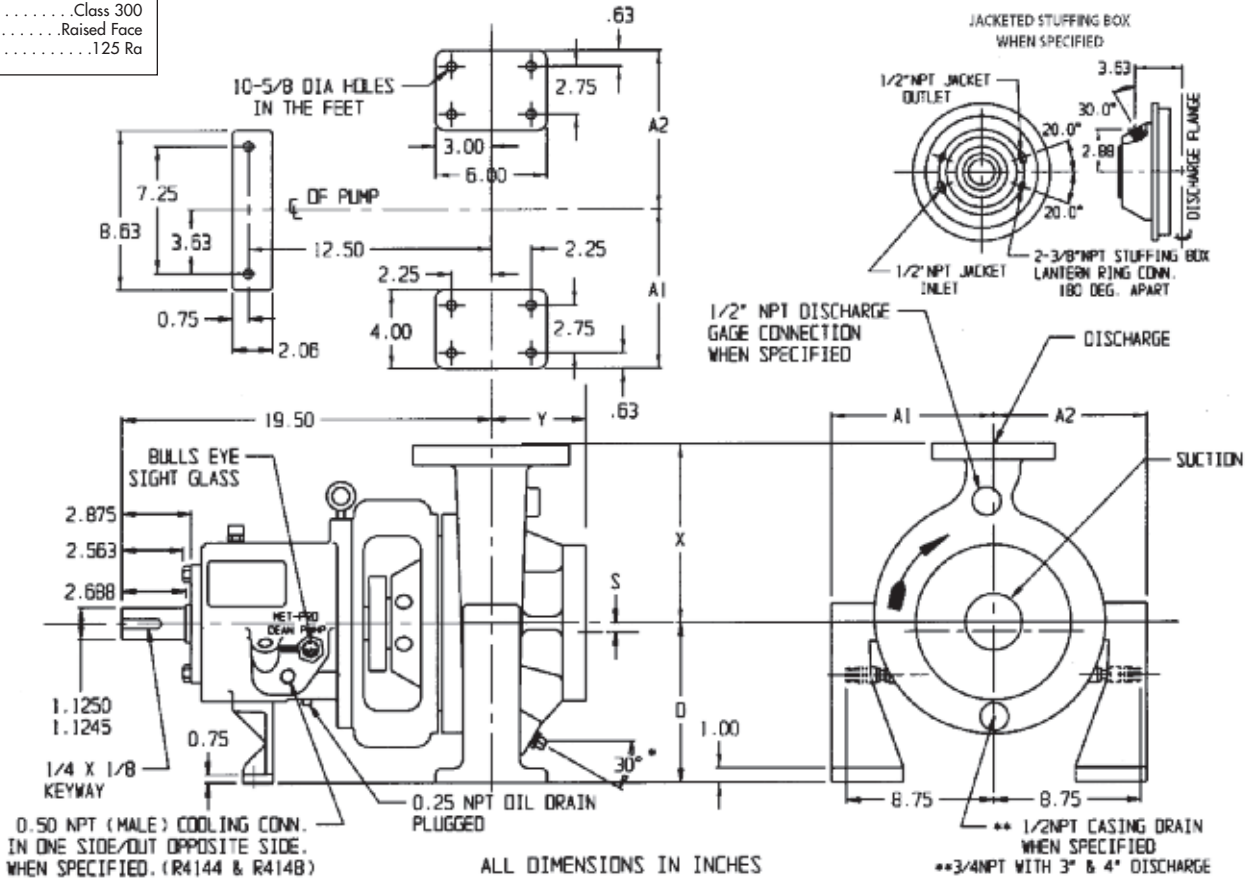

PUMP SIZE	DISCHARGE					SUCTION					A ₁	A ₂	D	S	X	Y
	SIZE	O.D.	THK	B.C.	BOLTS	SIZE	O.D.	THK	B.C.	BOLTS						
*1 x 3 x 8 1/2	1	4 7/8	1 1/16	3 1/2	4-5/8	3	8 1/4	1 1/8	6 5/8	8-3/4	8 1/8	8 1/8	8 1/4	0	7 1/2	4
1 1/2 x 3 x 8 1/2	1 1/2	6 1/8	1 3/16	4 1/2	4-3/4	3	8 1/4	1 1/8	6 5/8	8-3/4	8 1/8	8 1/8	8 1/4	0	8 1/2	4
2 x 3 x 8 1/2	2	6 1/2	7/8	5	8-5/8	3	8 1/4	1 1/8	6 5/8	8-3/4	8 1/8	8 1/8	8 1/4	0	9 1/2	5
*3 x 4 x 8 1/2	3	8 1/4	1 1/8	6 5/8	8-3/4	4	10	1 1/4	7 7/8	8-3/4	9	8 1/8	10	0	11	5
*4 x 6 x 8 1/2	4	10	1 1/4	7 7/8	8-3/4	6	12 1/2	1 7/16	10 5/8	12-3/4	10 1/4	8 1/8	10	5/8	11 1/2	6
1 1/2 x 3 x 10	1 1/2	6 1/8	1 3/16	4 1/2	4-3/4	3	8 1/4	1 1/8	6 5/8	8-3/4	9	8 3/4	10	0	9	4
2 x 3 x 10	2	6 1/2	7/8	5	8-5/8	3	8 1/4	1 1/8	6 5/8	8-3/4	9	8 3/4	10	0	9 1/2	5
3 x 4 x 10	3	8 1/4	1 1/8	6 5/8	8-3/4	4	10	1 1/4	7 7/8	8-3/4	10 3/8	8 3/4	10	0	11	5
4 x 6 x 10 #2	4	10	1 1/4	7 7/8	8-3/4	6	12 1/2	1 7/16	10 5/8	12-3/4	11 3/4	10	1 1/2	1/8	12 1/2	6
1 x 2 x 11 1/2	1	4 7/8	1 1/16	3 1/2	4-5/8	2	6 1/2	7/8	5	8-5/8	9 3/4	9 3/4	10	0	9	5
1 1/2 x 3 x 11 1/2	1 1/2	6 1/8	1 3/16	4 1/2	4-3/4	3	8 1/4	1 1/8	6 5/8	8-3/4	9 3/4	9 3/4	10	0	10 1/2	4
2 x 3 x 11 1/2	2	6 1/2	7/8	5	8-5/8	3	8 1/4	1 1/8	6 5/8	8-3/4	10 1/4	9 3/4	10	0	10 1/2	5
3 x 4 x 11 1/2	3	8 1/4	1 1/8	6 5/8	8-3/4	4	10	1 1/4	7 7/8	8-3/4	11 1/4	10	1 1/2	0	12 1/2	6
4 x 6 x 11 1/2	4	10	1 1/4	7 7/8	8-3/4	6	12 1/2	1 7/16	10 5/8	12-3/4	11 3/4	10 1/2	1 1/2	3/8	13 1/2	6
1 1/2 x 3 x 13 1/2	1 1/2	6 1/8	1 3/16	4 1/2	4-3/4	3	8 1/4	1 1/8	6 5/8	8-3/4	11 1/2	11 1/2	11 1/2	0	11	5
2 x 3 x 13 1/2	2	6 1/2	7/8	5	8-5/8	3	8 1/4	1 1/8	6 5/8	8-3/4	11 1/2	11 1/2	11 1/2	0	11 1/2	5
3 x 4 x 13 1/2	3	8 1/4	1 1/8	6 5/8	8-3/4	4	10	1 1/4	7 7/8	8-3/4	12	11 1/2	11 1/2	0	12 1/2	6

All dimensions in inches

IMPORTANT: DO NOT USE FOR CONSTRUCTION UNLESS CERTIFIED.

DIMENSION DWG.
NO. R-1005

STANDARD, END SUCTION, CLOSED IMPELLER, CENTRIFUGAL PROCESS PUMP
TYPE R4140 WITH YOKE FOOT

FLANGES:
A.N.S.I. Class 300
FACING Raised Face
FINISH 125 Ra

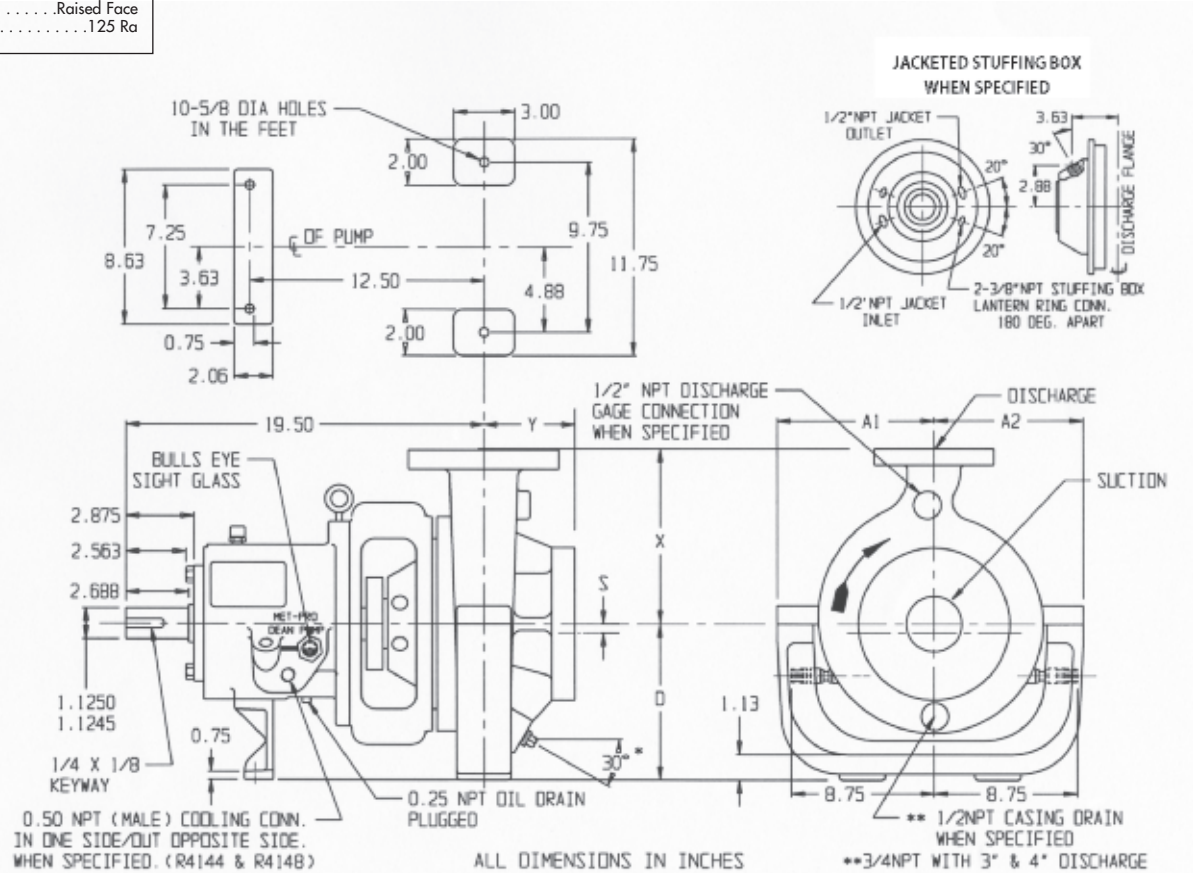

PUMP SIZE	DISCHARGE					SUCTION					A ₁	A ₂	D	S	X	Y
	SIZE	O.D.	THK	B.C.	BOLTS	SIZE	O.D.	THK	B.C.	BOLTS						
*1 x 3 x 8 1/2	1	47/8	11/16	3 1/2	4-5/8	3	8 1/4	11/8	65/8	8-3/4	8 1/8	8 1/8	8 1/4	0	7 1/2	4
1 1/2 x 3 x 8 1/2	1 1/2	6 1/8	13/16	4 1/2	4-3/4	3	8 1/4	11/8	65/8	8-3/4	8 1/8	8 1/8	8 1/4	0	8 1/2	4
2 x 3 x 8 1/2	2	6 1/2	7/8	5	8-5/8	3	8 1/4	11/8	65/8	8-3/4	8 1/8	8 1/8	8 1/4	0	9 1/2	5
*3 x 4 x 8 1/2	3	8 1/4	1 1/8	65/8	8-3/4	4	10	1 1/4	77/8	8-3/4	9	8 1/8	10	0	11	5
*4 x 6 x 8 1/2	4	10	1 1/4	77/8	8-3/4	6	12 1/2	17/16	105/8	12-3/4	10 1/4	8 1/8	10	5/8	11 1/2	6
1 1/2 x 3 x 10	1 1/2	6 1/8	13/16	4 1/2	4-3/4	3	8 1/4	11/8	65/8	8-3/4	9	8 3/4	10	0	9	4
2 x 3 x 10	2	6 1/2	7/8	5	8-5/8	3	8 1/4	11/8	65/8	8-3/4	9	8 3/4	10	0	9 1/2	5
3 x 4 x 10	3	8 1/4	1 1/8	65/8	8-3/4	4	10	1 1/4	77/8	8-3/4	10 3/8	8 3/4	10	0	11	5
4 x 6 x 10 #2	4	10	1 1/4	77/8	8-3/4	6	12 1/2	17/16	105/8	12-3/4	11 3/4	10	11 1/2	1/8	12 1/2	6
1 x 2 x 11 1/2	1	47/8	11/16	3 1/2	4-5/8	2	6 1/2	7/8	5	8-5/8	9 3/4	9 3/4	10	0	9	5
1 1/2 x 3 x 11 1/2	1 1/2	6 1/8	13/16	4 1/2	4-3/4	3	8 1/4	11/8	65/8	8-3/4	9 3/4	9 3/4	10	0	10 1/2	4
2 x 3 x 11 1/2	2	6 1/2	7/8	5	8-5/8	3	8 1/4	11/8	65/8	8-3/4	10 1/4	9 3/4	10	0	10 1/2	5
3 x 4 x 11 1/2	3	8 1/4	1 1/8	65/8	8-3/4	4	10	1 1/4	77/8	8-3/4	11 1/4	10	11 1/2	0	12 1/2	6
4 x 6 x 11 1/2	4	10	1 1/4	77/8	8-3/4	6	12 1/2	17/16	105/8	12-3/4	11 3/4	10 1/2	11 1/2	3/8	13 1/2	6
1 1/2 x 3 x 13 1/2	1 1/2	6 1/8	13/16	4 1/2	4-3/4	3	8 1/4	11/8	65/8	8-3/4	11 1/2	11 1/2	11 1/2	0	11	5
2 x 3 x 13 1/2	2	6 1/2	7/8	5	8-5/8	3	8 1/4	11/8	65/8	8-3/4	11 1/2	11 1/2	11 1/2	0	11 1/2	5
3 x 4 x 13 1/2	3	8 1/4	1 1/8	65/8	8-3/4	4	10	1 1/4	77/8	8-3/4	12	11 1/2	11 1/2	0	12 1/2	6

All dimensions in inches

**STANDARD, END SUCTION, CLOSED IMPELLER, CENTRIFUGAL PROCESS PUMP
TYPE R4140 WITH REFINERY TYPE BASE**

FLANGES:
A.N.S.I. Class 300
FACING Raised Face
FINISH 125 Ra

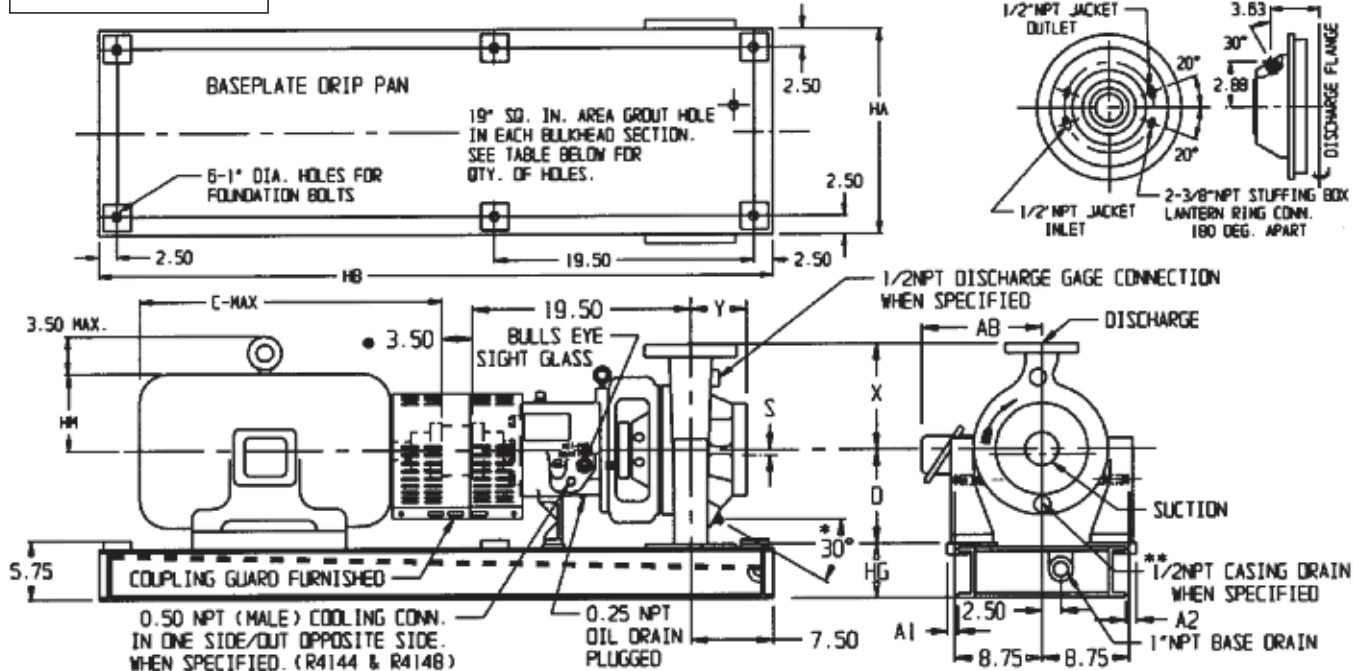

PUMP SIZE	DISCHARGE					SUCTION					A ₁	A ₂	D	S	X	Y
	SIZE	O.D.	THK	B.C.	BOLTS	SIZE	O.D.	THK	B.C.	BOLTS						
*1 x 3 x 8 1/2	1	4 7/8	1 1/16	3 1/2	4-5/8	3	8 1/4	1 1/8	6 5/8	8-3/4	0	0	8 1/4	0	7 1/2	4
1 1/2 x 3 x 8 1/2	1 1/2	6 1/8	1 3/16	4 1/2	4-3/4	3	8 1/4	1 1/8	6 5/8	8-3/4	0	0	8 1/4	0	8 1/2	4
2 x 3 x 8 1/2	2	6 1/2	7/8	5	8-5/8	3	8 1/4	1 1/8	6 5/8	8-3/4	0	0	8 1/4	0	9 1/2	5
*3 x 4 x 8 1/2	3	8 1/4	1 1/8	6 5/8	8-3/4	4	10	1 1/4	7 7/8	8-3/4	0	3/8	10	0	11	5
*4 x 6 x 8 1/2	4	10	1 1/4	7 7/8	8-3/4	6	12 1/2	1 7/16	10 5/8	12-3/4	0	3/8	10	5/8	11 1/2	6
1 1/2 x 3 x 10	1 1/2	6 1/8	1 3/16	4 1/2	4-3/4	3	8 1/4	1 1/8	6 5/8	8-3/4	0	3/8	10	0	9	4
2 x 3 x 10	2	6 1/2	7/8	5	8-5/8	3	8 1/4	1 1/8	6 5/8	8-3/4	0	3/8	10	0	9 1/2	5
3 x 4 x 10	3	8 1/4	1 1/8	6 5/8	8-3/4	4	10	1 1/4	7 7/8	8-3/4	0	3/8	10	0	11	5
4 x 6 x 10 #2	4	10	1 1/4	7 7/8	8-3/4	6	12 1/2	1 7/16	10 5/8	12-3/4	1/4	1	11 1/2	1/8	12 1/2	6
1 x 2 x 11 1/2	1	4 7/8	1 1/16	3 1/2	4-5/8	2	6 1/2	7/8	5	8-5/8	0	3/8	10	0	9	5
1 1/2 x 3 x 11 1/2	1 1/2	6 1/8	1 3/16	4 1/2	4-3/4	3	8 1/4	1 1/8	6 5/8	8-3/4	0	3/8	10	0	10 1/2	4
2 x 3 x 11 1/2	2	6 1/2	7/8	5	8-5/8	3	8 1/4	1 1/8	6 5/8	8-3/4	0	3/8	10	0	10 1/2	5
3 x 4 x 11 1/2	3	8 1/4	1 1/8	6 5/8	8-3/4	4	10	1 1/4	7 7/8	8-3/4	1/4	1	11 1/2	0	12 1/2	6
4 x 6 x 11 1/2	4	10	1 1/4	7 7/8	8-3/4	6	12 1/2	1 7/16	10 5/8	12-3/4	1/4	1	11 1/2	3/8	13 1/2	6
1 1/2 x 3 x 13 1/2	1 1/2	6 1/8	1 3/16	4 1/2	4-3/4	3	8 1/4	1 1/8	6 5/8	8-3/4	1/4	1	11 1/2	0	11	5
2 x 3 x 13 1/2	2	6 1/2	7/8	5	8-5/8	3	8 1/4	1 1/8	6 5/8	8-3/4	1/4	1	11 1/2	0	11 1/2	5
3 x 4 x 13 1/2	3	8 1/4	1 1/8	6 5/8	8-3/4	4	10	1 1/4	7 7/8	8-3/4	1/4	1	11 1/2	0	12 1/2	6

FRAME	C	AB	HA			HB	HG		HM	Qty. of Grout Holes	
			D=8 1/4	D=10	D=11 1/2		D=8 1/4	D=10 & 11 1/2		D=8 1/4	D=10 & 11 1/2
143T	13 1/4	6 1/2	18	21	23	50	5 1/8	5 1/8	3 7/8	3	3
145T	13 3/4	6 1/2	18	21	23	50	5 1/8	5 1/8	3 7/8	3	3
182T	14 5/8	7 1/2	18	21	23	50	5 1/8	5 1/8	5 1/4	3	3
184T	15 5/8	7 1/2	18	21	23	50	5 1/8	5 1/8	5 1/4	3	3
213T	18 1/8	9 1/2	18	21	23	50	5 1/8	5 1/8	6	3	3
215T	19 5/8	9 1/2	18	21	23	50	5 1/8	5 1/8	6	3	3
254T	23 1/8	10 3/4	21	21	23	58	5 1/8	5 1/8	7	4	4
256T	24 7/8	10 3/4	21	21	23	58	5 1/8	5 1/8	7	4	4
284T	26 7/8	12 5/8	21	21	23	58	5 1/8	5 1/8	7 3/4	4	4
284TS	25 1/2	12 5/8	21	21	23	58	5 1/8	5 1/8	7 3/4	4	4
286T	28 3/8	12 5/8	21	21	23	58	5 1/8	5 1/8	7 3/4	4	4

FRAME	C	AB	HA			HB	HG		HM	Qty. of Grout Holes	
			D=8 1/4	D=10	D=11 1/2		D=8 1/4	D=10 & 11 1/2		D=8 1/4	D=10 & 11 1/2
286TS	27	12 5/8	21	21	23	58	5 1/8	5 1/8	7 3/4	4	4
324T	29 7/8	14 3/4	18	22	23	62	6 3/8	5 1/8	8 3/4	3	4
324TS	28 3/8	14 3/4	18	22	23	62	6 3/8	5 1/8	8 3/4	3	4
326T	31 3/8	14 3/4	18	22	23	62	6 3/8	5 1/8	8 3/4	3	4
326TS	29 7/8	14 3/4	18	22	23	62	6 3/8	5 1/8	8 3/4	3	4
364T	33 1/8	15 5/8	18	22	23	62	6 3/8	5 1/8	9 7/8	3	4
364TS	31 1/2	15 5/8	18	22	23	62	6 3/8	5 1/8	9 7/8	3	4
365T	34 1/8	15 5/8	18	22	23	62	6 3/8	5 1/8	9 7/8	3	4
365TS	32 1/2	15 5/8	18	22	23	62	6 3/8	5 1/8	9 7/8	3	4
405TS	38 1/2	19 3/4	20	24	25	68	6 3/8	5 1/8	11	3	4
444TS	45	21 1/2	22	26	27	76	6 3/8	5 1/8	12 1/4	3	4

All dimensions in inches

** 3/4 NPT with 3" & 4" discharge

• Spacer is 5" for motor frames 405TS and 444TS

IMPORTANT: DO NOT USE FOR CONSTRUCTION UNLESS CERTIFIED.

**DIMENSION DWG.
NO. R-1040**

(317) 293-2930 • E-mail: info@deanpump.com

STANDARD, END SUCTION, CLOSED IMPELLER, CENTRIFUGAL PROCESS PUMP
TYPE R4140 WITH BENT STEEL BASE

FLANGES:
A.N.S.I. Class 300
FACING Raised Face
FINISH 125 Ra

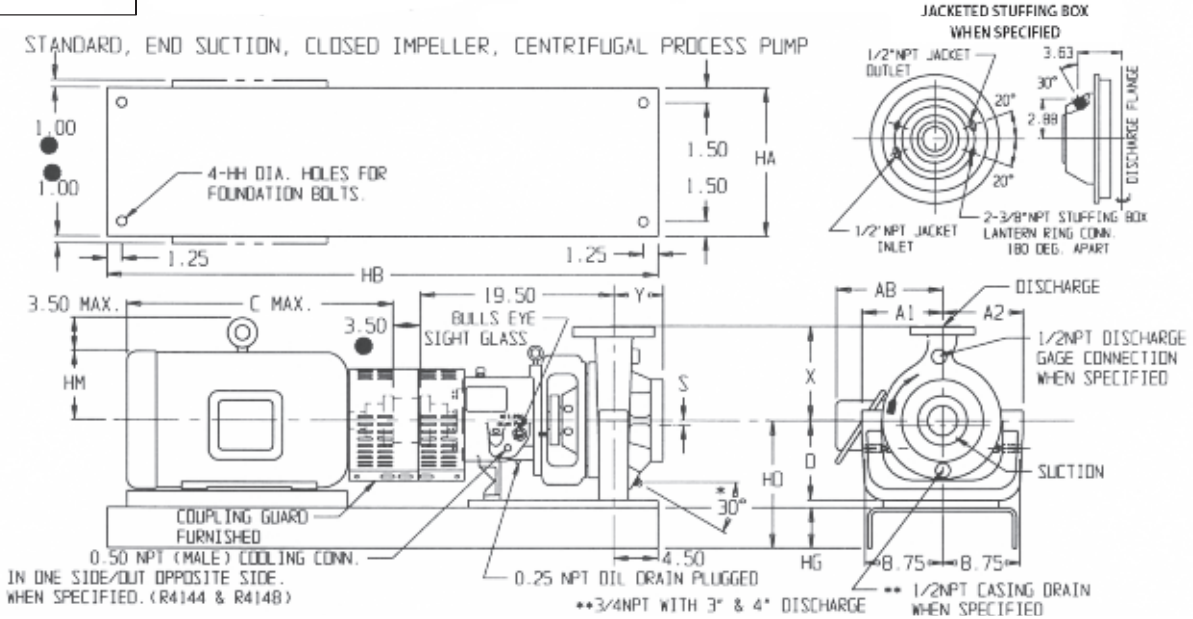

** 3/4 NPT with 3\" & 4\" discharge

PUMP SIZE	DISCHARGE					SUCTION					A ₁	A ₂	D	S	X	Y
	SIZE	O.D.	THK	B.C.	BOLTS	SIZE	O.D.	THK	B.C.	BOLTS						
*1 x 3 x 8 1/2	1	4 7/8	1 1/16	3 1/2	4-5/8	3	8 1/4	1 1/8	6 5/8	8-3/4	8 1/8	8 1/8	8 1/4	0	7 1/2	4
1 1/2 x 3 x 8 1/2	1 1/2	6 1/8	1 3/16	4 1/2	4-3/4	3	8 1/4	1 1/8	6 5/8	8-3/4	8 1/8	8 1/8	8 1/4	0	8 1/2	4
2 x 3 x 8 1/2	2	6 1/2	7/8	5	8-5/8	3	8 1/4	1 1/8	6 5/8	8-3/4	8 1/8	8 1/8	8 1/4	0	9 1/2	5
*3 x 4 x 8 1/2	3	8 1/4	1 1/8	6 5/8	8-3/4	4	10	1 1/4	7 7/8	8-3/4	9	8 1/8	10	0	11	5
*4 x 6 x 8 1/2	4	10	1 1/4	7 7/8	8-3/4	6	12 1/2	1 7/16	10 5/8	12-3/4	10 1/4	8 1/8	10	5/8	11 1/2	6
1 1/2 x 3 x 10	1 1/2	6 1/8	1 3/16	4 1/2	4-3/4	3	8 1/4	1 1/8	6 5/8	8-3/4	9	8 3/4	10	0	9	4
2 x 3 x 10	2	6 1/2	7/8	5	8-5/8	3	8 1/4	1 1/8	6 5/8	8-3/4	9	8 3/4	10	0	9 1/2	5
3 x 4 x 10	3	8 1/4	1 1/8	6 5/8	8-3/4	4	10	1 1/4	7 7/8	8-3/4	10 3/8	8 3/4	10	0	11	5
4 x 6 x 10 #2	4	10	1 1/4	7 7/8	8-3/4	6	12 1/2	1 7/16	10 5/8	12-3/4	11 3/4	10	11 1/2	1/8	12 1/2	6
1 x 2 x 11 1/2	1	4 7/8	1 1/16	3 1/2	4-5/8	2	6 1/2	7/8	5	8-5/8	9 3/4	9 3/4	10	0	9	5
1 1/2 x 3 x 11 1/2	1 1/2	6 1/8	1 3/16	4 1/2	4-3/4	3	8 1/4	1 1/8	6 5/8	8-3/4	9 3/4	9 3/4	10	0	10 1/2	4
2 x 3 x 11 1/2	2	6 1/2	7/8	5	8-5/8	3	8 1/4	1 1/8	6 5/8	8-3/4	10 1/4	9 3/4	10	0	10 1/2	5
3 x 4 x 11 1/2	3	8 1/4	1 1/8	6 5/8	8-3/4	4	10	1 1/4	7 7/8	8-3/4	11 1/4	10	11 1/2	0	12 1/2	6
4 x 6 x 11 1/2	4	10	1 1/4	7 7/8	8-3/4	6	12 1/2	1 7/16	10 5/8	12-3/4	11 3/4	10 1/2	11 1/2	3/8	13 1/2	6
1 1/2 x 3 x 13 1/2	1 1/2	6 1/8	1 3/16	4 1/2	4-3/4	3	8 1/4	1 1/8	6 5/8	8-3/4	11 1/2	11 1/2	11 1/2	0	11	5
2 x 3 x 13 1/2	2	6 1/2	7/8	5	8-5/8	3	8 1/4	1 1/8	6 5/8	8-3/4	11 1/2	11 1/2	11 1/2	0	11 1/2	5
3 x 4 x 13 1/2	3	8 1/4	1 1/8	6 5/8	8-3/4	4	10	1 1/4	7 7/8	8-3/4	12	11 1/2	11 1/2	0	12 1/2	6

All dimensions in inches

FRAME	C	AB	HA	HB	HD			HG	HH	HM
					D=8 1/4	D=10	D=11 1/2			
143T	13 1/4	6 1/2	12	45	12	13 3/4	15 1/4	3 3/4	3/4	3 7/8
145T	13 3/4	6 1/2	12	45	12	13 3/4	15 1/4	3 3/4	3/4	3 7/8
182T	14 5/8	7 1/2	12	45	12	13 3/4	15 1/4	3 3/4	3/4	5 1/4
184T	15 5/8	7 1/2	12	45	12	13 3/4	15 1/4	3 3/4	3/4	5 1/4
213T	18 1/8	9 1/2	12	45	12	13 3/4	15 1/4	3 3/4	3/4	6
215T	19 5/8	9 1/2	12	45	12	13 3/4	15 1/4	3 3/4	3/4	6
254T	23 1/8	10 3/4	15	52	12 3/8	14 1/8	15 5/8	4 1/8	3/4	7
256T	24 7/8	10 3/4	15	52	12 3/8	14 1/8	15 5/8	4 1/8	3/4	7
284T	26 7/8	12 5/8	15	52	12 3/8	14 1/8	15 5/8	4 1/8	3/4	7 3/4
284TS	25 1/2	12 5/8	15	52	12 3/8	14 1/8	15 5/8	4 1/8	3/4	7 3/4
286T	28 3/8	12 5/8	15	52	12 3/8	14 1/8	15 5/8	4 1/8	3/4	7 3/4

All dimensions in inches

FRAME	C	AB	HA	HB	HD			HG	HH	HM
					D=8 1/4	D=10	D=11 1/2			
286TS	27	12 5/8	15	52	12 3/8	14 1/8	15 5/8	4 1/8	3/4	7 3/4
324T	29 7/8	14 3/4	18	58	13	14 3/4	16 1/4	4 3/4	1	8 3/4
324TS	28 3/8	14 3/4	18	58	13	14 3/4	16 1/4	4 3/4	1	8 3/4
326T	31 3/8	14 3/4	18	58	13	14 3/4	16 1/4	4 3/4	1	8 3/4
326TS	29 7/8	14 3/4	18	58	13	14 3/4	16 1/4	4 3/4	1	8 3/4
364T	33 1/8	15 5/8	18	58	13 7/8	14 3/4	16 1/4	4 3/4	1	9 7/8
364TS	31 1/2	15 5/8	18	58	13 7/8	14 3/4	16 1/4	4 3/4	1	9 7/8
365T	34 1/8	15 5/8	18	58	13 7/8	14 3/4	16 1/4	4 3/4	1	9 7/8
365TS	32 1/2	15 5/8	18	58	13 7/8	14 3/4	16 1/4	4 3/4	1	9 7/8
404TS	33 1/2	17 1/2	18	60	—	14 3/4	16 1/4	4 5/8	1	11
405TS	35	17 1/2	18	60	—	14 3/4	16 1/4	4 5/8	1	11

● These 1.00 dimensions apply to motor frames 404TS and 405TS only
● The 3.50 dimension becomes 5.00 for motor frames 404TS and 405TS only

IMPORTANT: DO NOT USE FOR CONSTRUCTION UNLESS CERTIFIED.

DIMENSION DWG.
NO. R-1025

STANDARD, END SUCTION, CLOSED IMPELLER, CENTRIFUGAL PROCESS PUMP
TYPE R4140 WITH "C" FACE MOTOR

FLANGES:
A.N.S.I. Class 300
FACING Raised Face
FINISH 125 Ra

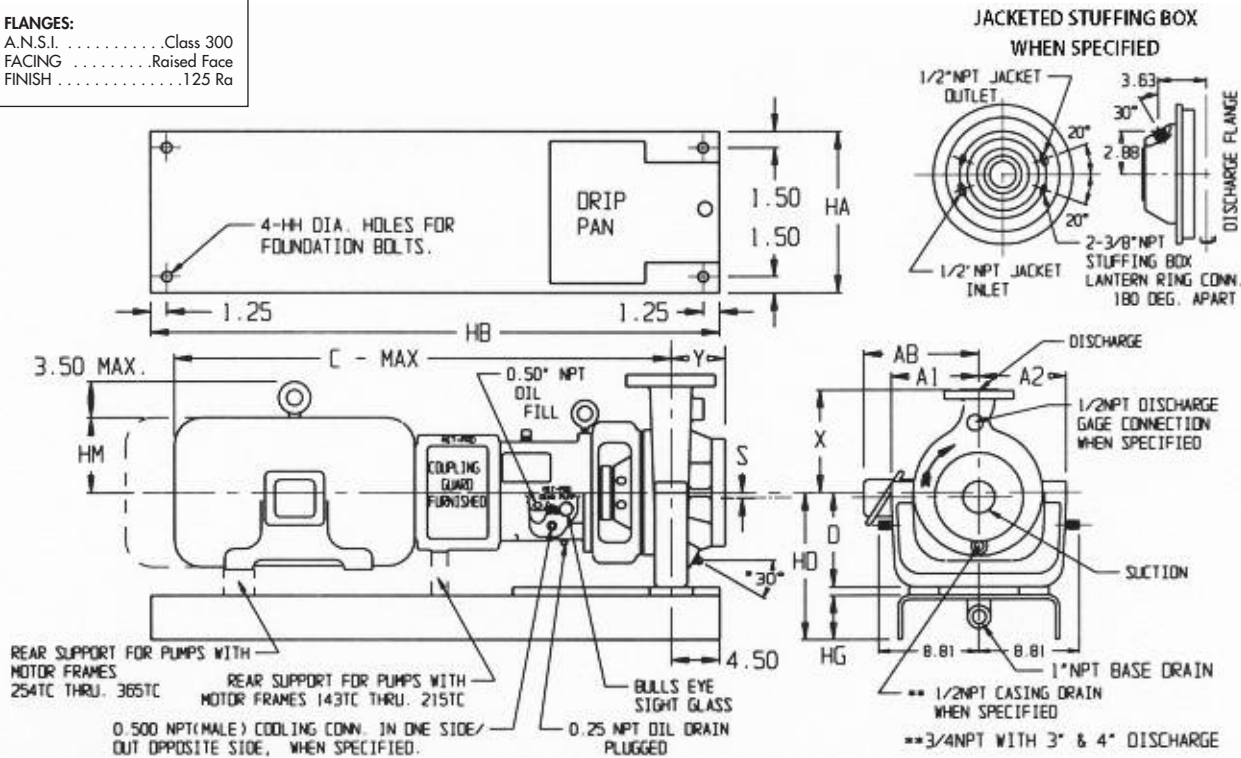

PUMP SIZE	DISCHARGE					SUCTION					A ₁	A ₂	D	S	X	Y
	SIZE	O.D.	THK	B.C.	BOLTS	SIZE	O.D.	THK	B.C.	BOLTS						
*1 x 3 x 8 1/2	1	47/8	11/16	3 1/2	4-5/8	3	8 1/4	1 1/8	6 5/8	8-3/4	8 1/8	8 1/8	8 1/4	0	7 1/2	4
1 1/2 x 3 x 8 1/2	1 1/2	6 1/8	13/16	4 1/2	4-3/4	3	8 1/4	1 1/8	6 5/8	8-3/4	8 1/8	8 1/8	8 1/4	0	8 1/2	4
2 x 3 x 8 1/2	2	6 1/2	7/8	5	8-5/8	3	8 1/4	1 1/8	6 5/8	8-3/4	8 1/8	8 1/8	8 1/4	0	9 1/2	5
*3 x 4 x 8 1/2	3	8 1/4	1 1/8	6 5/8	8-3/4	4	10	1 1/4	7 7/8	8-3/4	9	8 1/8	10	0	11	5
*4 x 6 x 8 1/2	4	10	1 1/4	7 7/8	8-3/4	6	12 1/2	1 7/16	10 5/8	12-3/4	10 1/4	8 1/8	10	5/8	11 1/2	6
1 1/2 x 3 x 10	1 1/2	6 1/8	13/16	4 1/2	4-3/4	3	8 1/4	1 1/8	6 5/8	8-3/4	9	8 3/4	10	0	9	4
2 x 3 x 10	2	6 1/2	7/8	5	8-5/8	3	8 1/4	1 1/8	6 5/8	8-3/4	9	8 3/4	10	0	9 1/2	5
3 x 4 x 10	3	8 1/4	1 1/8	6 5/8	8-3/4	4	10	1 1/4	7 7/8	8-3/4	10 3/8	8 3/4	10	0	11	5
4 x 6 x 10 #2	4	10	1 1/4	7 7/8	8-3/4	6	12 1/2	1 7/16	10 5/8	12-3/4	11 3/4	10	11 1/2	1/8	12 1/2	6
1 x 2 x 11 1/2	1	47/8	11/16	3 1/2	4-5/8	2	6 1/2	7/8	5	8-5/8	9 3/4	9 3/4	10	0	9	5
1 1/2 x 3 x 11 1/2	1 1/2	6 1/8	13/16	4 1/2	4-3/4	3	8 1/4	1 1/8	6 5/8	8-3/4	9 3/4	9 3/4	10	0	10 1/2	4
2 x 3 x 11 1/2	2	6 1/2	7/8	5	8-5/8	3	8 1/4	1 1/8	6 5/8	8-3/4	10 1/4	9 3/4	10	0	10 1/2	5
3 x 4 x 11 1/2	3	8 1/4	1 1/8	6 5/8	8-3/4	4	10	1 1/4	7 7/8	8-3/4	11 1/4	10	11 1/2	0	12 1/2	6
4 x 6 x 11 1/2	4	10	1 1/4	7 7/8	8-3/4	6	12 1/2	1 7/16	10 5/8	12-3/4	11 3/4	10 1/2	11 1/2	3/8	13 1/2	6
1 1/2 x 3 x 13 1/2	1 1/2	6 1/8	13/16	4 1/2	4-3/4	3	8 1/4	1 1/8	6 5/8	8-3/4	11 1/2	11 1/2	11 1/2	0	11	5
2 x 3 x 13 1/2	2	6 1/2	7/8	5	8-5/8	3	8 1/4	1 1/8	6 5/8	8-3/4	11 1/2	11 1/2	11 1/2	0	11 1/2	5
3 x 4 x 13 1/2	3	8 1/4	1 1/8	6 5/8	8-3/4	4	10	1 1/4	7 7/8	8-3/4	12	11 1/2	11 1/2	0	12 1/2	6

All dimensions in inches

FRAME	C	AB	HA	HB	HD			HG	HH	HM
					D=8 1/4	D=10	D=11 1/2			
143TC	35	6 1/2	12	45	12 3/4	14 1/2	16	3 3/4	3/4	37/8
145TC	36	6 1/2	12	45	12 3/4	14 1/2	16	3 3/4	3/4	37/8
182TC	37	7 1/2	12	45	12 3/4	14 1/2	16	3 3/4	3/4	5 1/4
184TC	38	7 1/2	12	45	12 3/4	14 1/2	16	3 3/4	3/4	5 1/4
213TC	42	9 1/2	12	45	12 3/4	14 1/2	16	3 3/4	3/4	6
215TC	43 1/2	9 1/2	12	45	12 3/4	14 1/2	16	3 3/4	3/4	6
254TC	44 1/2	11	15	52	13 1/8	14 7/8	16 3/8	4 1/8	3/4	7
256TC	46	11	15	52	13 1/8	14 7/8	16 3/8	4 1/8	3/4	7

All dimensions in inches

FRAME	C	AB	HA	HB	HD			HG	HH	HM
					D=8 1/4	D=10	D=11 1/2			
284TSC	47 1/2	12 5/8	15	52	13 1/8	14 7/8	16 3/8	4 1/8	3/4	7 3/4
286TSC	49	12 5/8	15	52	13 1/8	14 7/8	16 3/8	4 1/8	3/4	7 3/4
324TSC	49 1/2	14 3/4	18	58	13 3/4	15 1/2	17	4 3/4	1	8 3/4
326TSC	51	14 3/4	18	58	13 3/4	15 1/2	17	4 3/4	1	8 3/4
364TSC	51 1/2	15 5/8	18	58	14	15 1/2	17	4 3/4	1	9 7/8
365TSC	52 1/2	15 5/8	18	58	14	15 1/2	17	4 3/4	1	9 7/8

** 3/4 NPT with 3" & 4" discharge

IMPORTANT: DO NOT USE FOR CONSTRUCTION UNLESS CERTIFIED.

DIMENSION DWG.
NO. R-1029

**STANDARD, END SUCTION, CLOSED IMPELLER, CENTRIFUGAL PROCESS PUMP
TYPE R4170 WITH PEDESTAL FEET**

FLANGES:
A.N.S.I. Class 300
FACING Raised Face
FINISH 125 Ra

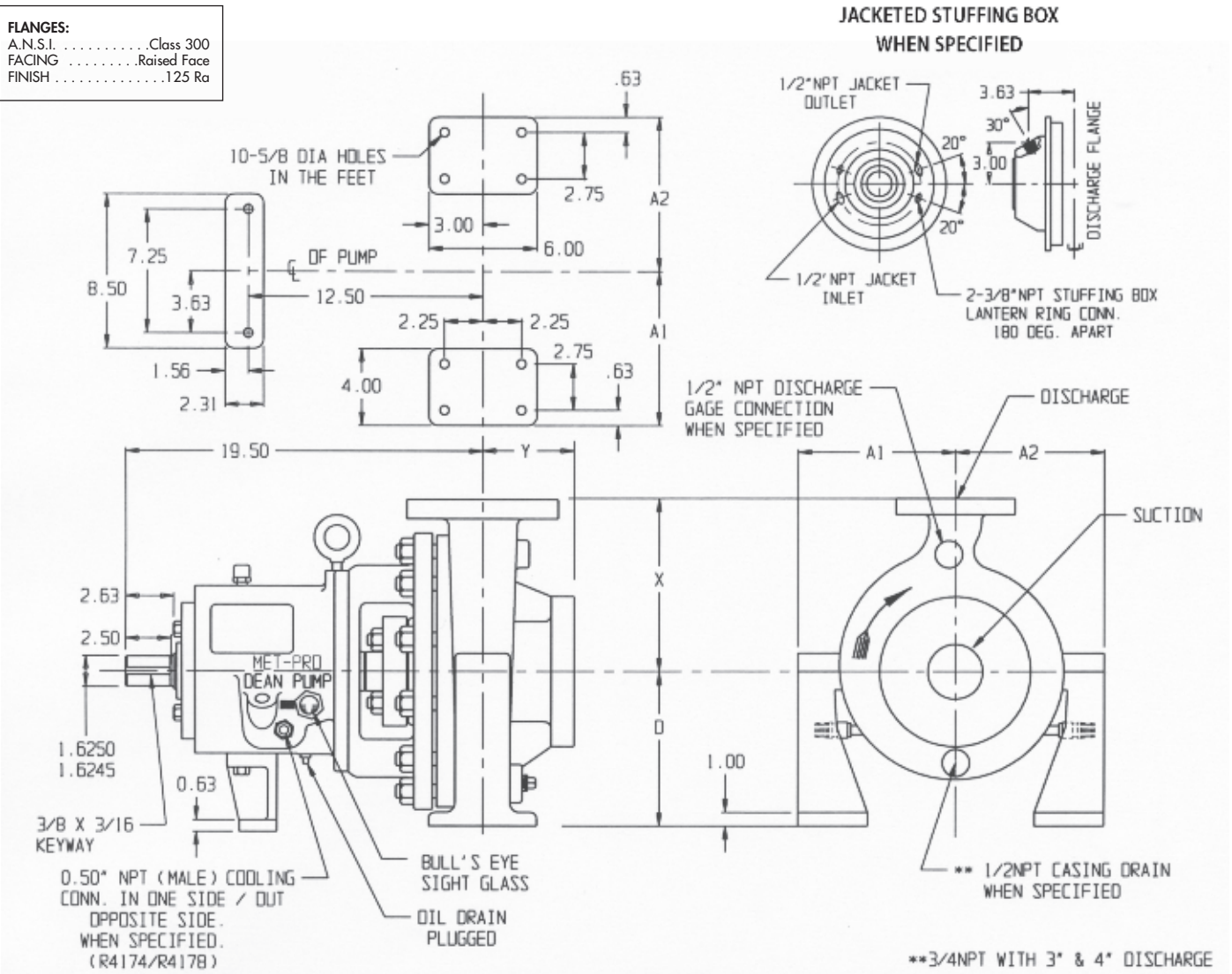

** 3/4 NPT with 3" discharge

PUMP SIZE	DISCHARGE					SUCTION					A ₁	A ₂	D	X	Y
	SIZE	O.D.	THK	B.C.	BOLTS	SIZE	O.D.	THK	B.C.	BOLTS					
1 1/2 x 3 x 13 1/2	1 1/2	6 1/8	13/16	4 1/2	4-3/4	3	8 1/4	1 1/8	6 5/8	8-3/4	11 1/2	11 1/2	11 1/2	11	5
2 x 3 x 13 1/2	2	6 1/2	7/8	5	8-5/8	3	8 1/4	1 1/8	6 5/8	8-3/4	11 1/2	11 1/2	11 1/2	11 1/2	5
3 x 4 x 13 1/2	3	8 1/4	1 1/8	6 5/8	8-3/4	4	10	1 1/4	7 7/8	8-3/4	12	11 1/2	11 1/2	12 1/2	6

All dimensions in inches

IMPORTANT: DO NOT USE FOR CONSTRUCTION UNLESS CERTIFIED.

**DIMENSION DWG.
NO. R-4005**

(317) 293-2930 • E-mail: info@deanpump.com

STANDARD, END SUCTION, CLOSED IMPELLER, CENTRIFUGAL PROCESS PUMP
TYPE R4170 WITH YOKE FOOT

FLANGES:
A.N.S.I.Class 300
FACINGRaised Face
FINISH125 Ra

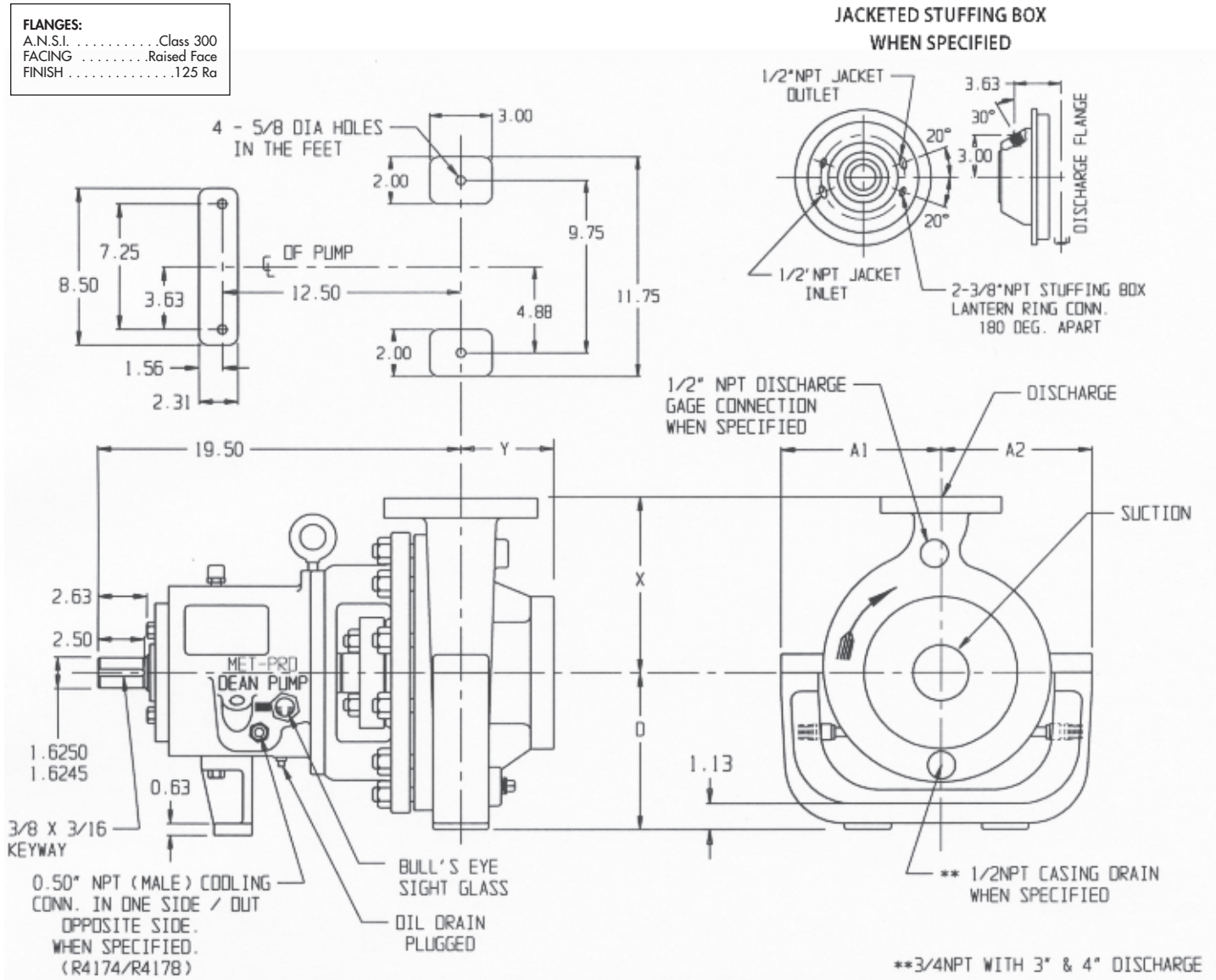

**3/4NPT WITH 3" & 4" DISCHARGE

** 3/4 NPT with 3" discharge

PUMP SIZE	DISCHARGE					SUCTION					A ₁	A ₂	D	X	Y
	SIZE	O.D.	THK	B.C.	BOLTS	SIZE	O.D.	THK	B.C.	BOLTS					
1 1/2 x 3 x 13 1/2	1 1/2	6 1/8	13/16	4 1/2	4-3/4	3	8 1/4	1 1/8	6 5/8	8-3/4	11 1/2	11 1/2	11 1/2	11	5
2 x 3 x 13 1/2	2	6 1/2	7/8	5	8-5/8	3	8 1/4	1 1/8	6 5/8	8-3/4	11 1/2	11 1/2	11 1/2	11 1/2	5
3 x 4 x 13 1/2	3	8 1/4	1 1/8	6 5/8	8-3/4	4	10	1 1/4	7 7/8	8-3/4	12	11 1/2	11 1/2	12 1/2	6

All dimensions in inches

IMPORTANT: DO NOT USE FOR CONSTRUCTION UNLESS CERTIFIED.

DIMENSION DWG.
NO. R-4006

(317) 293-2930 • E-mail: info@deanpump.com

STANDARD, END SUCTION, CLOSED IMPELLER, CENTRIFUGAL PROCESS PUMP
TYPE R4170 WITH REFINERY TYPE BASE

FLANGES:
A.N.S.I. Class 300
FACING Raised Face
FINISH 125 Ra

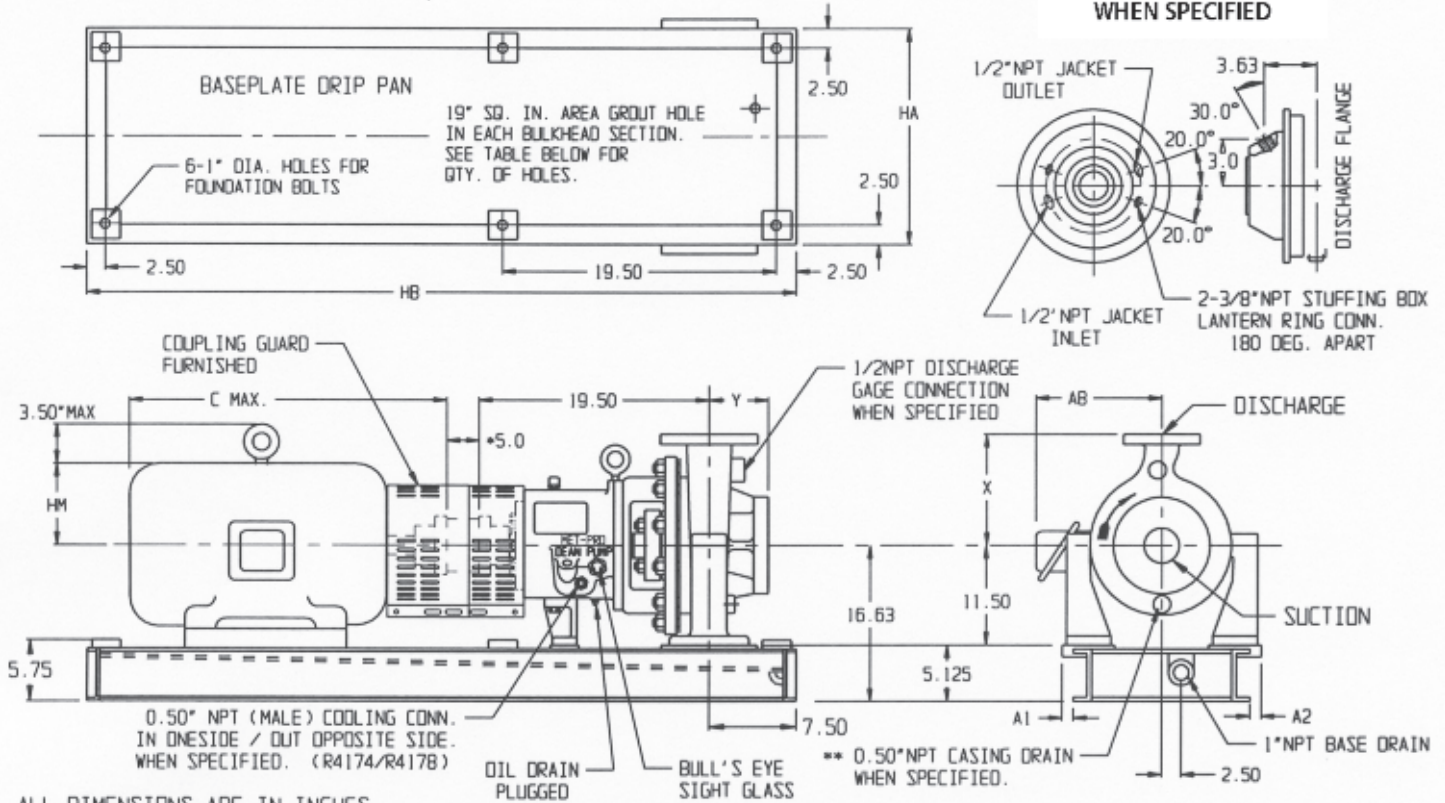

ALL DIMENSIONS ARE IN INCHES

* FOR HORSEPOWER BELOW 40 @ 1750 AND 100 @ 3500 RPM THE SPACER IS 3.50

** 3/4 NPT WITH 3" DISCHARGE

** 3/4 NPT with 3" discharge

PUMP SIZE	DISCHARGE					SUCTION					A ₁	A ₂	X	Y
	SIZE	O.D.	THK	B.C.	BOLTS	SIZE	O.D.	THK	B.C.	BOLTS				
1 1/2 x 3 x 13 1/2	1 1/2	6 1/8	13/16	4 1/2	4-3/4	3	8 1/4	1 1/8	6 5/8	8-3/4	1	1/4	11	5
2 x 3 x 13 1/2	2	6 1/2	7/8	5	8-5/8	3	8 1/4	1 1/8	6 5/8	8-3/4	1	1/4	11 1/2	5
3 x 4 x 13 1/2	3	8 1/4	1 1/8	6 5/8	8-3/4	4	10	1 1/4	7 7/8	8-3/4	1	1/4	12 1/2	6

All dimensions in inches

* For Horsepower below 40 @ 1750 and 100 @ 3500 RPM the spacer is 3 1/2".

FRAME	C	AB	HA	HB	HM	Qty. of GROUT HOLES	FRAME	C	AB	HA	HB	HM	Qty. of GROUT HOLES
254T	22 7/8	11	23	58	7	4	326T	31 1/4	14 3/4	23	62	8 3/4	4
256T	24 3/4	11	23	58	7	4	326TS	29 3/4	14 3/4	23	62	8 3/4	4
284T	26 3/4	12 3/4	23	58	7 3/4	4	364TS	31 1/4	16 1/4	23	62	9 7/8	4
284TS	25 1/4	12 3/4	23	58	7 3/4	4	365TS	32 1/4	16 1/4	23	62	9 7/8	4
286T	28 1/4	12 3/4	23	58	7 3/4	4	404TS	33 1/2	17 1/2	23	72	10 3/4	4
286TS	26 3/4	12 3/4	23	58	7 3/4	4	405TS	35	17 1/2	23	72	10 3/4	4
324T	29 3/4	14 3/4	23	62	8 3/4	4	444TS	38 1/2	18 1/2	26	76	12 1/4	5
324TS	28 1/4	14 3/4	23	62	8 1/4	4	445TS	40 1/2	18 1/2	26	76	12 1/4	5

IMPORTANT: DO NOT USE FOR CONSTRUCTION UNLESS CERTIFIED.

DIMENSION DWG.
NO. R-4040

(317) 293-2930 • E-mail: info@deanpump.com

STANDARD, END SUCTION, CLOSED IMPELLER, CENTRIFUGAL PROCESS PUMP
TYPE R4170 WITH BENT STEEL BASE

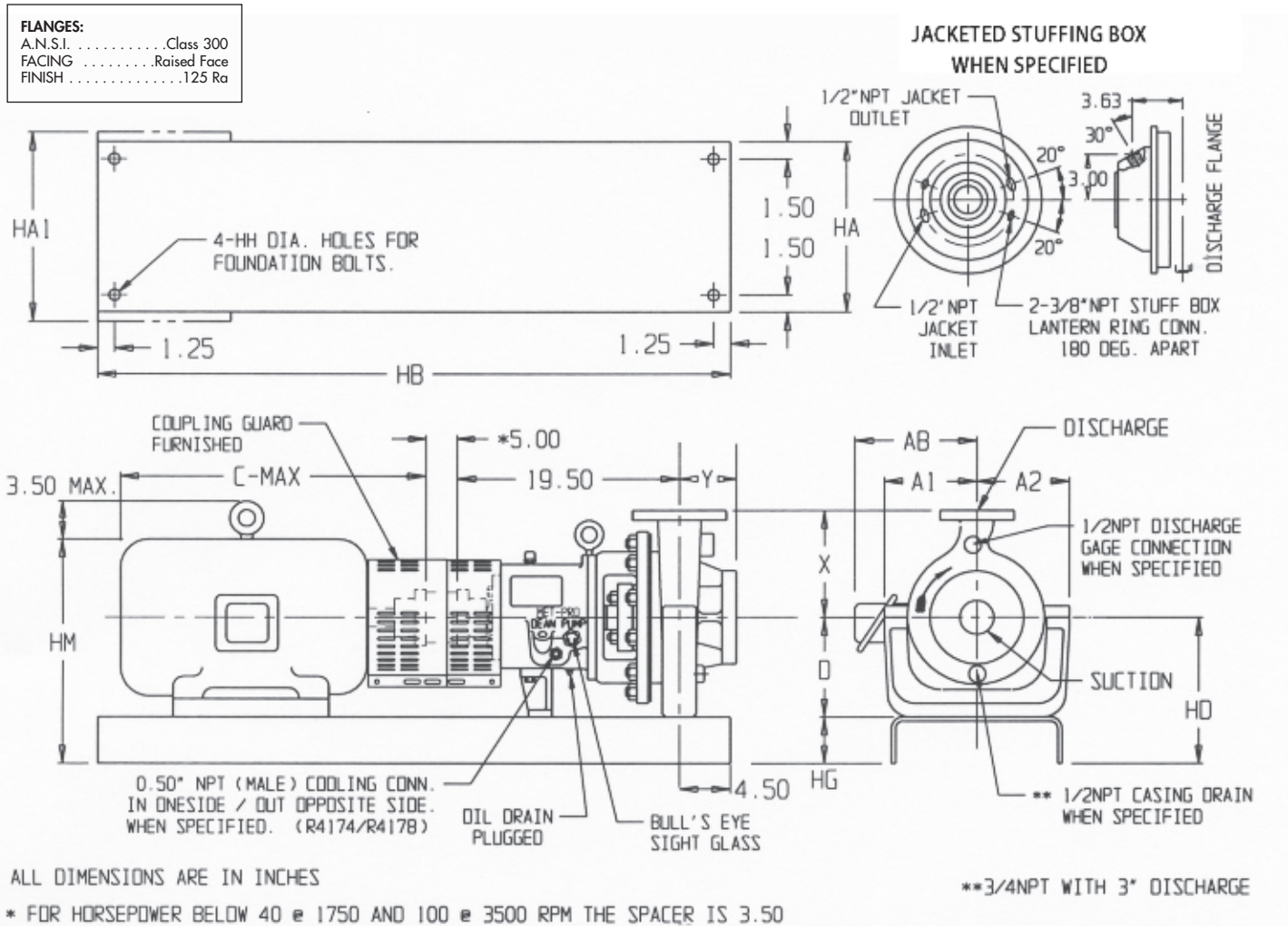

** 3/4" NPT with 3" discharge

PUMP SIZE	DISCHARGE					SUCTION					A ₁	A ₂	D	X	Y
	SIZE	O.D.	THK	B.C.	BOLTS	SIZE	O.D.	THK	B.C.	BOLTS					
1 1/2 x 3 x 13 1/2	1 1/2	6 1/8	13/16	4 1/2	4-3/4	3	8 1/4	1 1/8	6 5/8	8-3/4	11 1/2	11 1/2	11 1/2	11	5
2 x 3 x 13 1/2	2	6 1/2	7/8	5	8-5/8	3	8 1/4	1 1/8	6 5/8	8-3/4	11 1/2	11 1/2	11 1/2	11 1/2	5
3 x 4 x 13 1/2	3	8 1/4	1 1/8	6 5/8	8-3/4	4	10	1 1/4	7 7/8	8-3/4	12	11 1/2	11 1/2	12 1/2	6

All dimensions in inches

* For Horsepower below 40 @ 1750 and 100 @ 3500 RPM the spacer is 3 1/2".

FRAME	C	AB	HA	HA ₁	HB	HD	HG	HH	HM	FRAME	C	AB	HA	HA ₁	HB	HD	HG	HH	HM
254T	22 7/8	11	15	—	52	15 5/8	4 1/8	3/4	22 5/8	326T	31 1/4	14 3/4	18	—	58	16 1/4	4 3/4	1	25
256T	24 3/4	11	15	—	52	15 5/8	4 1/8	3/4	22 5/8	326TS	29 3/4	14 3/4	18	—	58	16 1/4	4 3/4	1	25
284T	26 3/4	12 3/4	15	—	52	15 5/8	4 1/8	3/4	23 3/8	364TS	31 1/4	16 1/4	18	—	58	16 1/4	4 3/4	1	26 1/8
284TS	25 1/4	12 3/4	15	—	52	15 5/8	4 1/8	3/4	23 3/8	365TS	32 1/4	16 1/4	18	—	58	16 1/4	4 3/4	1	26 1/8
286T	28 1/4	12 3/4	15	—	52	15 5/8	4 1/8	3/4	23 3/8	404TS	33 1/2	17 1/2	18	20	60	16 1/8	4 5/8	1	26 7/8
286TS	26 3/4	12 3/4	15	—	52	15 5/8	4 1/8	3/4	23 3/8	405TS	35	17 1/2	18	20	60	16 1/8	4 5/8	1	26 7/8
324T	29 3/4	14 3/4	18	—	58	16 1/4	4 3/4	1	25	444TS	38 1/2	18 1/2	18	22	62	16 3/4	4 3/4	1	29
324TS	28 1/4	14 3/4	18	—	58	16 1/4	4 3/4	1	25	445TS	40 1/2	18 1/2	18	22	62	16 3/4	4 3/4	1	29

IMPORTANT: DO NOT USE FOR CONSTRUCTION UNLESS CERTIFIED.

DIMENSION DWG.
NO. R-4025

STANDARD, END SUCTION, CLOSED IMPELLER, CENTRIFUGAL PROCESS PUMP
TYPE R4180

FLANGES:
A.N.S.I.Class 300
FACINGRaised Face
FINISH125 Ra

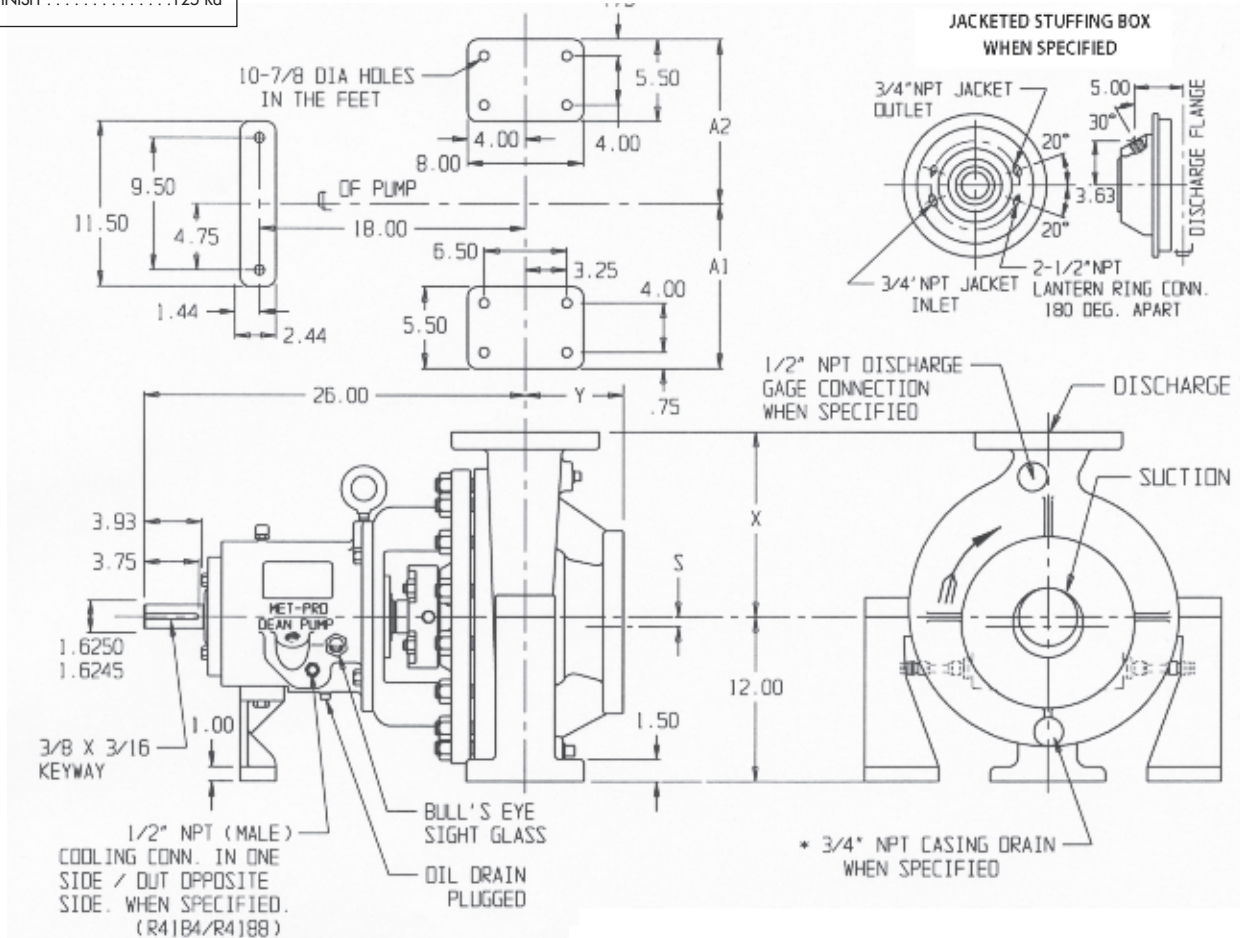

* 1/2 NPT with 2" discharge

PUMP SIZE	DISCHARGE					SUCTION					A ₁	A ₂	S	X	Y
	SIZE	O.D.	THK	B.C.	BOLTS	SIZE	O.D.	THK	B.C.	BOLTS					
4 x 6 x 10 #1	4	10	1 1/4	77/8	8-3/4	6	12 1/2	17/16	10 5/8	12-3/4	12 1/4	10 1/2	1/4	12	6
6 x 8 x 12 1/2	6	12 1/2	17/16	10 5/8	12-3/4	8	15	15/8	13	12-7/8	16 1/4	13	0	16 1/2	7
2 x 4 x 15 1/2	2	6 1/2	7/8	5	8-5/8	4	10	1 1/4	77/8	8-3/4	13 1/2	13 1/2	0	12 1/2	6
3 x 4 x 15 1/2	3	8 1/4	1 1/8	6 5/8	8-3/4	4	10	1 1/4	77/8	8-3/4	13 3/4	13 1/2	0	14	6
4 x 6 x 15 1/2	4	10	1 1/4	77/8	8-3/4	6	12 1/2	17/16	10 5/8	12-3/4	15 3/4	13 1/2	0	16	6

All dimensions in inches

IMPORTANT: DO NOT USE FOR CONSTRUCTION UNLESS CERTIFIED.

DIMENSION DWG.
NO. R-2005

(317) 293-2930 • E-mail: info@deanpump.com

STANDARD, END SUCTION, CLOSED IMPELLER, CENTRIFUGAL PROCESS PUMP
TYPE R4180

FLANGES:
A.N.S.I.Class 300
FACINGRaised Face
FINISH125 Ra

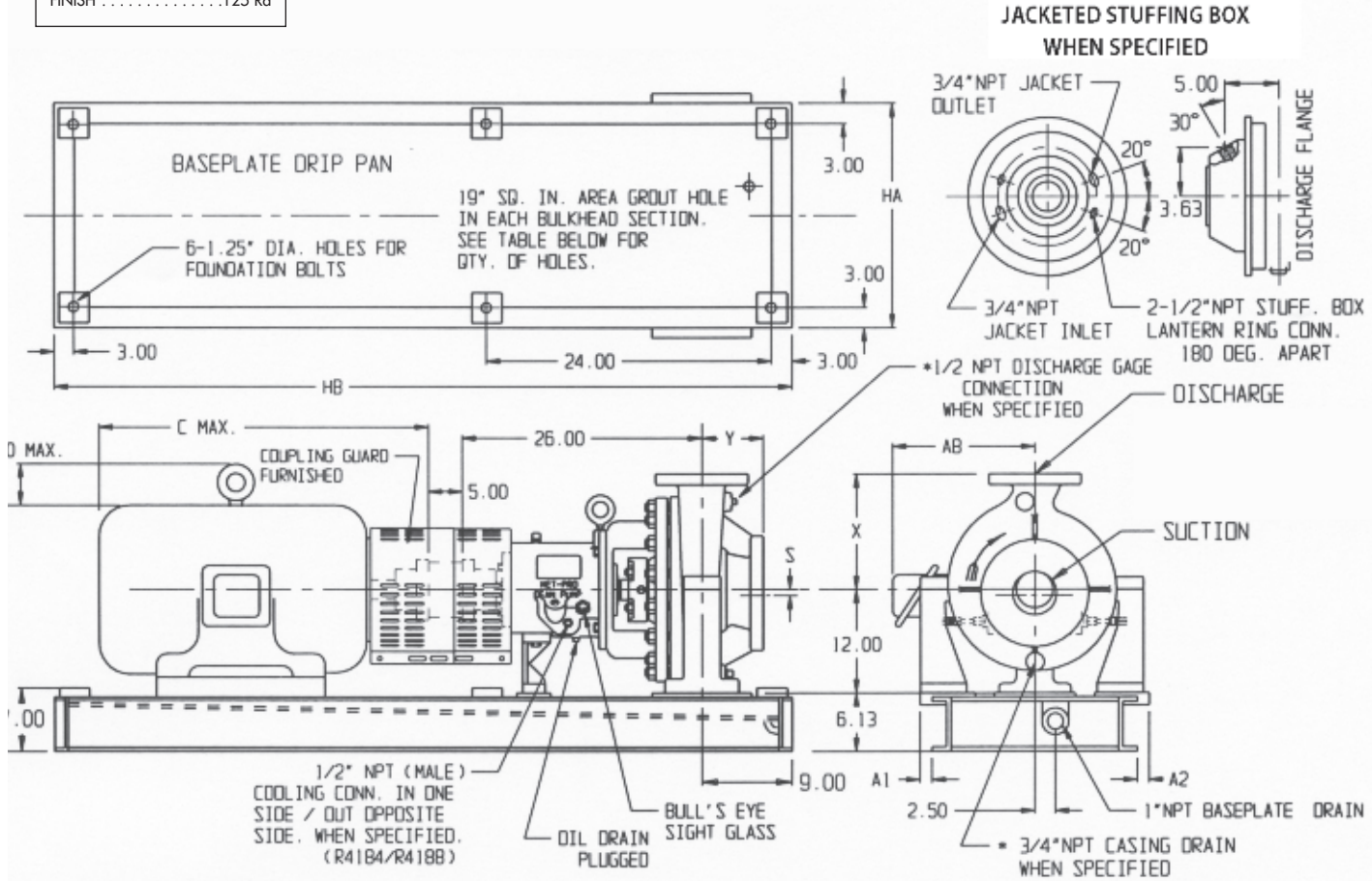

* 1/2 NPT with 2" discharge

PUMP SIZE	DISCHARGE					SUCTION					A ₁	A ₂	S	X	Y
	SIZE	O.D.	THK	B.C.	BOLTS	SIZE	O.D.	THK	B.C.	BOLTS					
4 x 6 x 10 #1	4	10	1 1/4	77/8	8-3/4	6	12 1/2	17/16	10 5/8	12-3/4	0	0	1/4	12	6
6 x 8 x 12 1/2	6	12 1/2	17/16	10 5/8	12-3/4	8	15	1 5/8	13	12-7/8	3/4	0	0	16 1/2	7
2 x 4 x 15 1/2	2	6 1/2	7/8	5	8-5/8	4	10	1 1/4	77/8	8-3/4	3/8	3/8	0	12 1/2	6
3 x 4 x 15 1/2	3	8 1/4	1 1/8	6 5/8	8-3/4	4	10	1 1/4	77/8	8-3/4	3/8	3/8	0	14	6
4 x 6 x 15 1/2	4	10	1 1/4	77/8	8-3/4	6	12 1/2	17/16	10 5/8	12-3/4	3/4	0	0	16	6

All dimensions in inches

FRAME	C	AB	HA			HB	HM	QTY. OF GROUT HOLES
			4x6x10 #1	2x4x15 1/2 3x4x15 1/2	6x8x12 1/2 4x6x15 1/2			
254T	227/8	11	26	28	32	68	247/8	3
256T	243/4	11	26	28	32	68	247/8	3
284T	263/4	12 3/4	26	28	32	68	25 5/8	3
286T	28 1/4	12 3/4	26	28	32	68	25 5/8	3
324TS	28 1/4	14 3/4	26	28	32	72	26 5/8	3
324T	29 3/4	14 3/4	26	28	32	72	26 5/8	3
326TS	29 3/4	14 3/4	26	28	32	72	26 5/8	3
326T	31 1/4	14 3/4	26	28	32	72	26 5/8	3
364TS	31 1/4	16 1/4	26	28	32	72	277/8	3

FRAME	C	AB	HA			HB	HM	QTY. OF GROUT HOLES
			4x6x10 #1	2x4x15 1/2 3x4x15 1/2	6x8x12 1/2 4x6x15 1/2			
364T	327/8	16 1/4	26	28	32	72	277/8	3
365TS	32 1/4	16 1/4	26	28	32	72	277/8	3
365T	33 7/8	16 1/4	26	28	32	72	277/8	3
404TS	33 1/2	17 1/2	26	28	32	78	287/8	5
404T	36 1/2	17 1/2	26	28	32	78	287/8	5
405TS	35	17 1/2	26	28	32	78	287/8	5
405T	38	17 1/2	26	28	32	78	287/8	5
444TS	38 1/2	18 1/2	26	28	32	82	30 3/8	5
445TS	40 1/2	18 1/2	26	28	32	82	30 3/8	5

IMPORTANT: DO NOT USE FOR CONSTRUCTION UNLESS CERTIFIED.

DIMENSION DWG.
NO. R-2040

STANDARD, END SUCTION, CLOSED IMPELLER, CENTRIFUGAL PROCESS PUMP
TYPE R4240

FLANGES:
A.N.S.I. Class 300
FACING Raised Face
FINISH 125 Ra

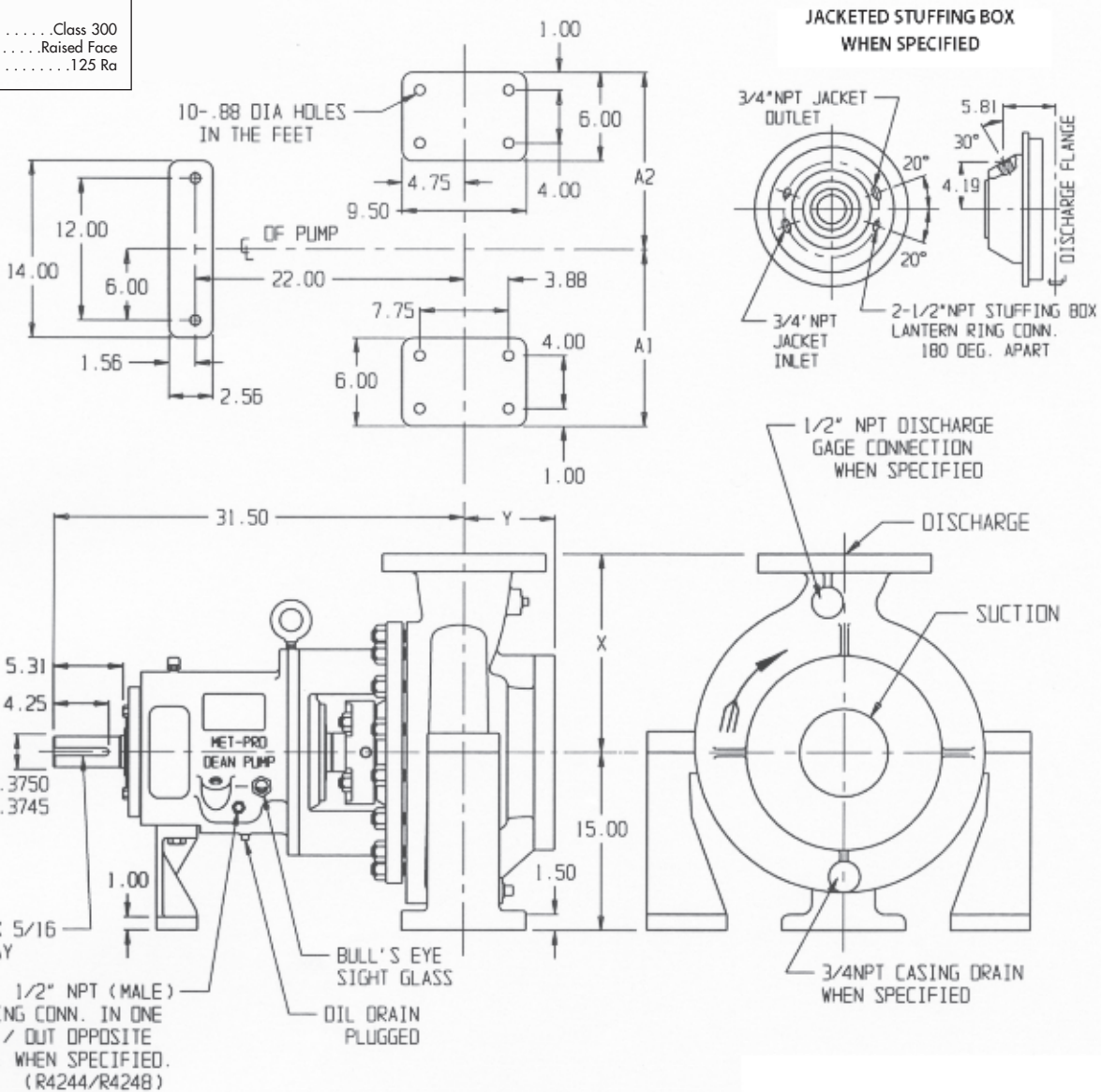

PUMP SIZE	DISCHARGE					SUCTION					A ₁	A ₂	X	Y
	SIZE	O.D.	THK	B.C.	BOLTS	SIZE	O.D.	THK	B.C.	BOLTS				
6 x 8 x 15 1/2	6	12 1/2	17/16	10 5/8	12-3/4	8	15	1 5/8	13	12-7/8	17 3/4	14 1/4	17 1/2	7
8 x 10 x 15 1/2	8	15	1 5/8	13	12-7/8	10	17 1/2	1 7/8	15 1/4	16-1	20	15 1/2	21	8

All dimensions in inches

IMPORTANT: DO NOT USE FOR CONSTRUCTION UNLESS CERTIFIED.

DIMENSION DWG.
NO. R-3005

STANDARD, END SUCTION, CLOSED IMPELLER, CENTRIFUGAL PROCESS PUMP
TYPE R4240

FLANGES:
A.N.S.I. Class 300
FACING Raised Face
FINISH 125 Ra

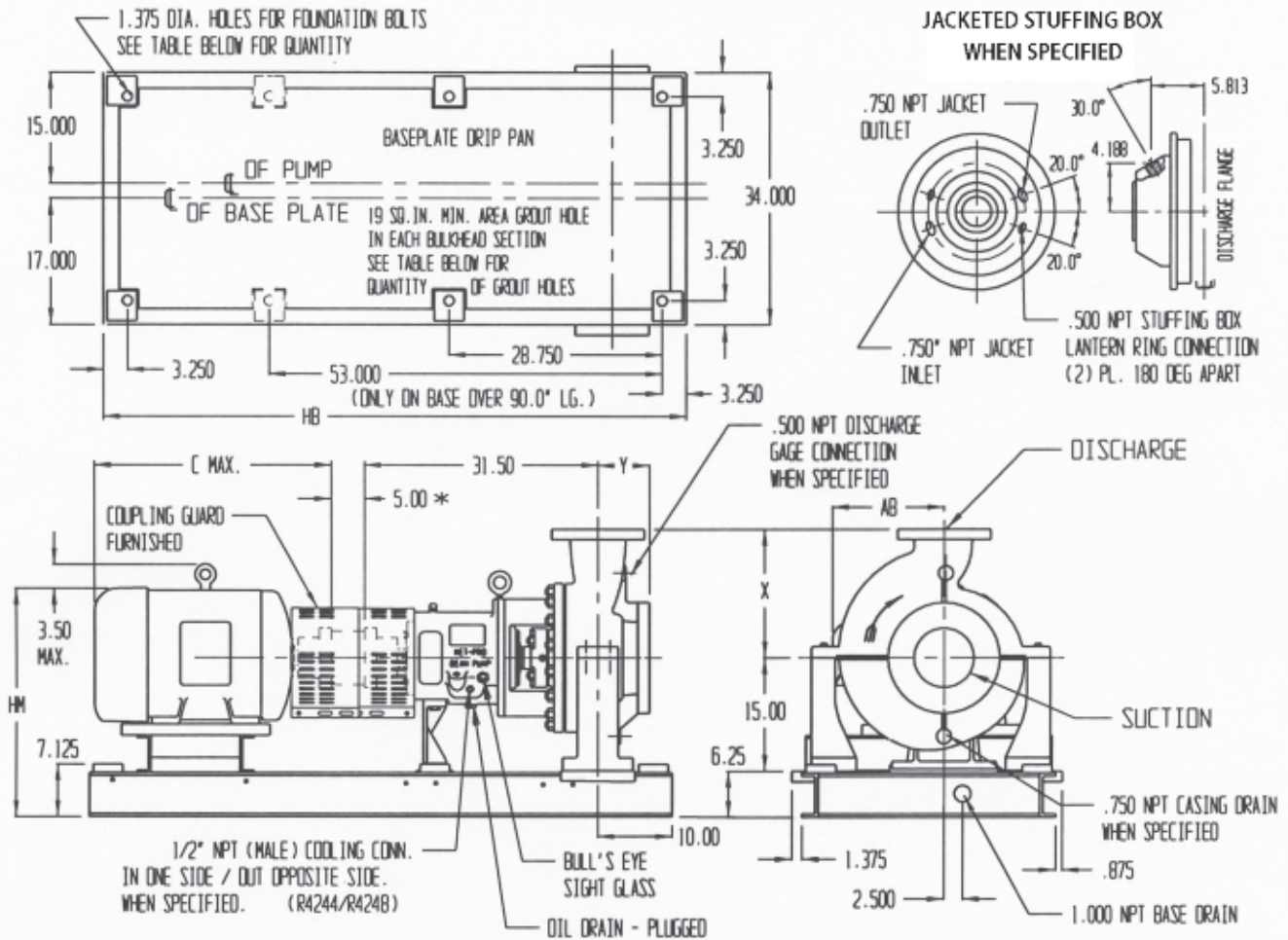

*7 1/4" FOR FALK SPACER ON 444T FRAME AND UP
*7 3/4" FOR WOODS SPACER ON 404T FRAME AND UP

PUMP SIZE	DISCHARGE					SUCTION					X	Y
	SIZE	O.D.	THK	B.C.	BOLTS	SIZE	O.D.	THK	B.C.	BOLTS		
6 x 8 x 15 1/2	6	12 1/2	17 1/16	10 5/8	12-3/4	8	15	1 5/8	13	12-7/8	17 1/2	7
8 x 10 x 15 1/2	8	15	1 5/8	13	12-7/8	10	17 1/2	1 7/8	15 1/4	16-1	21	8

All dimensions in inches

FRAME	C	AB	HB	HM	QTY. OF GROUT HOLES	QTY. OF FOUNDATION BOLT HOLES
254T	22 7/8	11	74	28 1/4	4	6
256T	24 3/4	11	74	28 1/4	4	6
284T	26 3/4	12 3/4	74	29	4	6
286T	28 1/4	12 3/4	74	29	4	6
324T	29 3/4	14 3/4	78	29 3/4	4	6
326T	31 1/2	14 3/4	78	29 3/4	4	6
364T	32 7/8	16 1/4	78	31	4	6
364TS	31 1/4	16 1/4	78	31	4	6
365	33 7/8	16 1/4	78	31	4	6
365TS	32 1/4	16 1/4	78	31	4	6

FRAME	C	AB	HB	HM	QTY. OF GROUT HOLES	QTY. OF FOUNDATION BOLT HOLES
404T	36 1/2	17 1/2	86	32	4	6
404TS	33 1/2	17 1/2	86	32	4	6
405T	38	17 1/2	86	32	4	6
405TS	35	17 1/2	86	32	4	6
444T	42 1/4	18 1/2	92	33 1/2	5	8
444TS	38 1/2	18 1/2	92	33 1/2	5	8
445T	44 3/4	18 1/2	92	33 1/2	5	8
445TS	40 1/2	18 1/2	92	33 1/2	5	8
447T	51	20 1/2	98	33 1/2	5	8
449T	52 3/4	20 1/2	98	33 1/2	5	8

*7 1/4" for Falk Spacer on 444T frame and up

*7 3/4" for Woods Spacer on 404T frame and up

IMPORTANT: DO NOT USE FOR CONSTRUCTION UNLESS CERTIFIED.

DIMENSION DWG.
NO. R-3040

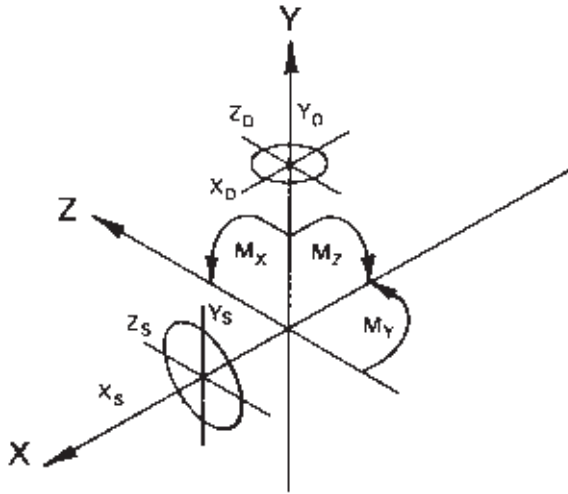

MAXIMUM FORCES ON FLANGES

FOR SUCTION FLANGE

$$\begin{aligned} \pm F_x &\leq 200 \text{ lbs./nom. in.} \leq 1.2W \\ \pm F_y &\leq 130 \text{ lbs./nom. in.} \leq 0.6W \\ \pm F_z &\leq 160 \text{ lbs./nom. in.} \leq 1.0W \\ F_r &= (F_y^2 + F_z^2)^{1/2} \leq 2000 \text{ lbs.} \end{aligned}$$

FOR DISCHARGE FLANGE

$$\begin{aligned} \pm F_x &\leq 1.3W \leq 160 \text{ lbs./nom. in.} \\ -F_y \text{ (Compression)} &\leq 200 \text{ lbs./nom. in.} \leq 1.2W \\ +F_y \text{ (Tension)} &\leq 100 \text{ lbs./nom. in.} \leq 0.5W \\ \pm F_z &\leq 1.0W \leq 130 \text{ lbs./nom. in.} \\ F_r &= (F_x^2 + F_z^2)^{1/2} \leq 2000 \text{ lbs.} \end{aligned}$$

WHERE

- F = Force in pounds
- F_r = Resultant force
- W = Weight of pump only, in pounds

**MAXIMUM MOMENTS APPLIED TO A PUMP ON A FULLY BOLTED AND GROUTED BASEPLATE.
LOADS ARE TO BE APPLIED ONLY THROUGH THE SUCTION AND DISCHARGE FLANGES.**

Pump Size	Type	Wt. - lbs. Pump only	± M _x lb. ft.	± M _y lb. ft.	± M _z lb. ft.
1 x 3 x 8 1/2	R4140	210	690	340	725
1 1/2 x 3 x 8 1/2	R4140	235	690	340	725
2 x 3 x 8 1/2	R4140	260	690	340	725
3 x 4 x 8 1/2	R4140	285	725	295	600
4 x 6 x 8 1/2	R4140	325	785	320	600
1 1/2 x 3 x 10	R4140	255	760	310	600
2 x 3 x 10	R4140	290	760	310	600
3 x 4 x 10	R4140	320	830	340	600
4 x 6 x 10	R4140	360	950	340	600
1 x 2 x 11 1/2	R4140	240	850	350	600
1 1/2 x 3 x 11 1/2	R4140	275	850	350	600
2 x 3 x 11 1/2	R4140	315	870	355	600

Pump Size	Type	Wt. - lbs. Pump only	± M _x lb. ft.	± M _y lb. ft.	± M _z lb. ft.
3 x 4 x 11 1/2	R4140	345	930	335	575
4 x 6 x 11 1/2	R4140	430	980	350	760
1 1/2 x 3 x 13 1/2	R4140/R4170	400	1015	365	525
2 x 3 x 13 1/2	R4140/R4170	414	1015	365	525
3 x 4 x 13 1/2	R4140/R4170	430	1045	375	630
4 x 6 x 10	R4180	480	2300	1850	800
6 x 8 x 12 1/2	R4180	560	2740	1490	800
2 x 4 x 15 1/2	R4180	575	2530	1375	800
3 x 4 x 15 1/2	R4180	587	2550	1385	800
4 x 6 x 15 1/2	R4180	604	2740	1490	800
6 x 8 x 15 1/2	R4240	919	3000	1615	1500
8 x 10 x 15 1/2	R4240	942	3340	1810	1500

Maximum allowable forces and moments calculated from these force equations or the tabulated moment tables are those resulting in a maximum of .010 inch movement of the shaft measured at the shaft coupling when the pump is mounted on its baseplate and that baseplate is fully bolted to a properly designed foundation and is fully grouted in place. For a full discussion see API Standard 610, 5th Edition.

PUMP PERFORMANCE: This curve, based on extensive tests, defines the average performance of this pump for liquids having a viscosity of 70 SSU or less. Actual performance of individual units may differ slightly from the performance indicated on this curve. Pump applications made from the data contained herein are subject to confirmation and acceptance by our Engineering Department at our Indianapolis Office.

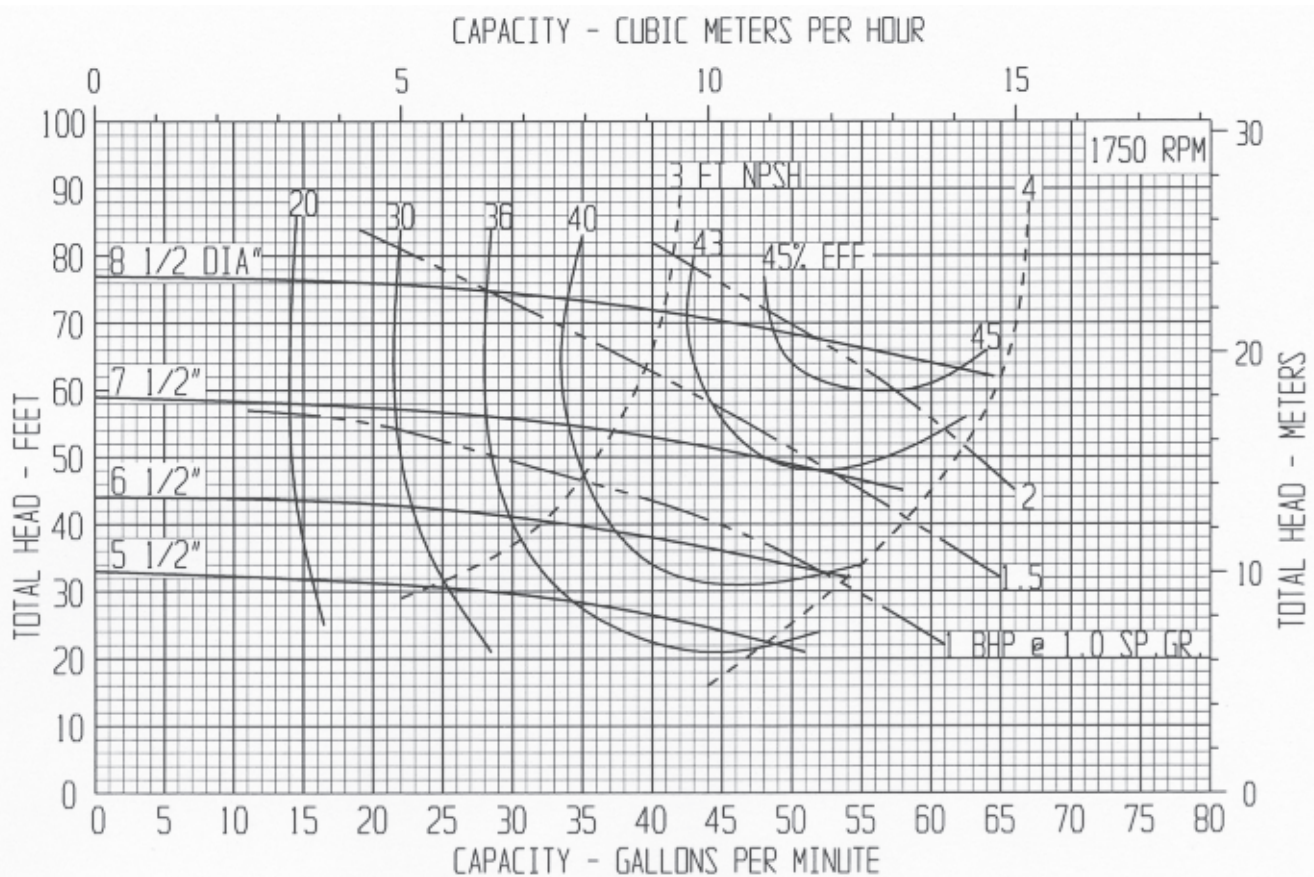
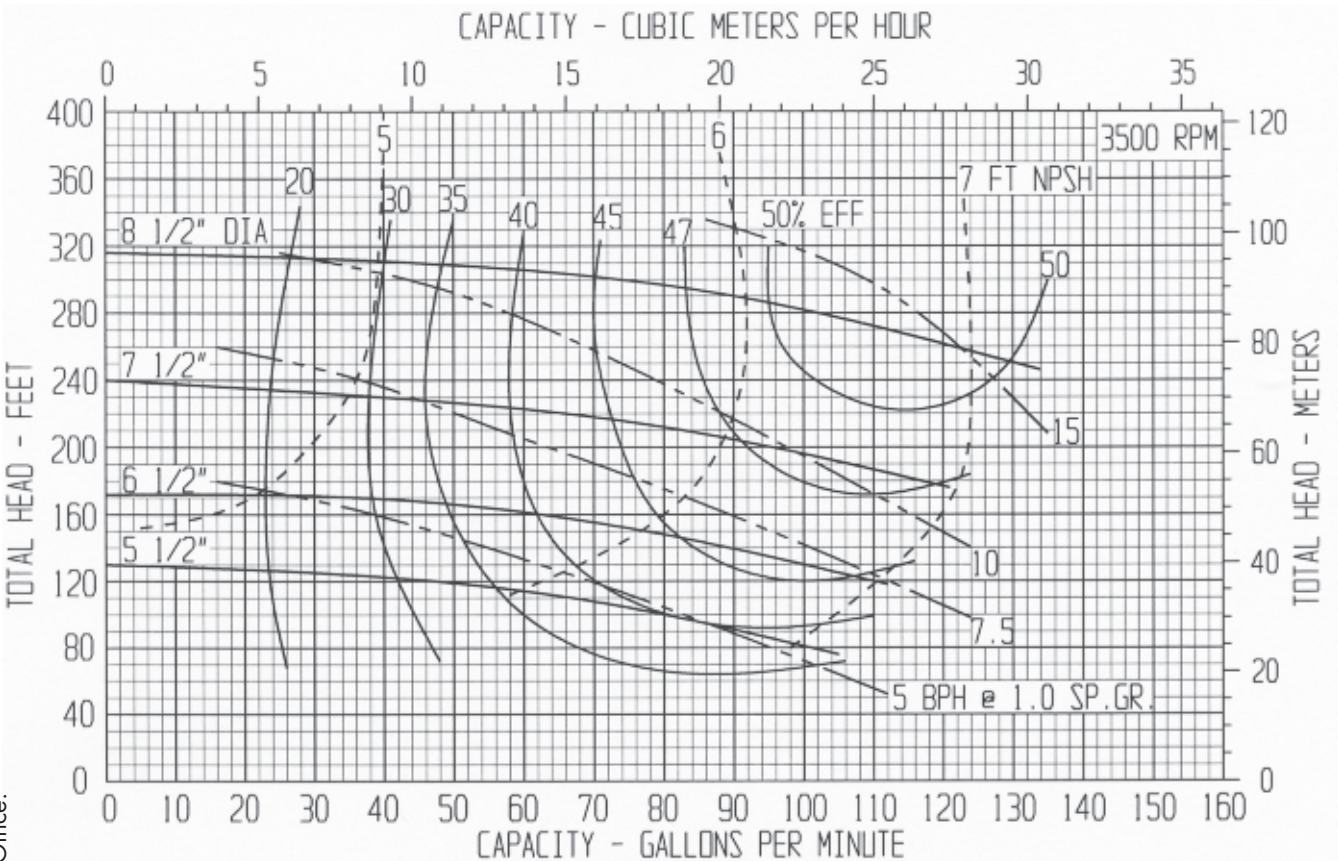

PUMP PERFORMANCE: This curve, based on extensive tests, defines the average performance of this pump for liquids having a viscosity of 70 SSU or less. Actual performance of individual units may differ slightly from the performance indicated on this curve. Pump applications made from the data contained herein are subject to confirmation and acceptance by our Engineering Department at our Indianapolis Office.

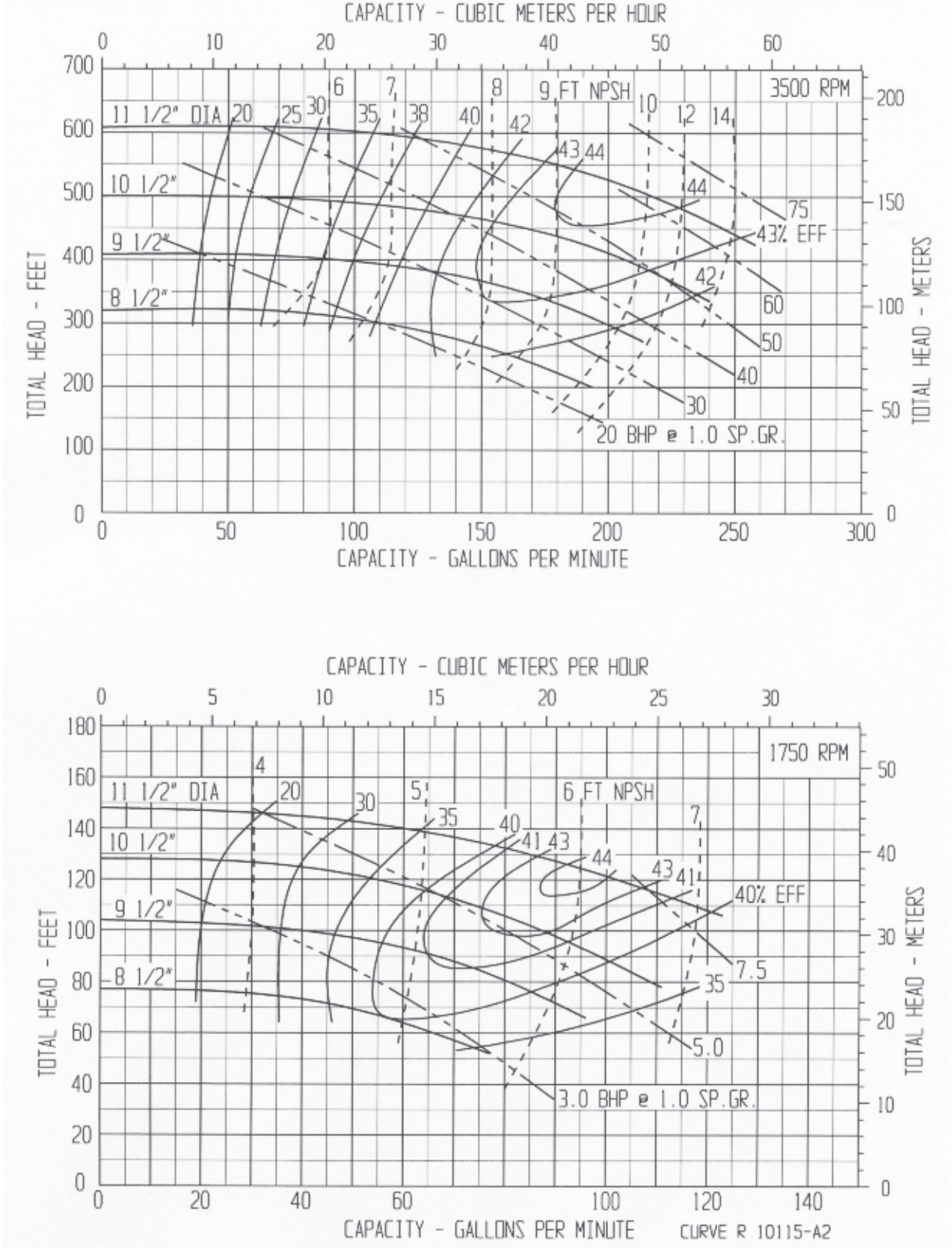

PUMP PERFORMANCE: This curve, based on extensive tests, defines the average performance of this pump for liquids having a viscosity of 70 SSU or less. Actual performance of individual units may differ slightly from the performance indicated on this curve. Pump applications made from the data contained herein are subject to confirmation and acceptance by our Engineering Department at our Indianapolis Office.

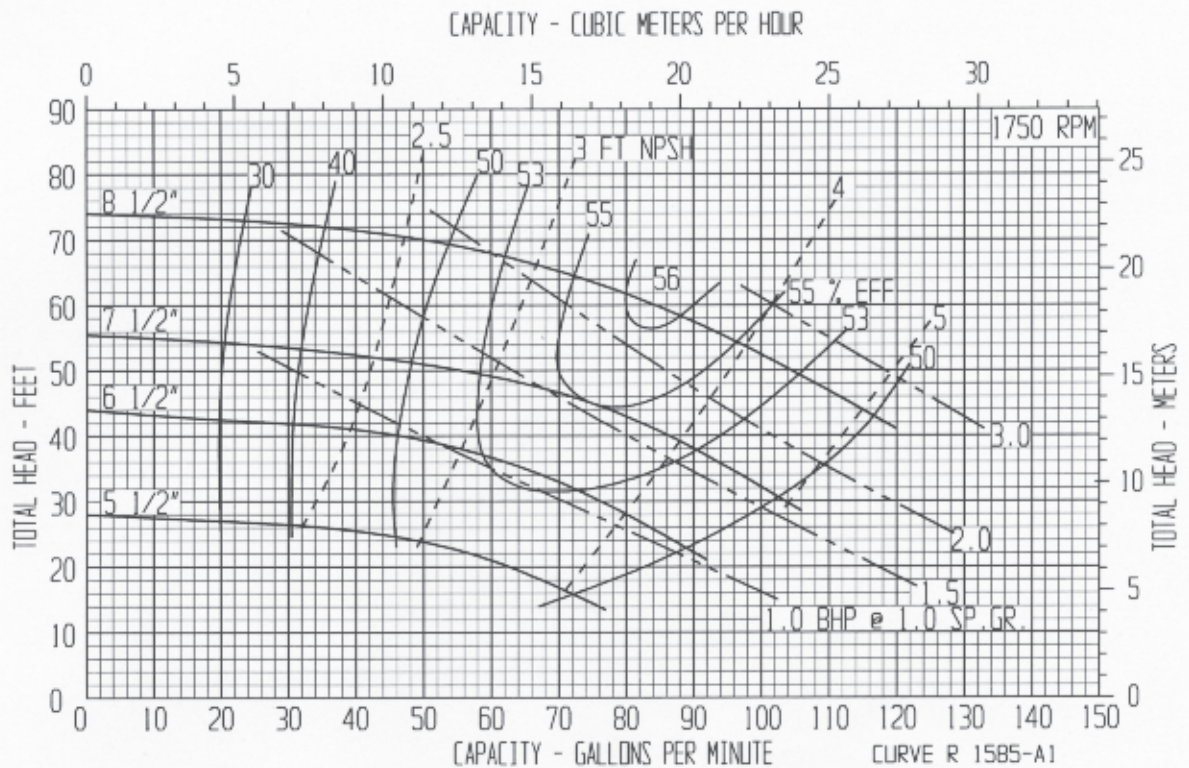
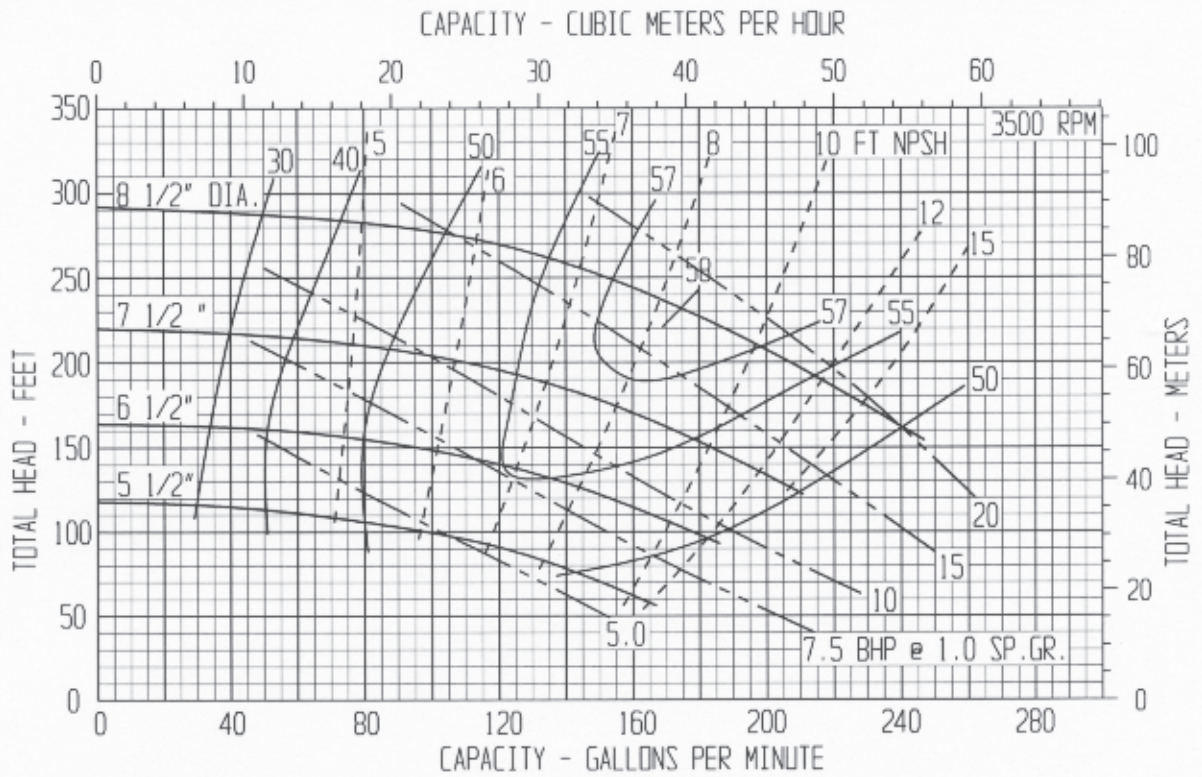

PUMP PERFORMANCE: This curve, based on extensive tests, defines the average performance of this pump for liquids having a viscosity of 70 SSU or less. Actual performance of individual units may differ slightly from the performance indicated on this curve. Pump applications made from the data contained herein are subject to confirmation and acceptance by our Engineering Department at our Indianapolis Office.

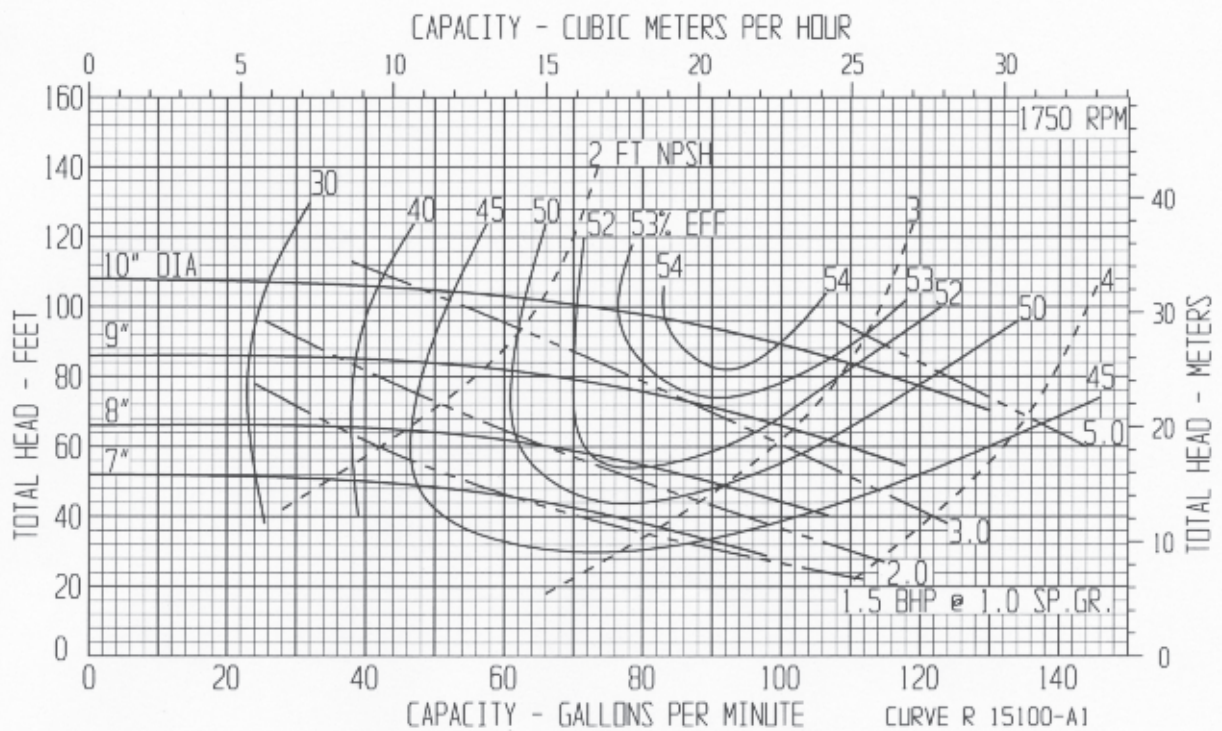
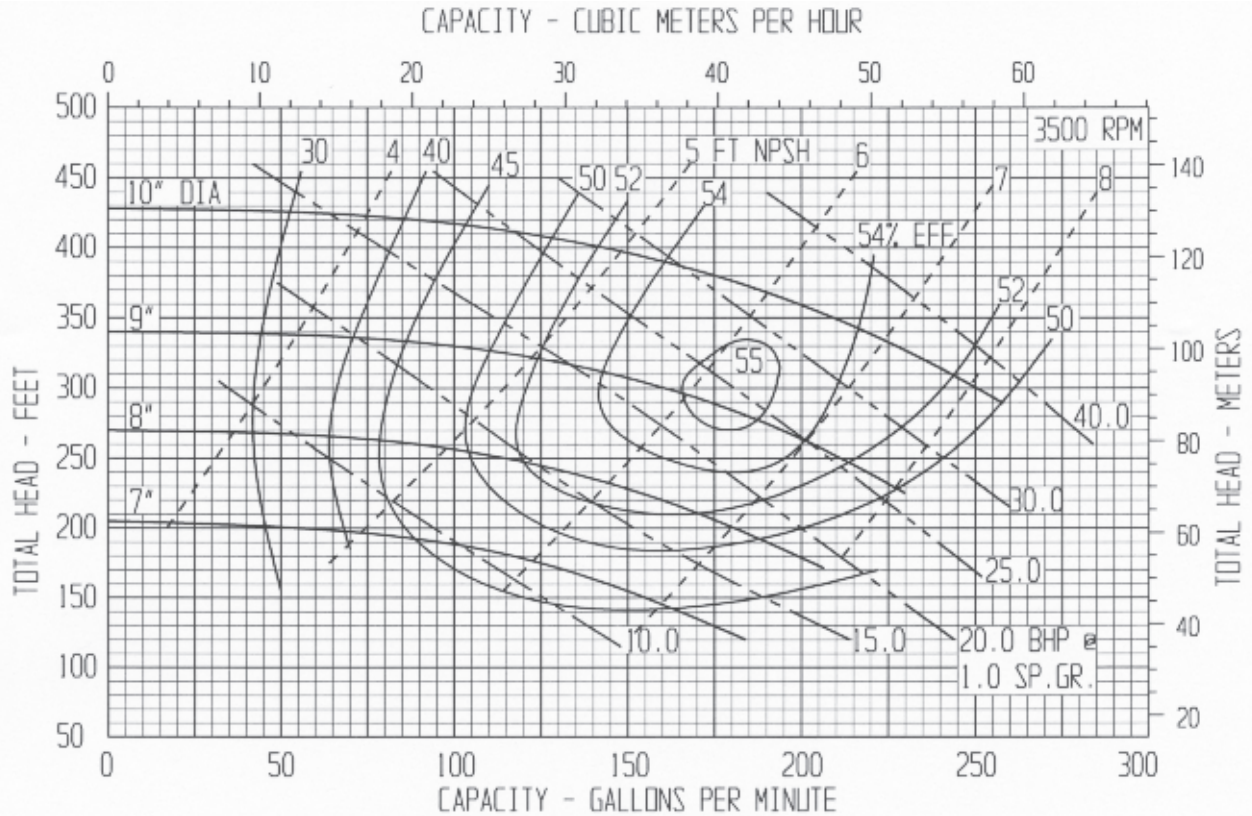

PUMP PERFORMANCE: This curve, based on extensive tests, defines the average performance of this pump for liquids having a viscosity of 70 SSU or less. Actual performance of individual units may differ slightly from the performance indicated on this curve. Pump applications made from the data contained herein are subject to confirmation and acceptance by our Engineering Department at our Indianapolis Office.

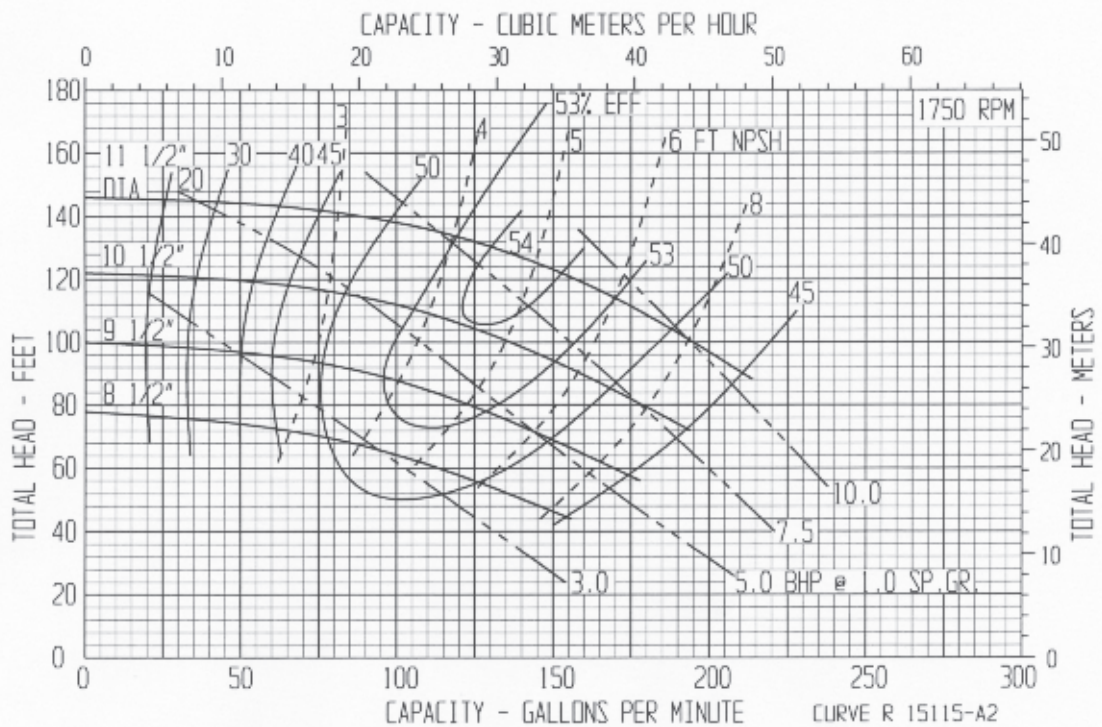
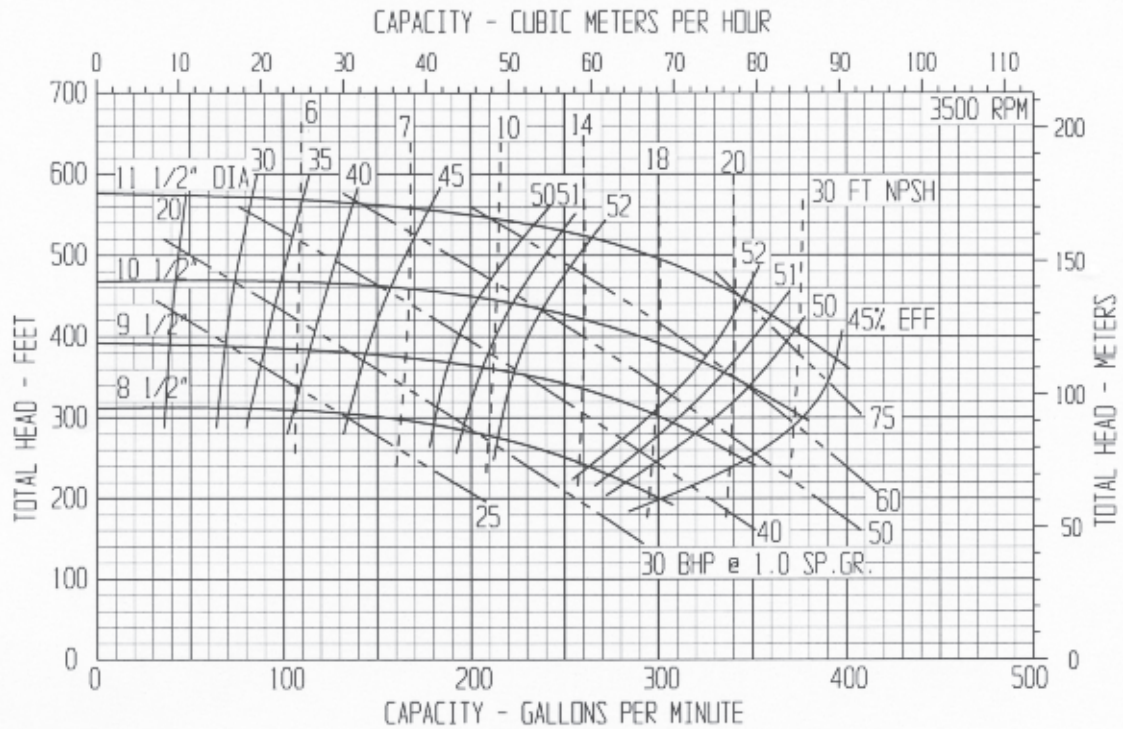

PUMP PERFORMANCE: This curve, based on extensive tests, defines the average performance of this pump for liquids having a viscosity of 70 SSU or less. Actual performance of individual units may differ slightly from the performance indicated on this curve. Pump applications made from the data contained herein are subject to confirmation and acceptance by our Engineering Department at our Indianapolis Office.

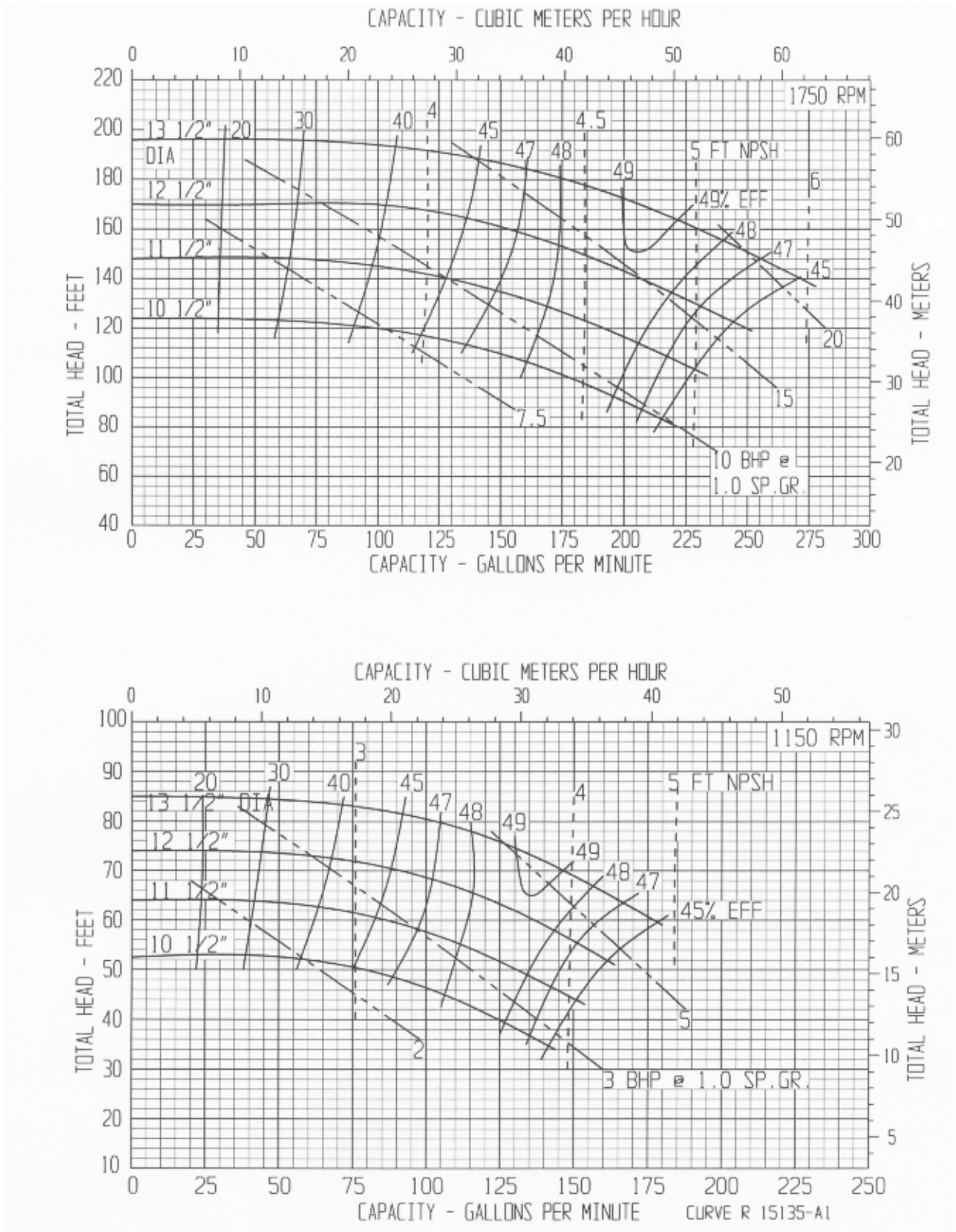

PUMP PERFORMANCE: This curve, based on extensive tests, defines the average performance of this pump for liquids having a viscosity of 70 SSU or less. Actual performance of individual units may differ slightly from the performance indicated on this curve. Pump applications made from the data contained herein are subject to confirmation and acceptance by our Engineering Department at our Indianapolis Office.

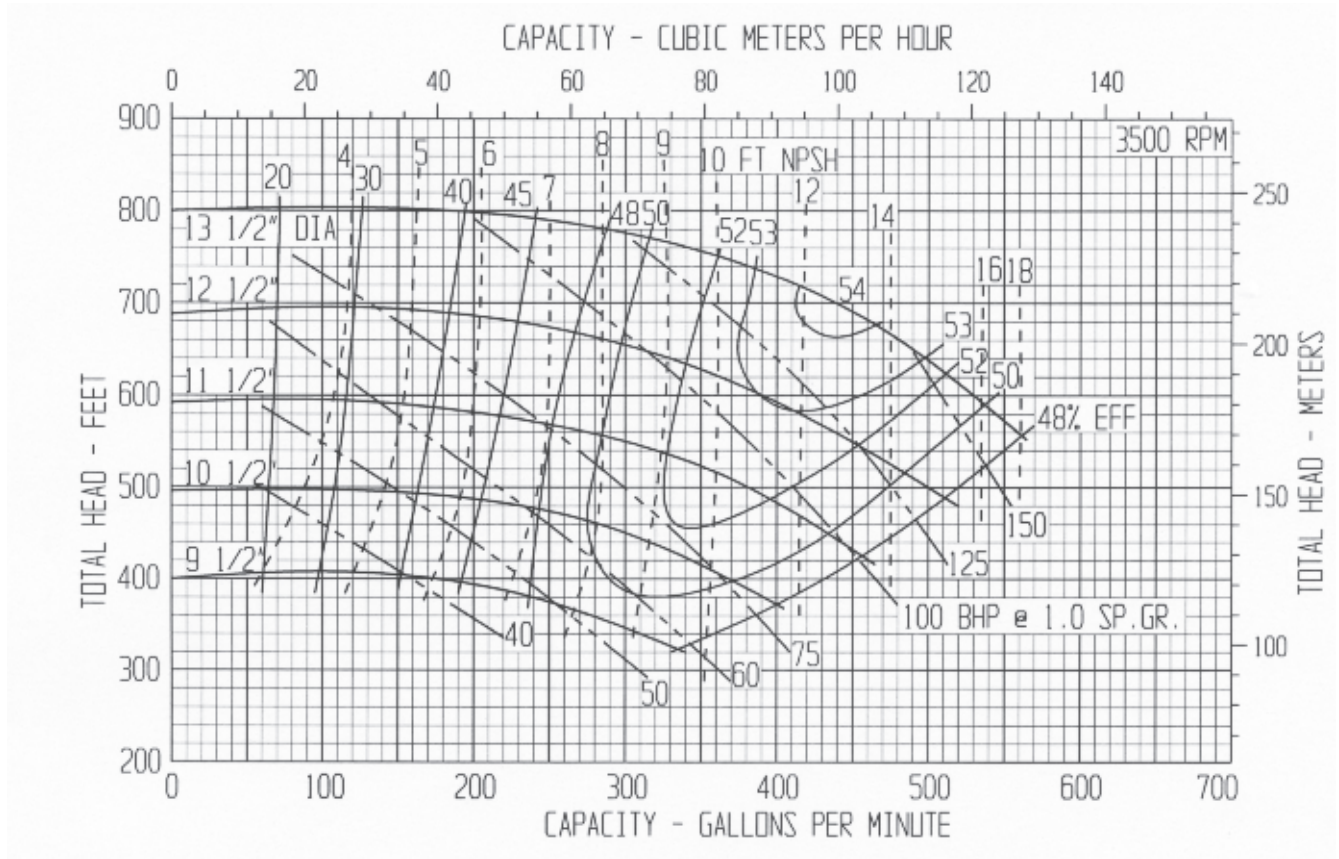

CURVE R 15135-B1

PUMP PERFORMANCE: This curve, based on extensive tests, defines the average performance of this pump for liquids having a viscosity of 70 SSU or less. Actual performance of individual units may differ slightly from the performance indicated on this curve. Pump applications made from the data contained herein are subject to confirmation and acceptance by our Engineering Department at our Indianapolis Office.

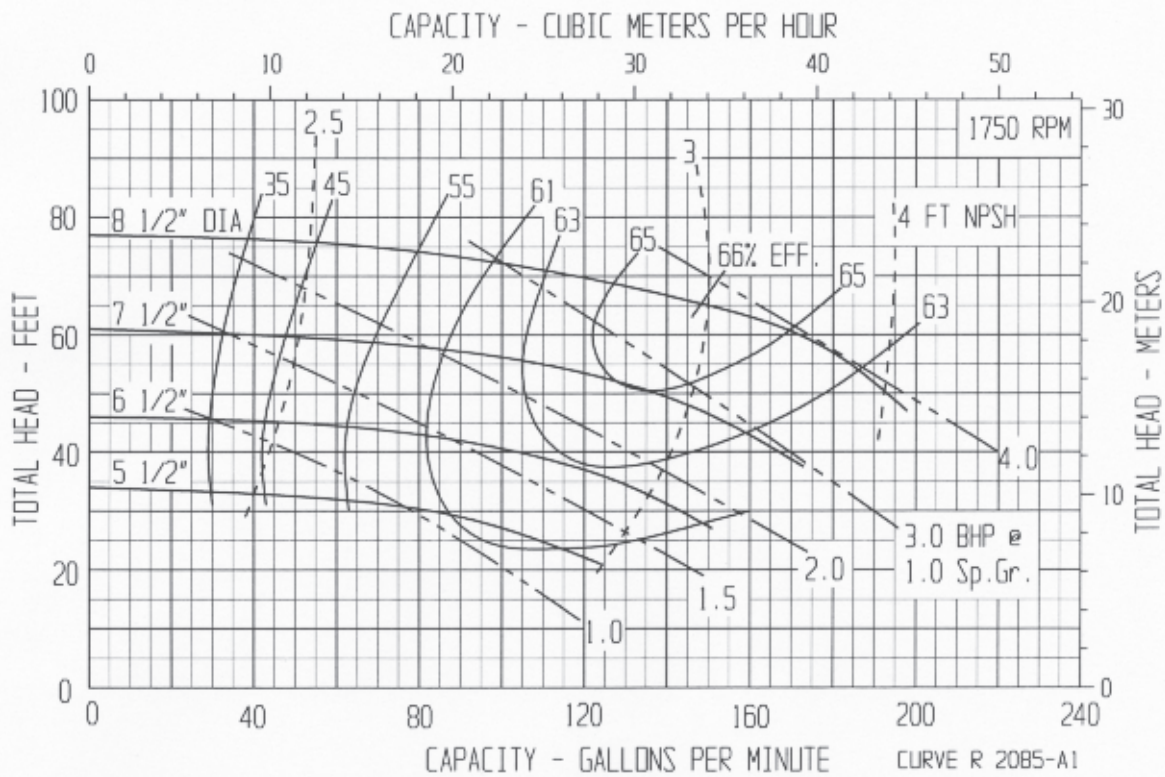
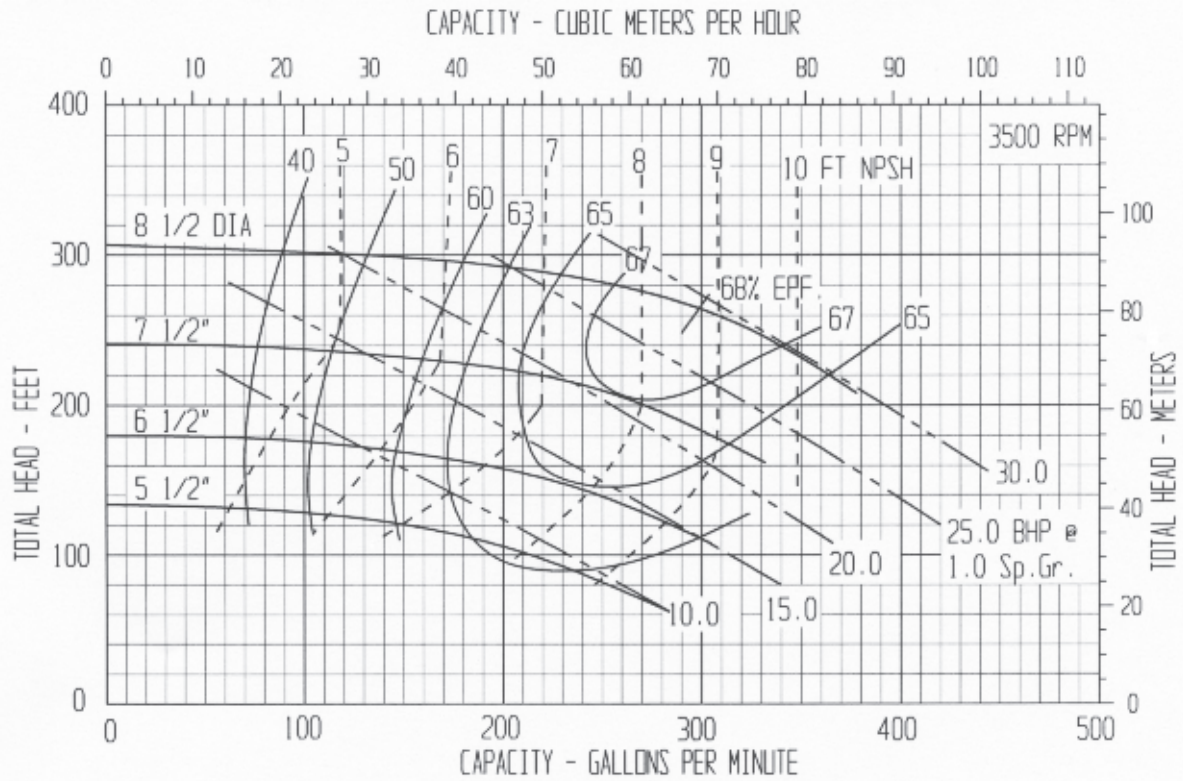

PUMP PERFORMANCE: This curve, based on extensive tests, defines the average performance of this pump for liquids having a viscosity of 70 SSU or less. Actual performance of individual units may differ slightly from the performance indicated on this curve. Pump applications made from the data contained herein are subject to confirmation and acceptance by our Engineering Department at our Indianapolis Office.

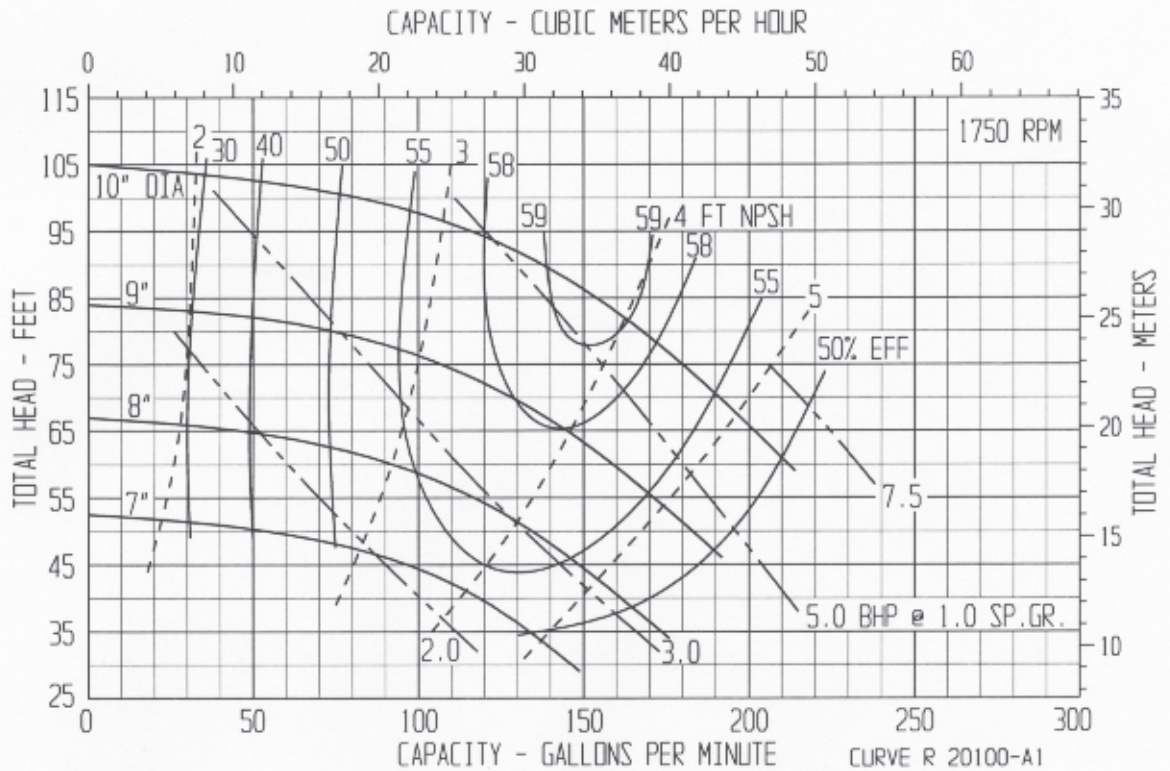
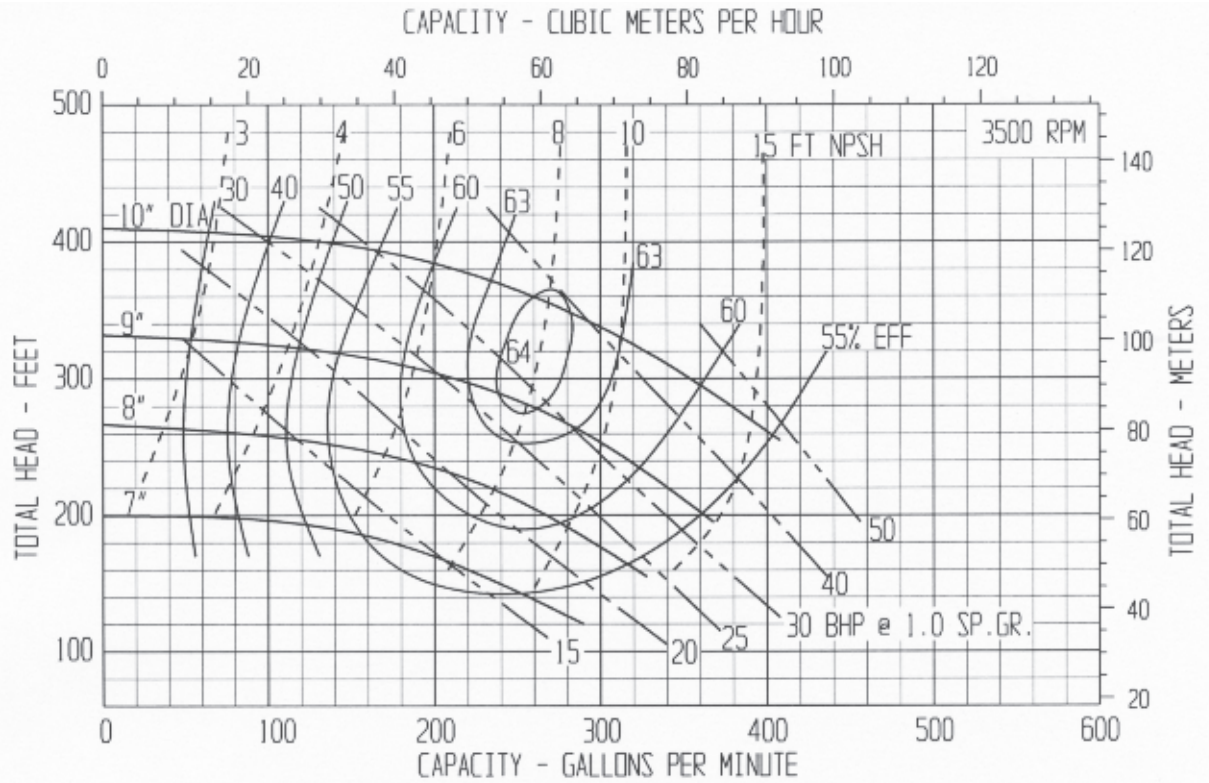

CURVE R 20100-A1

PUMP PERFORMANCE: This curve, based on extensive tests, defines the average performance of this pump for liquids having a viscosity of 70 SSU or less. Actual performance of individual units may differ slightly from the performance indicated on this curve. Pump applications made from the data contained herein are subject to confirmation and acceptance by our Engineering Department at our Indianapolis Office.

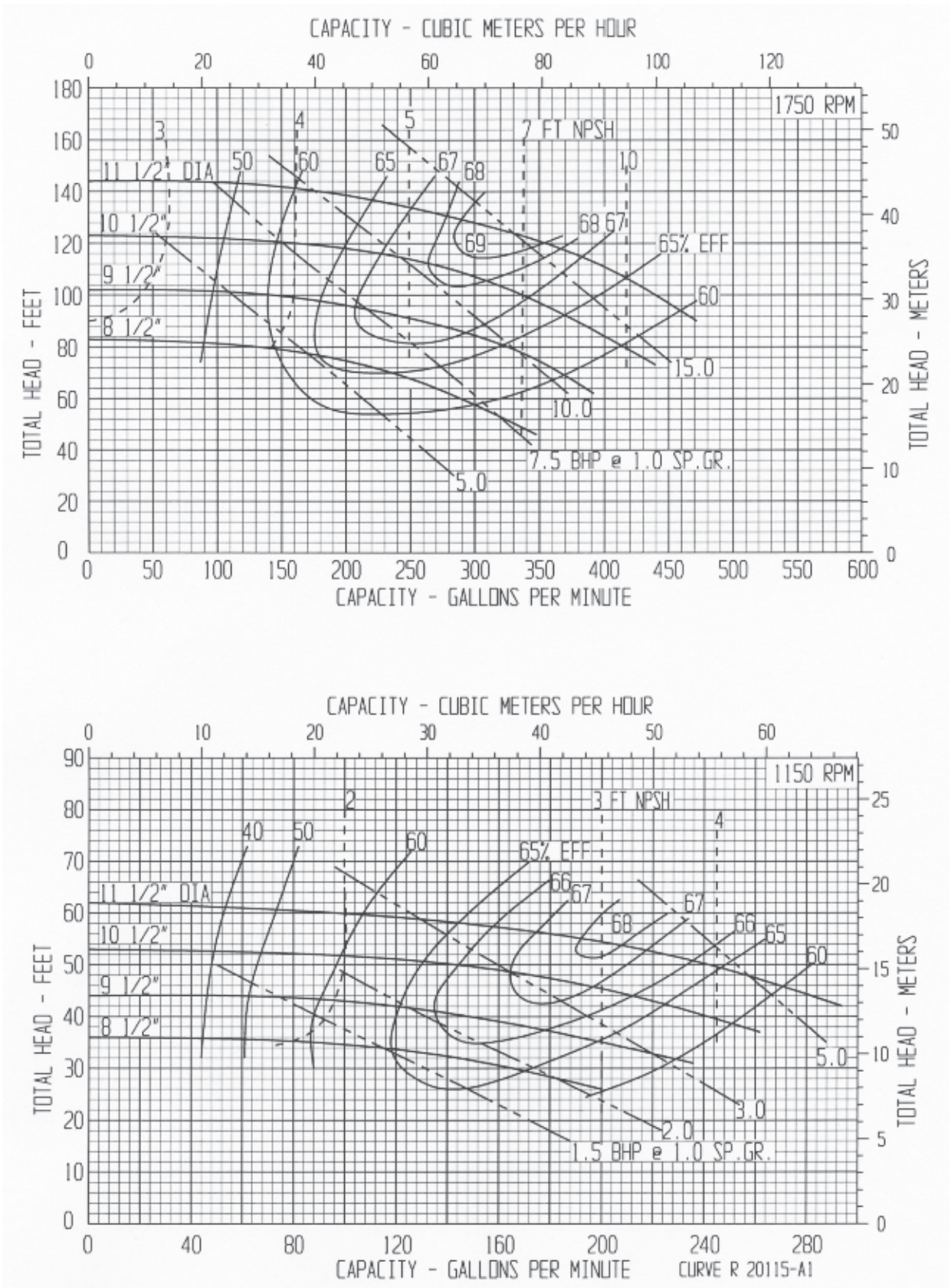

PUMP PERFORMANCE: This curve, based on extensive tests, defines the average performance of this pump for liquids having a viscosity of 70 SSU or less. Actual performance of individual units may differ slightly from the performance indicated on this curve. Pump applications made from the data contained herein are subject to confirmation and acceptance by our Engineering Department at our Indianapolis Office.

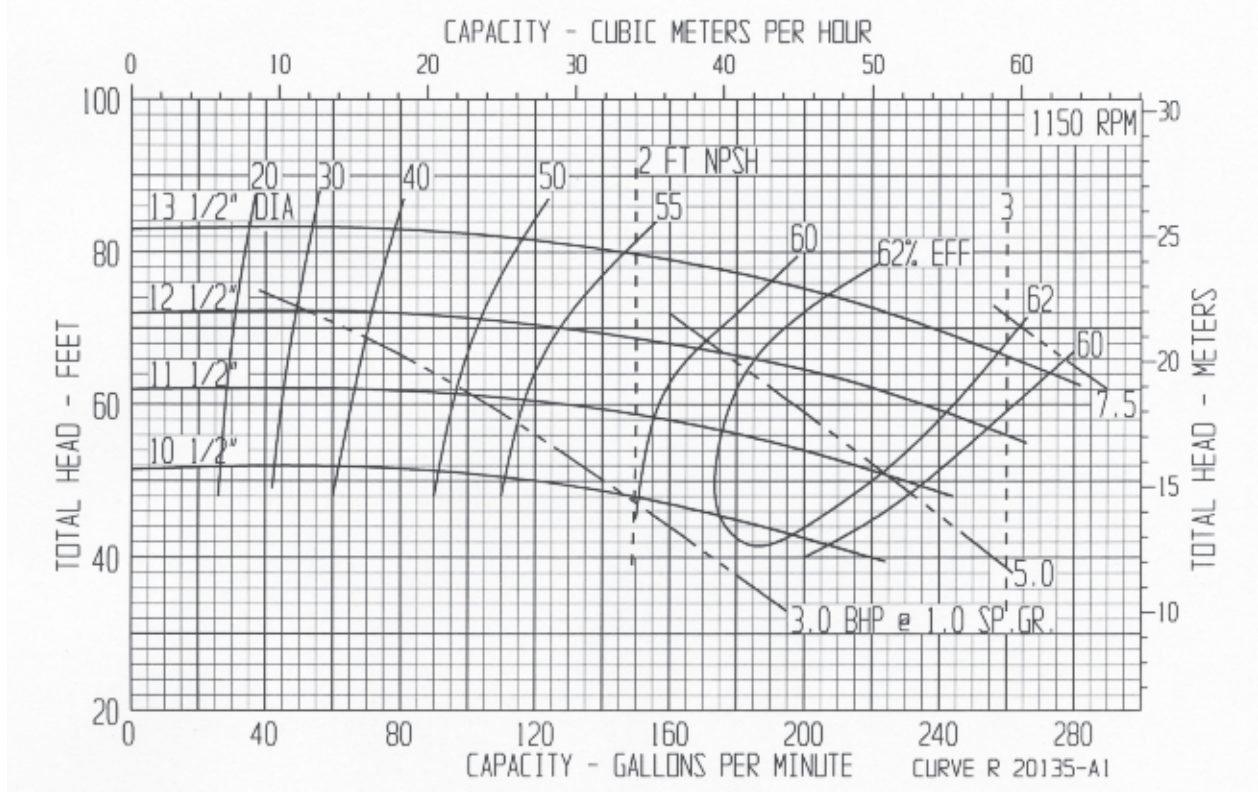
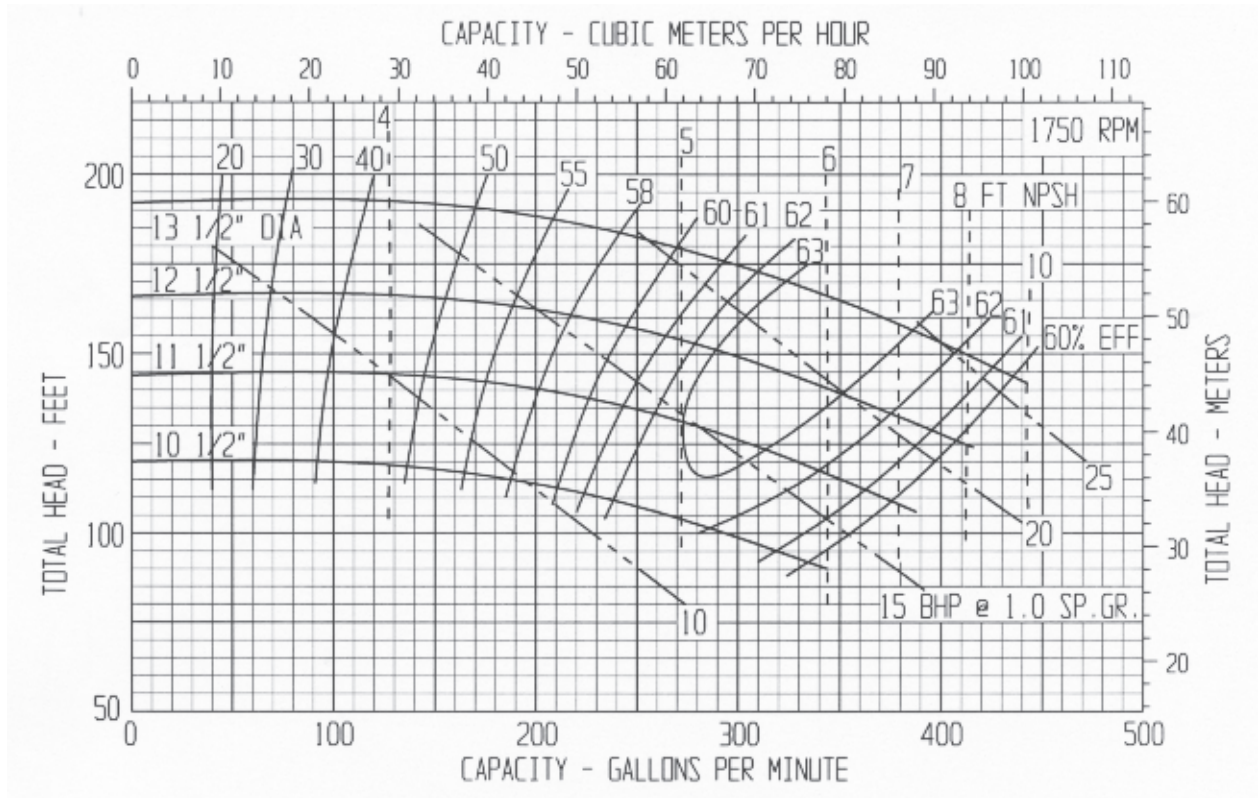

PUMP PERFORMANCE: This curve, based on extensive tests, defines the average performance of this pump for liquids having a viscosity of 70 SSU or less. Actual performance of individual units may differ slightly from the performance indicated on this curve. Pump applications made from the data contained herein are subject to confirmation and acceptance by our Engineering Department at our Indianapolis Office.

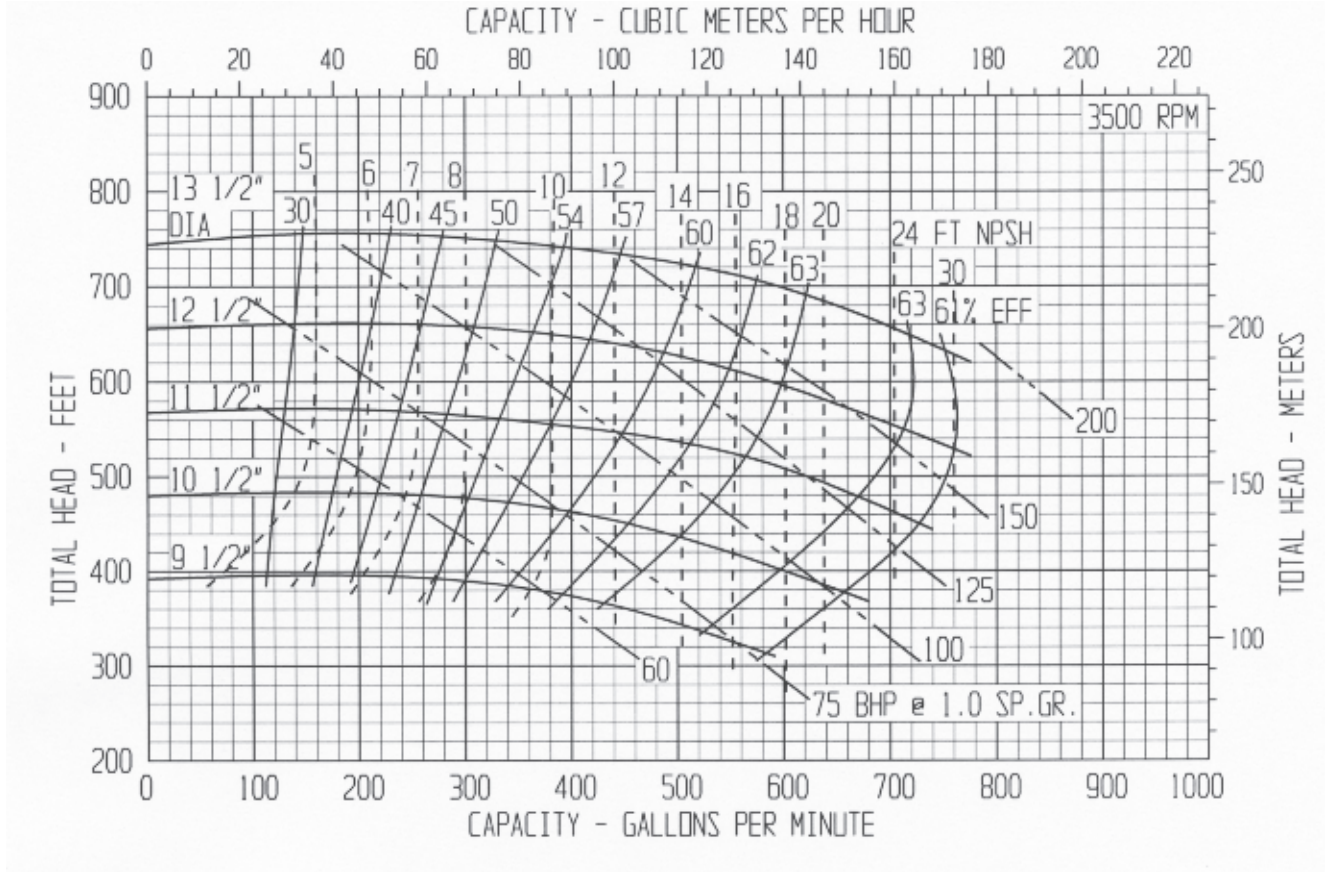

PUMP PERFORMANCE: This curve, based on extensive tests, defines the average performance of this pump for liquids having a viscosity of 70 SSU or less. Actual performance of individual units may differ slightly from the performance indicated on this curve. Pump applications made from the data contained herein are subject to confirmation and acceptance by our Engineering Department at our Indianapolis Office.

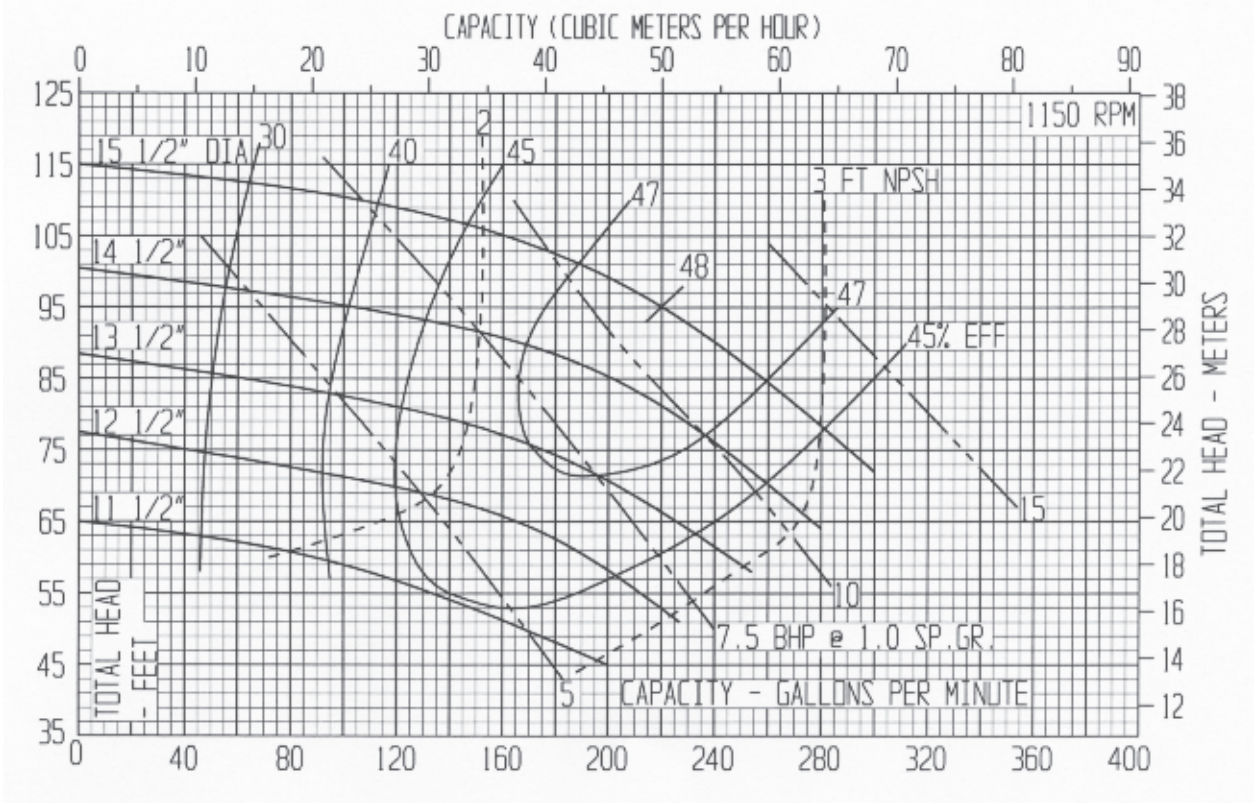
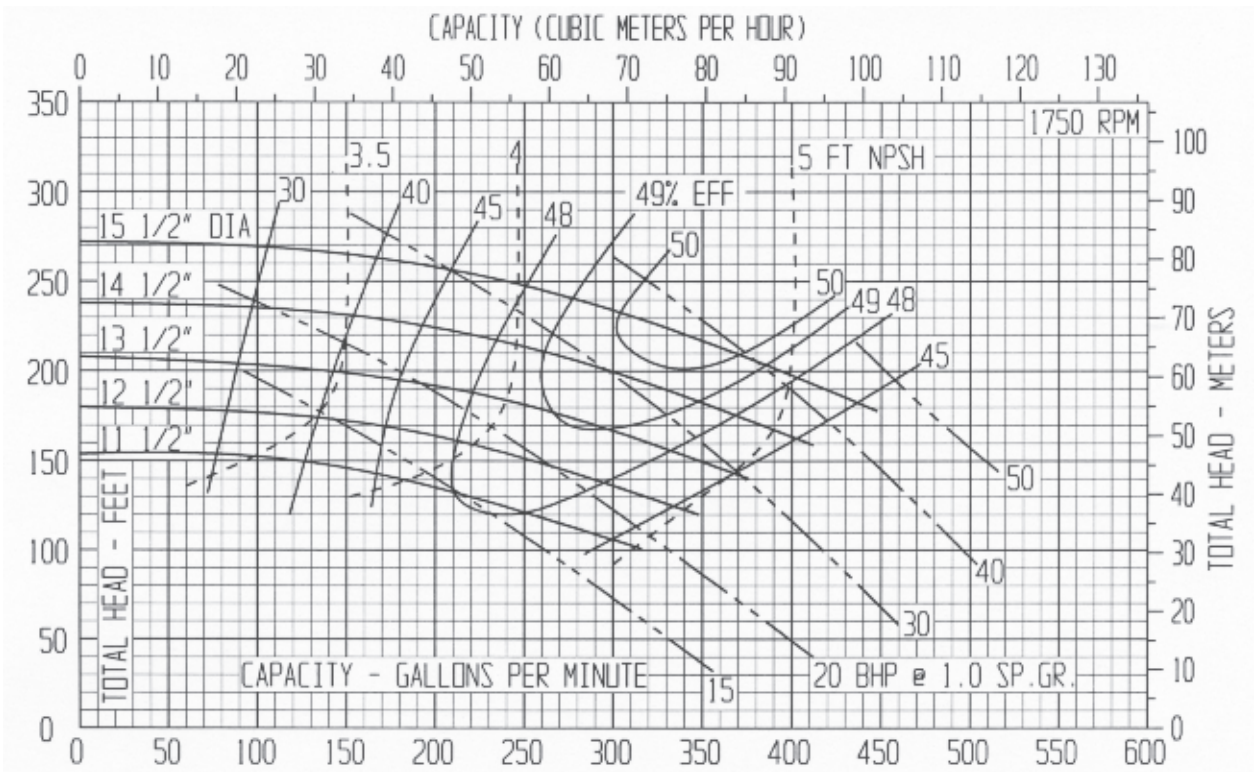

PUMP PERFORMANCE: This curve, based on extensive tests, defines the average performance of this pump for liquids having a viscosity of 70 SSU or less. Actual performance of individual units may differ slightly from the performance indicated on this curve. Pump applications made from the data contained herein are subject to confirmation and acceptance by our Engineering Department at our Indianapolis Office.

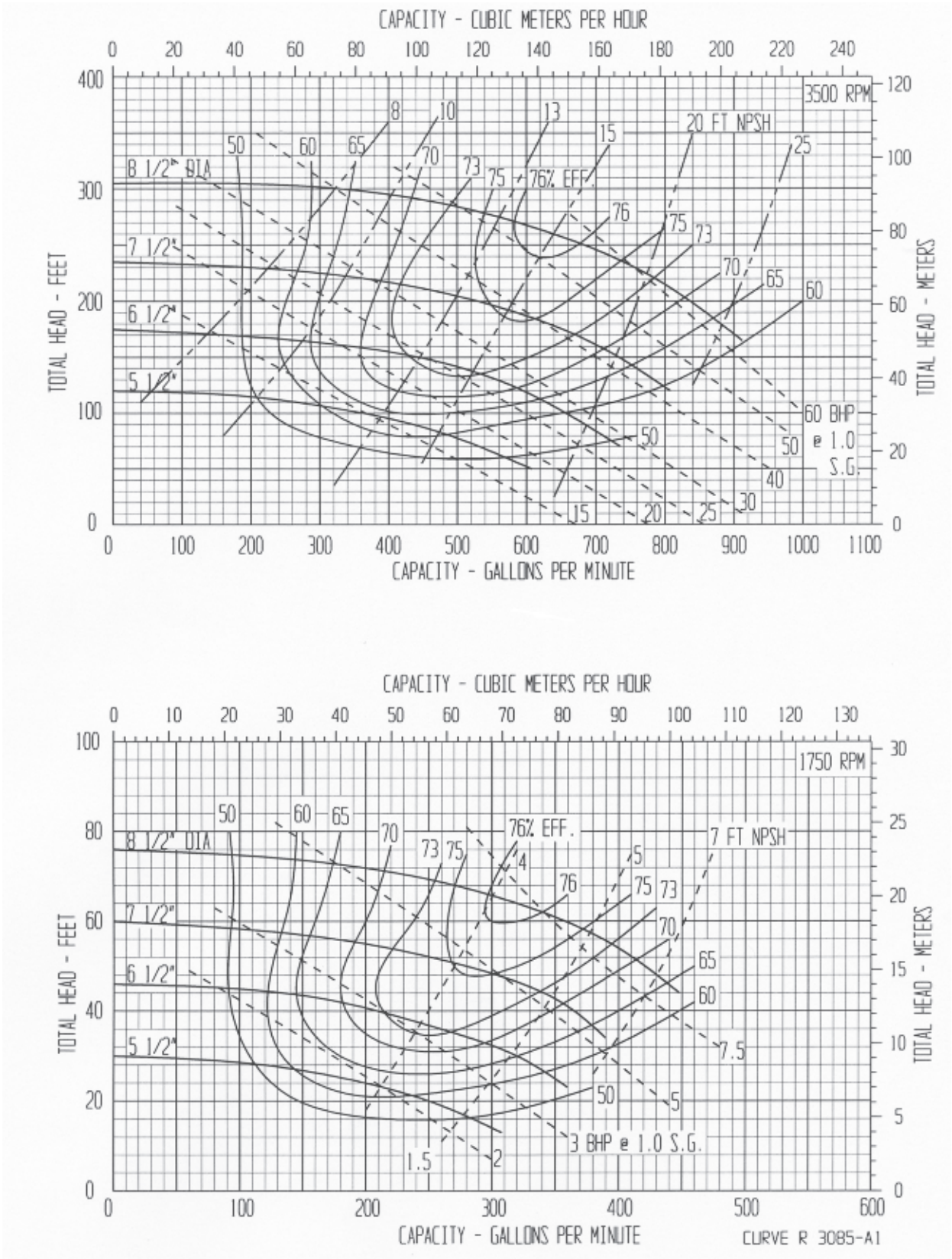

PUMP PERFORMANCE: This curve, based on extensive tests, defines the average performance of this pump for liquids having a viscosity of 70 SSU or less. Actual performance of individual units may differ slightly from the performance indicated on this curve. Pump applications made from the data contained herein are subject to confirmation and acceptance by our Engineering Department at our Indianapolis Office.

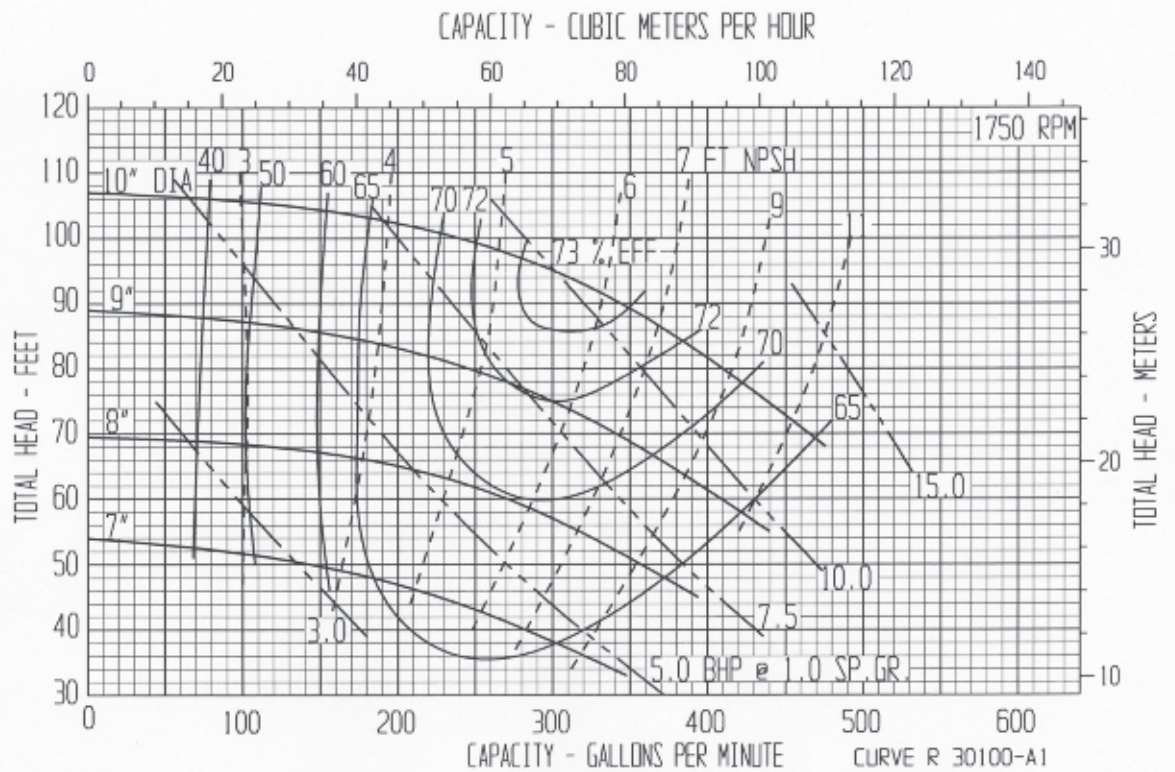
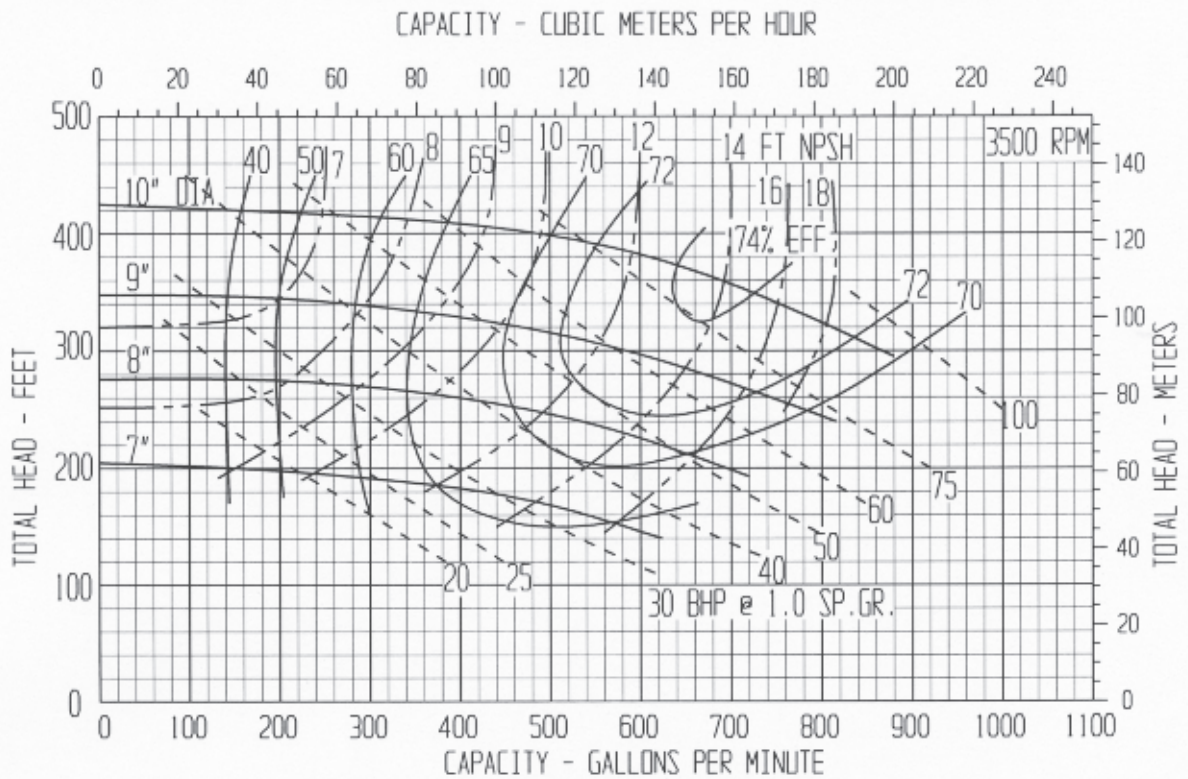

PUMP PERFORMANCE: This curve, based on extensive tests, defines the average performance of this pump for liquids having a viscosity of 70 SSU or less. Actual performance of individual units may differ slightly from the performance indicated on this curve. Pump applications made from the data contained herein are subject to confirmation and acceptance by our Engineering Department at our Indianapolis Office.

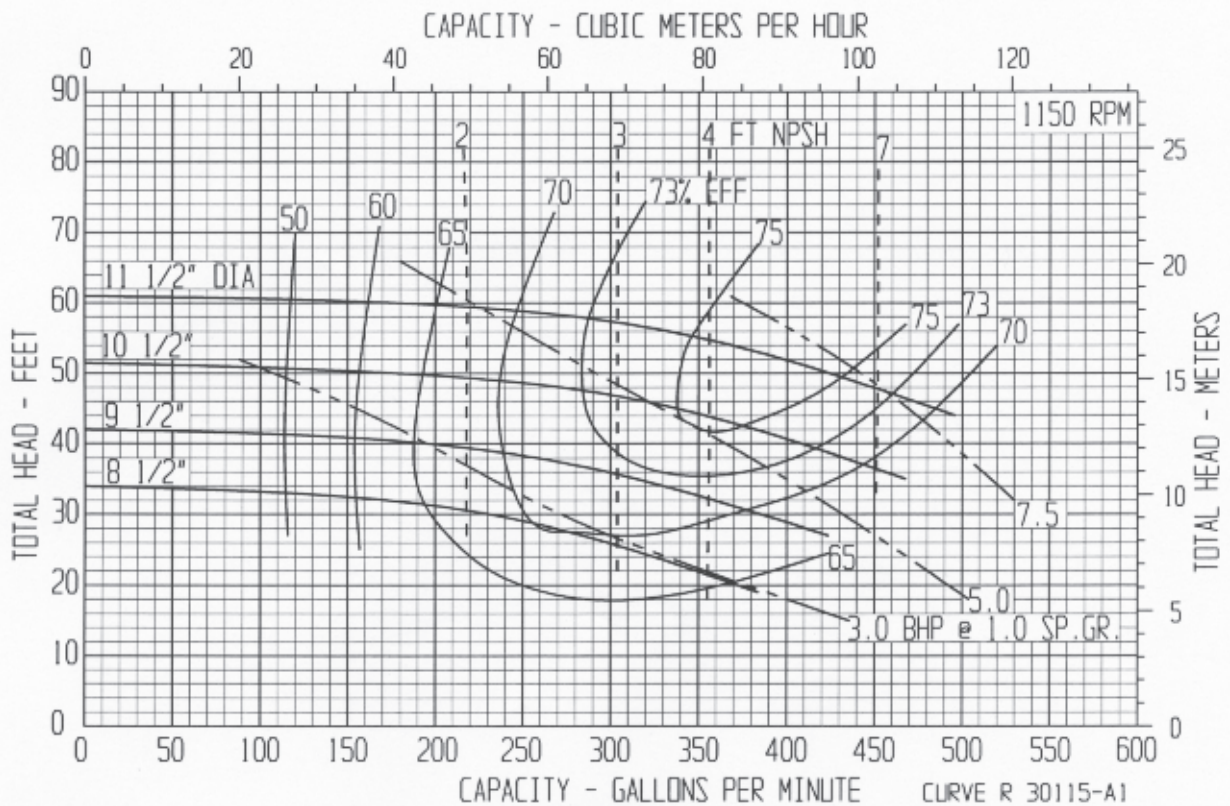
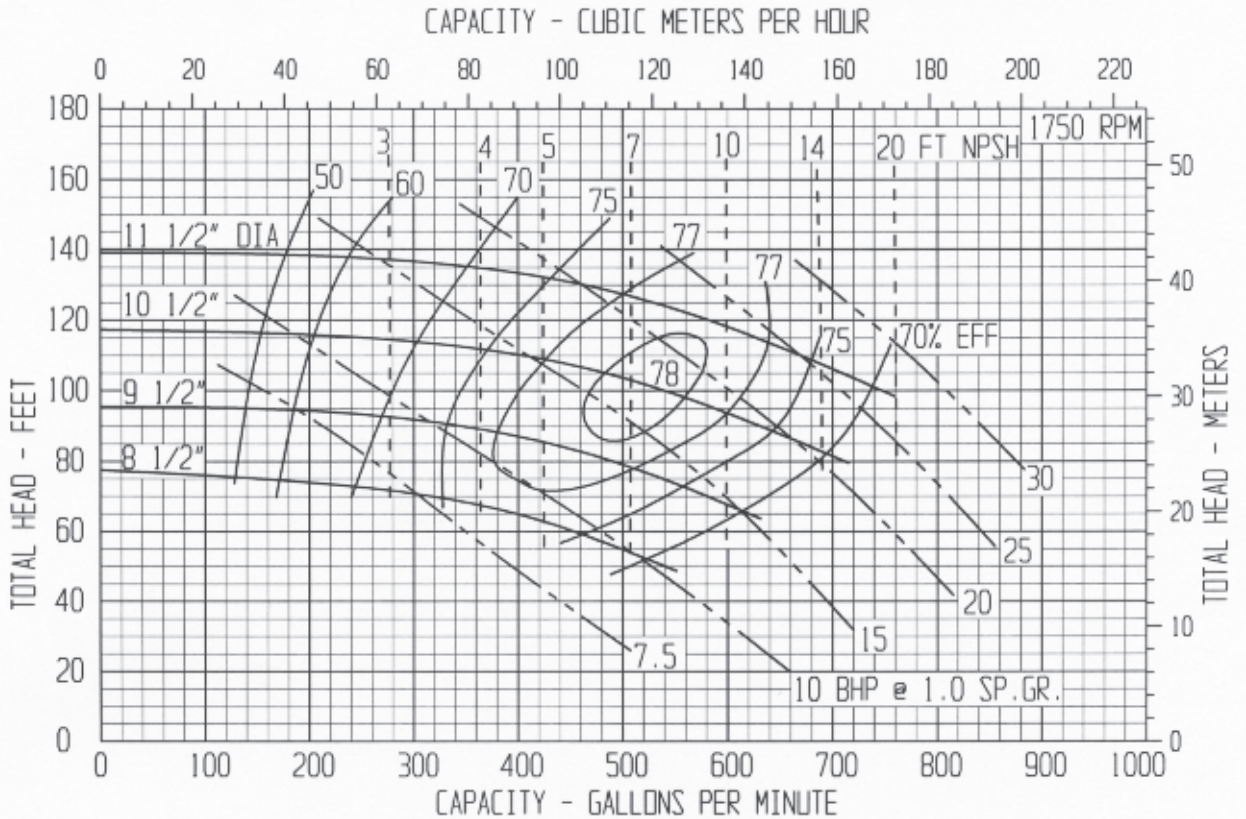

PUMP PERFORMANCE: This curve, based on extensive tests, defines the average performance of this pump for liquids having a viscosity of 70 SSU or less. Actual performance of individual units may differ slightly from the performance indicated on this curve. Pump applications made from the data contained herein are subject to confirmation and acceptance by our Engineering Department at our Indianapolis Office.

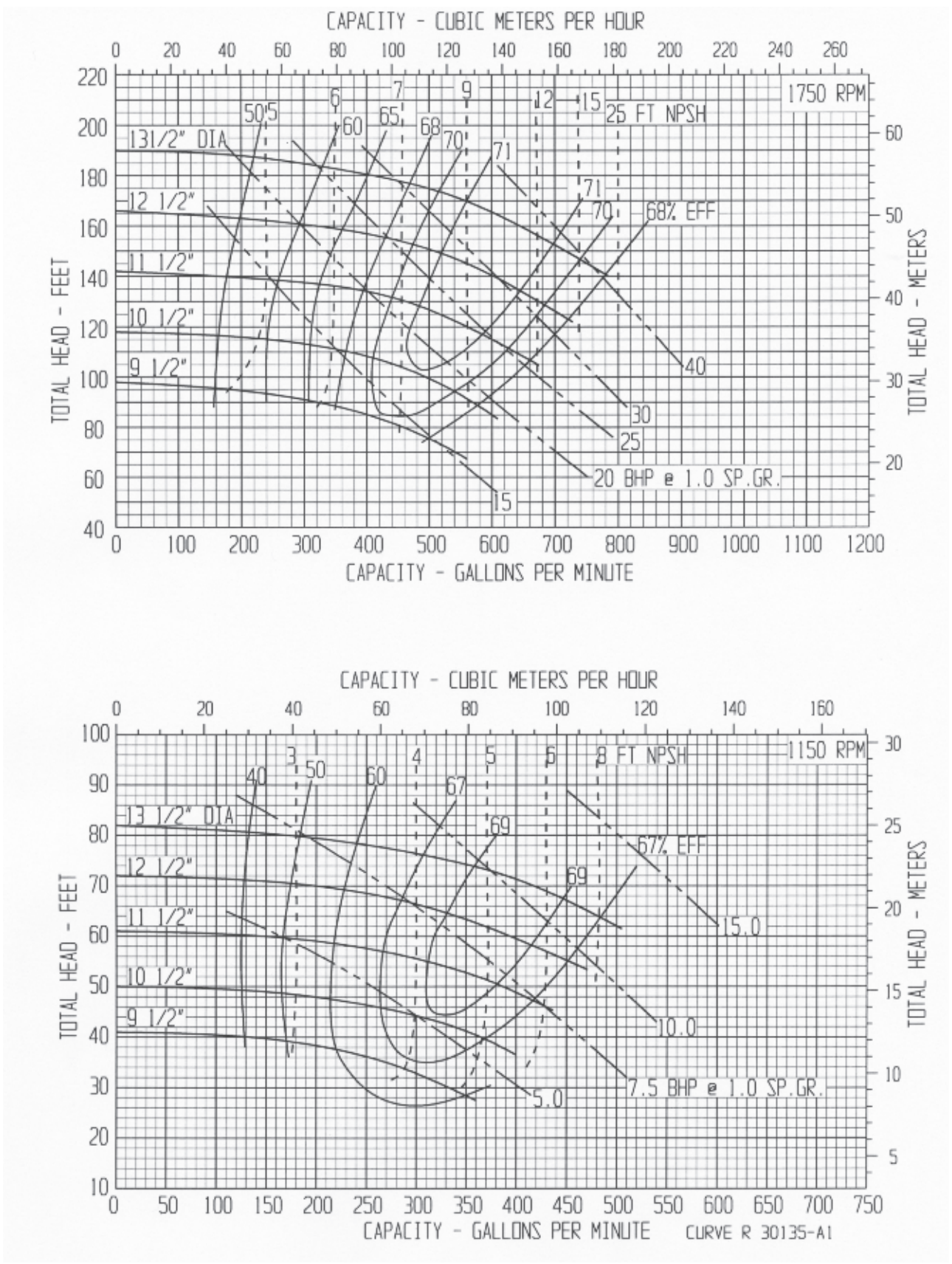

PUMP PERFORMANCE: This curve, based on extensive tests, defines the average performance of this pump for liquids having a viscosity of 70 SSU or less. Actual performance of individual units may differ slightly from the performance indicated on this curve. Pump applications made from the data contained herein are subject to confirmation and acceptance by our Engineering Department at our Indianapolis Office.

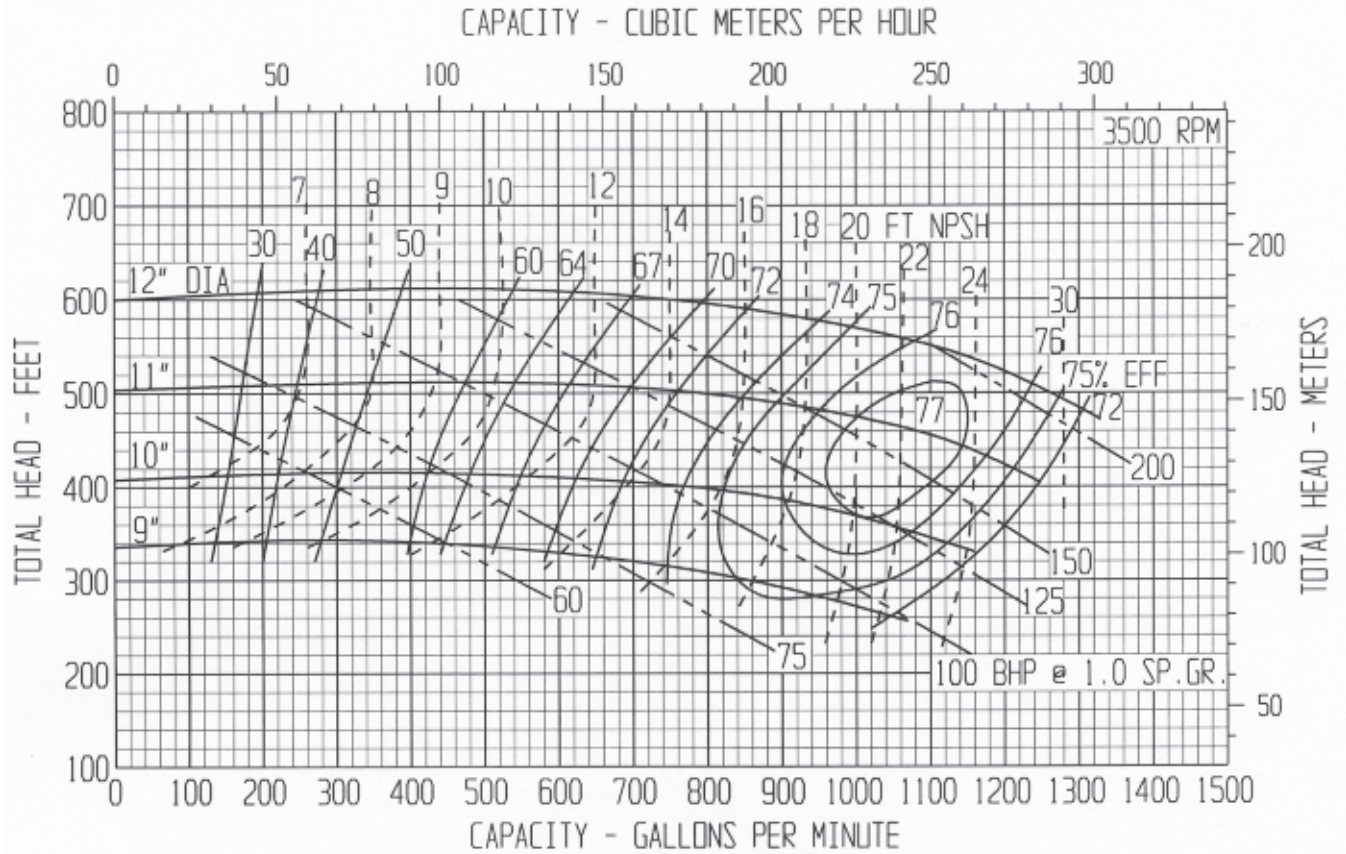

PUMP PERFORMANCE: This curve, based on extensive tests, defines the average performance of this pump for liquids having a viscosity of 70 SSU or less. Actual performance of individual units may differ slightly from the performance indicated on this curve. Pump applications made from the data contained herein are subject to confirmation and acceptance by our Engineering Department at our Indianapolis Office.

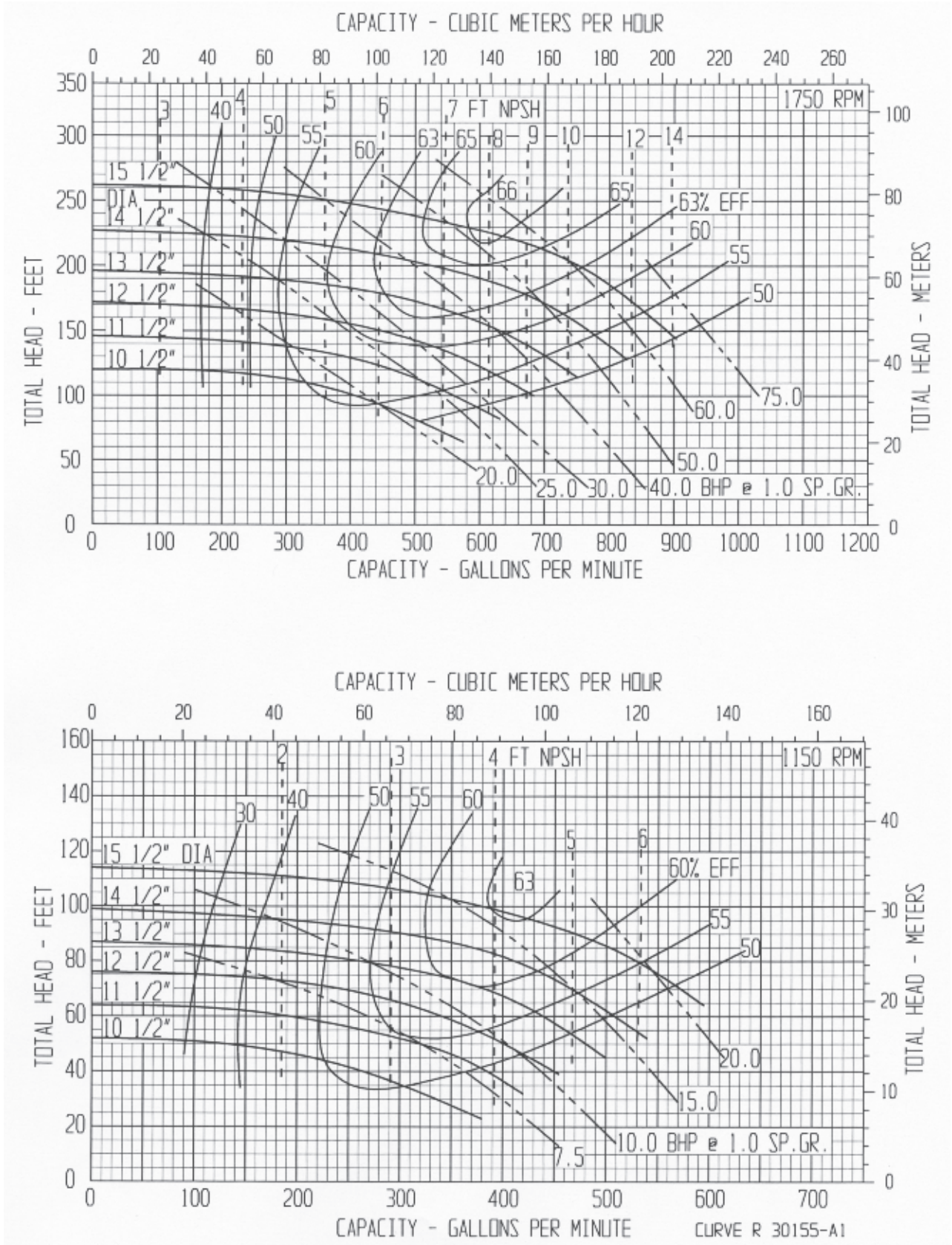

PUMP PERFORMANCE: This curve, based on extensive tests, defines the average performance of this pump for liquids having a viscosity of 70 SSU or less. Actual performance of individual units may differ slightly from the performance indicated on this curve. Pump applications made from the data contained herein are subject to confirmation and acceptance by our Engineering Department at our Indianapolis Office.

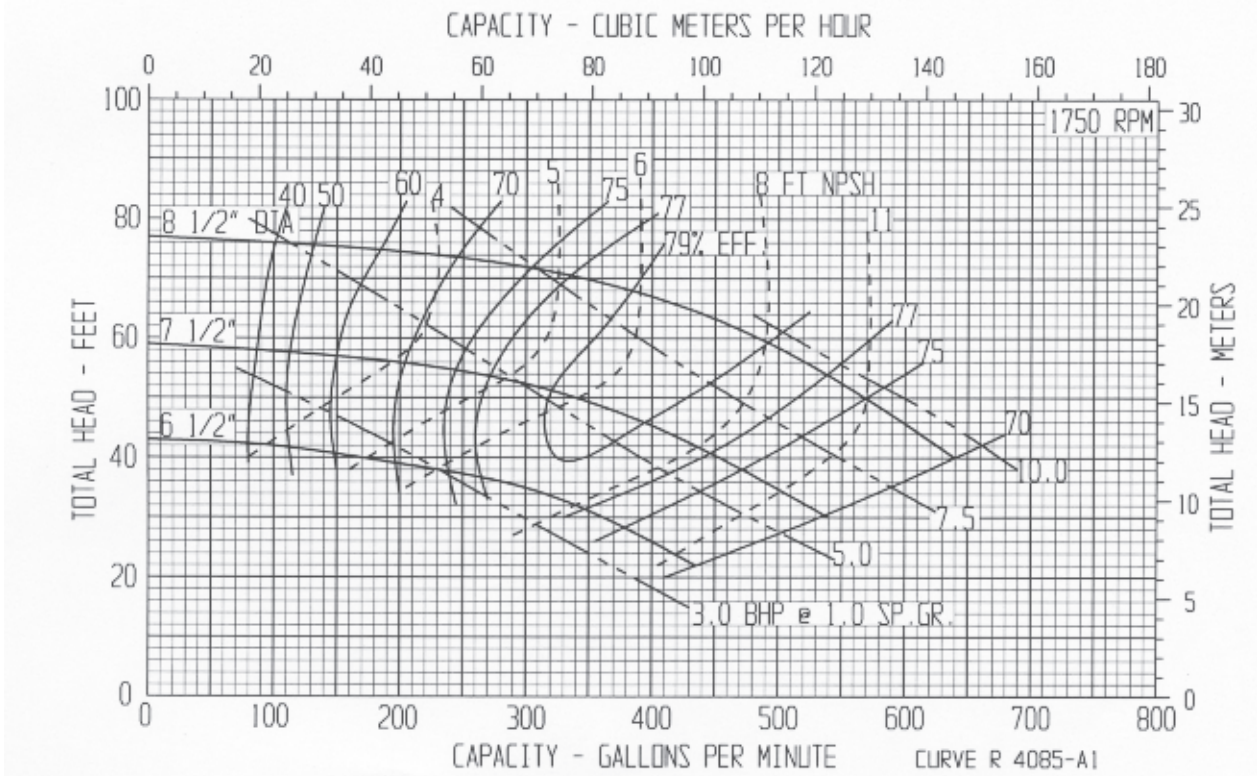
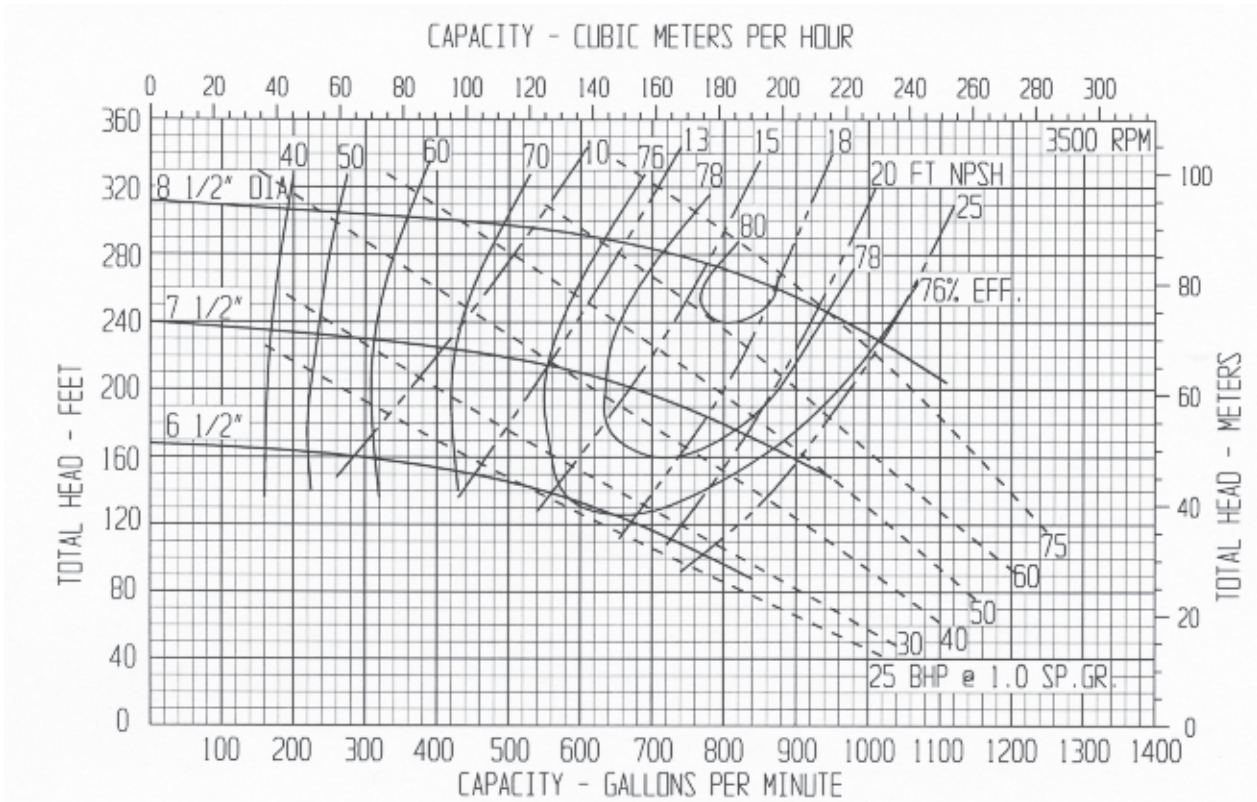

CURVE R 4085-A1

PUMP PERFORMANCE: This curve, based on extensive tests, defines the average performance of this pump for liquids having a viscosity of 70 SSU or less. Actual performance of individual units may differ slightly from the performance indicated on this curve. Pump applications made from the data contained herein are subject to confirmation and acceptance by our Engineering Department at our Indianapolis Office.

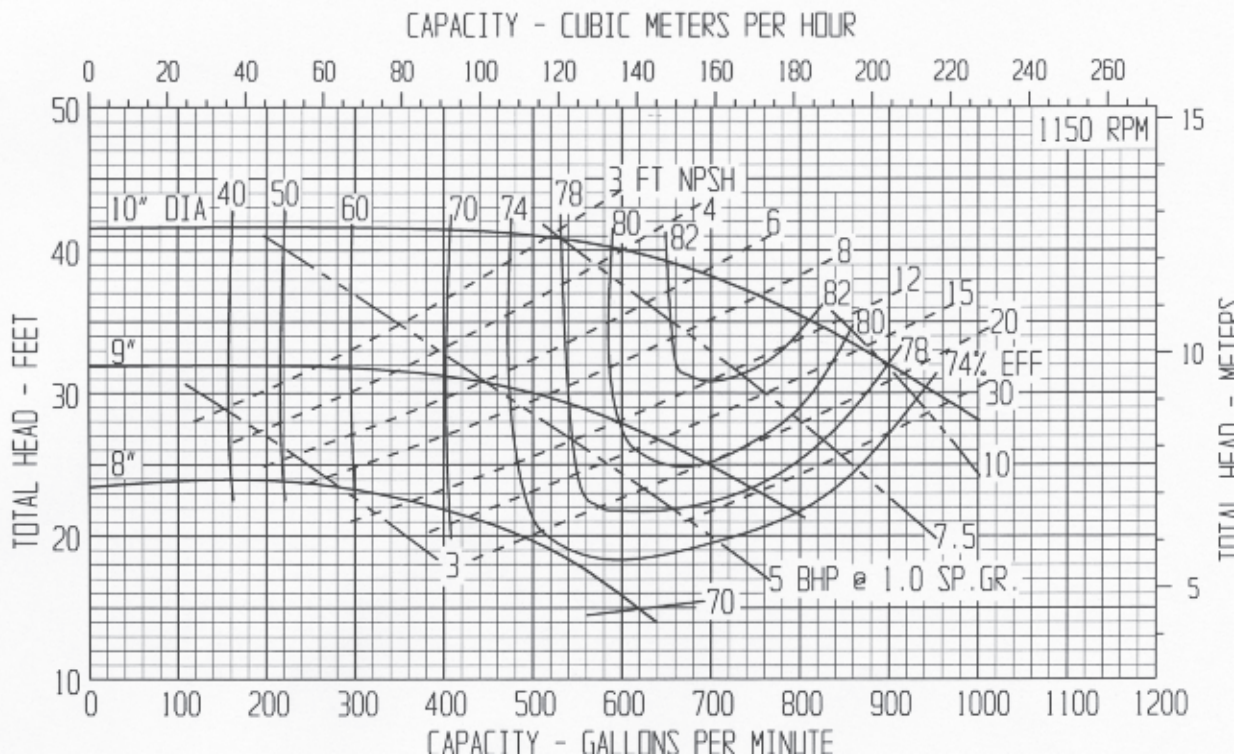
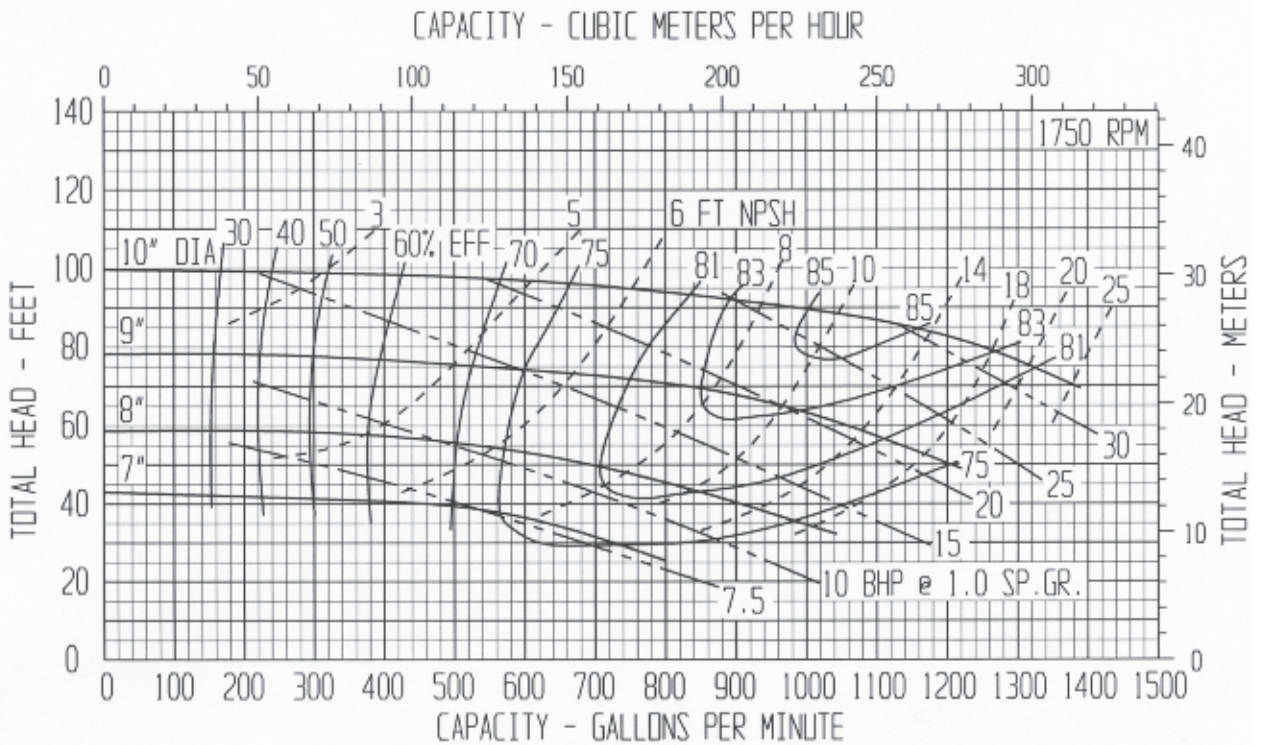

PUMP PERFORMANCE: This curve, based on extensive tests, defines the average performance of this pump for liquids having a viscosity of 70 SSU or less. Actual performance of individual units may differ slightly from the performance indicated on this curve. Pump applications made from the data contained herein are subject to confirmation and acceptance by our Engineering Department at our Indianapolis Office.

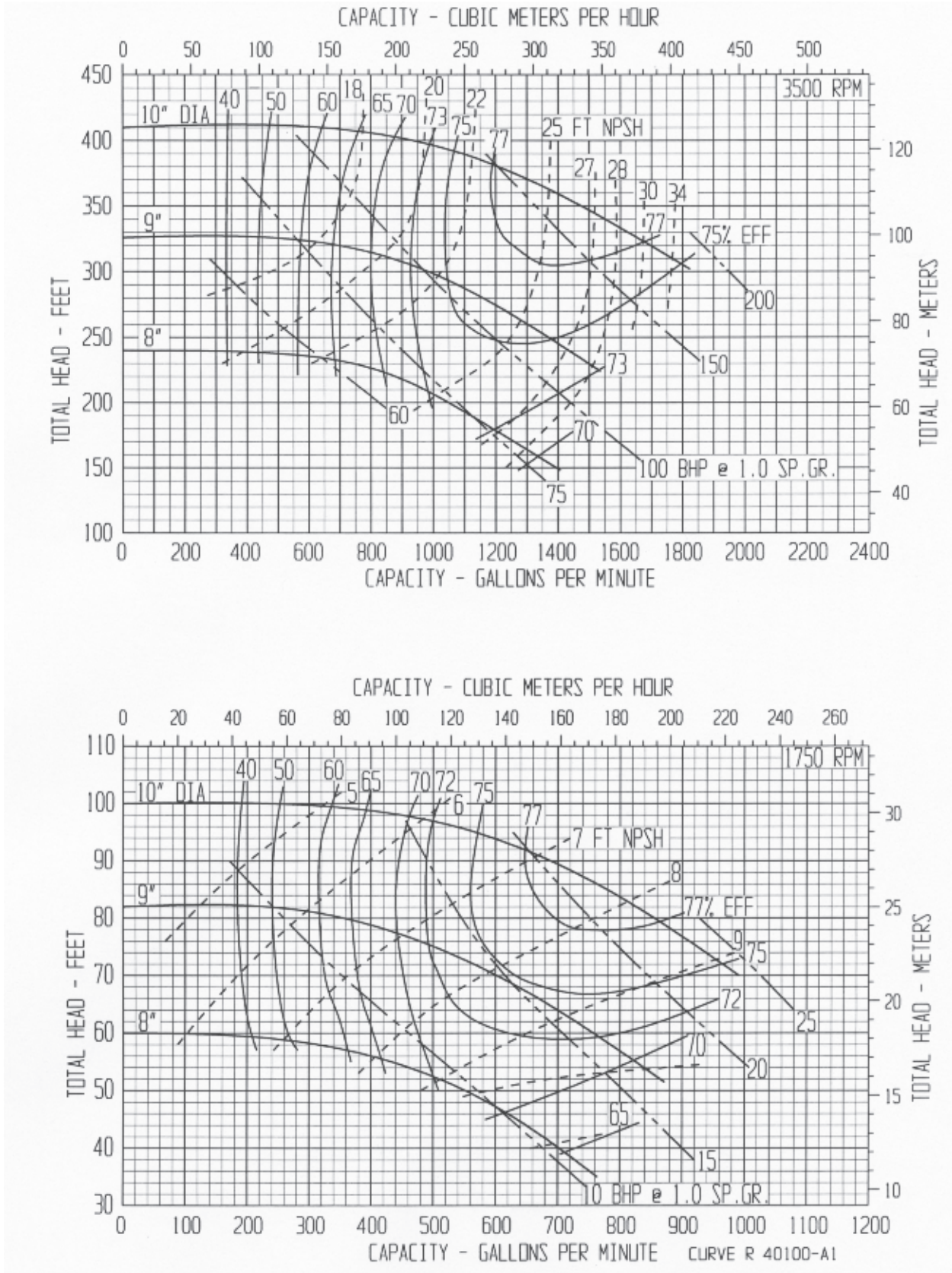

PUMP PERFORMANCE: This curve, based on extensive tests, defines the average performance of this pump for liquids having a viscosity of 70 SSU or less. Actual performance of individual units may differ slightly from the performance indicated on this curve. Pump applications made from the data contained herein are subject to confirmation and acceptance by our Engineering Department at our Indianapolis Office.

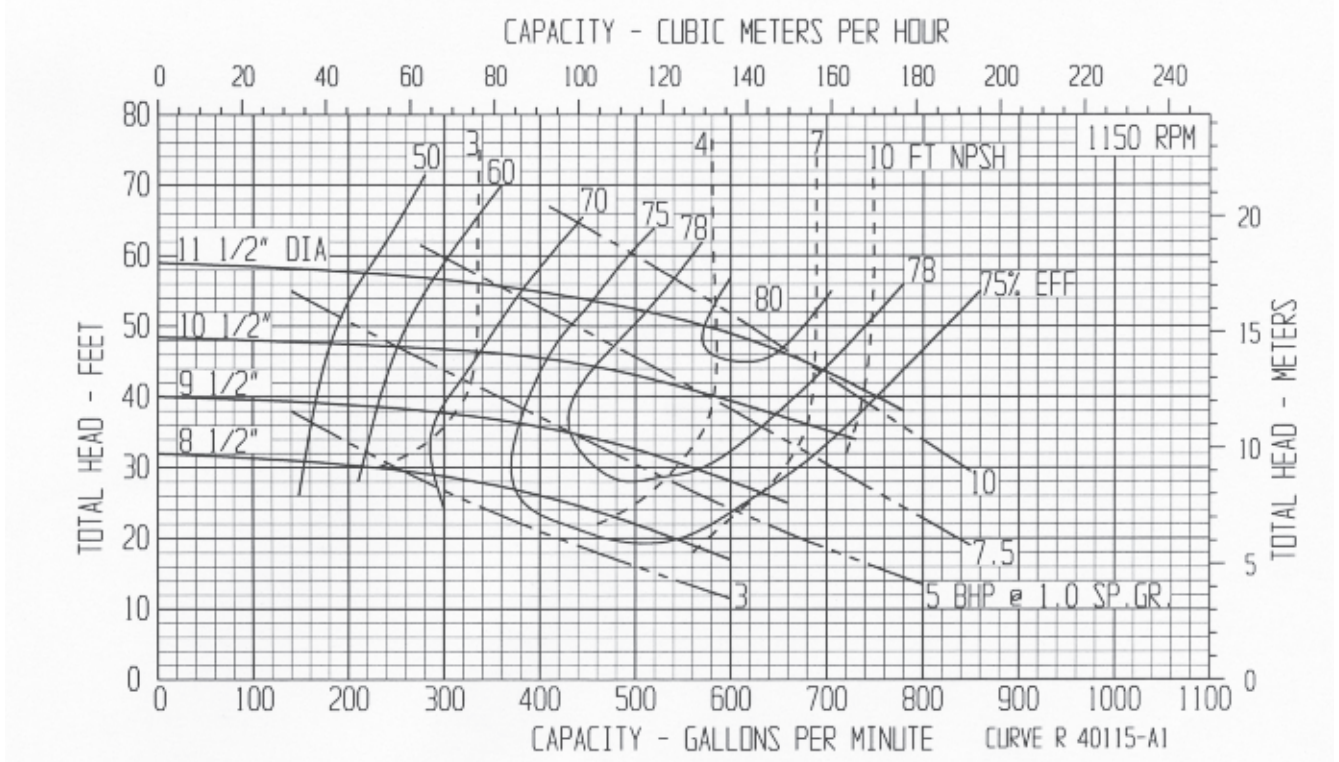
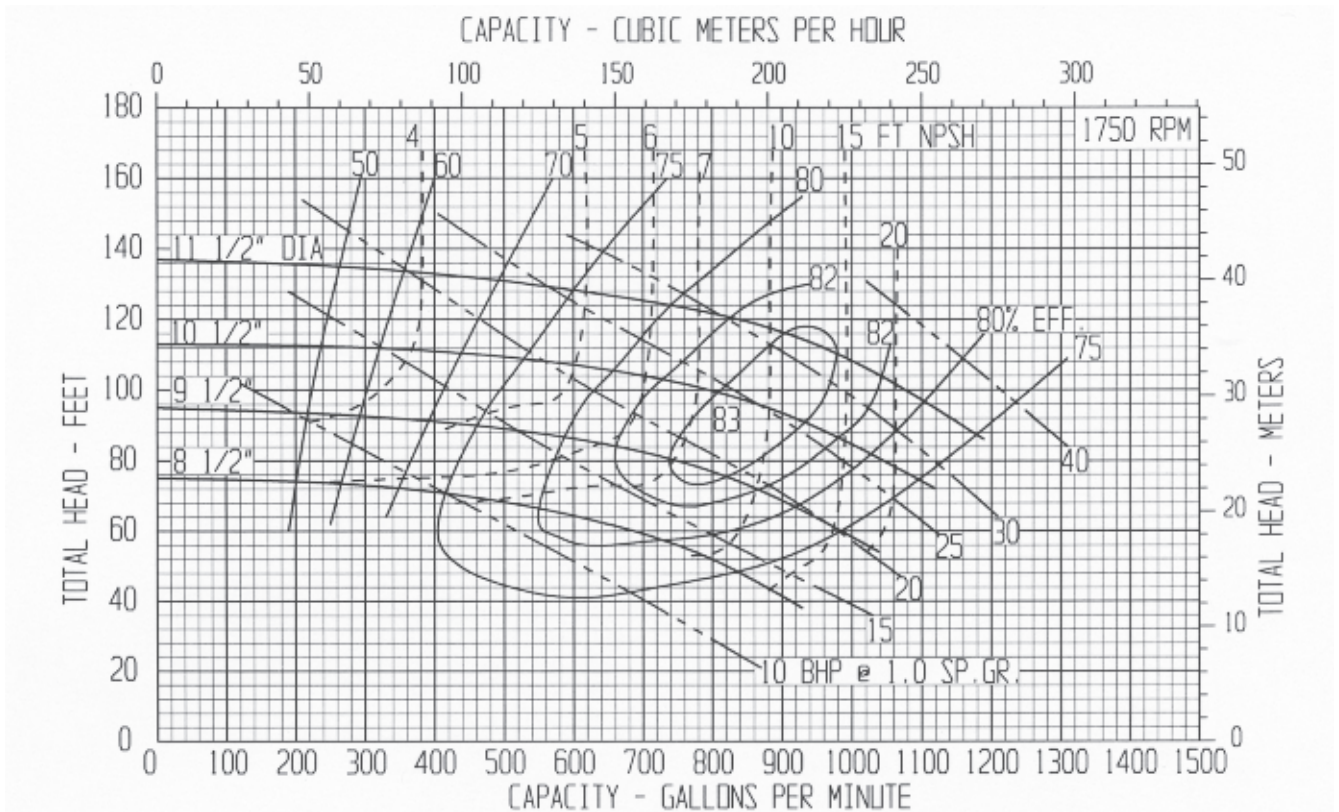

PUMP PERFORMANCE: This curve, based on extensive tests, defines the average performance of this pump for liquids having a viscosity of 70 SSU or less. Actual performance of individual units may differ slightly from the performance indicated on this curve. Pump applications made from the data contained herein are subject to confirmation and acceptance by our Engineering Department at our Indianapolis Office.

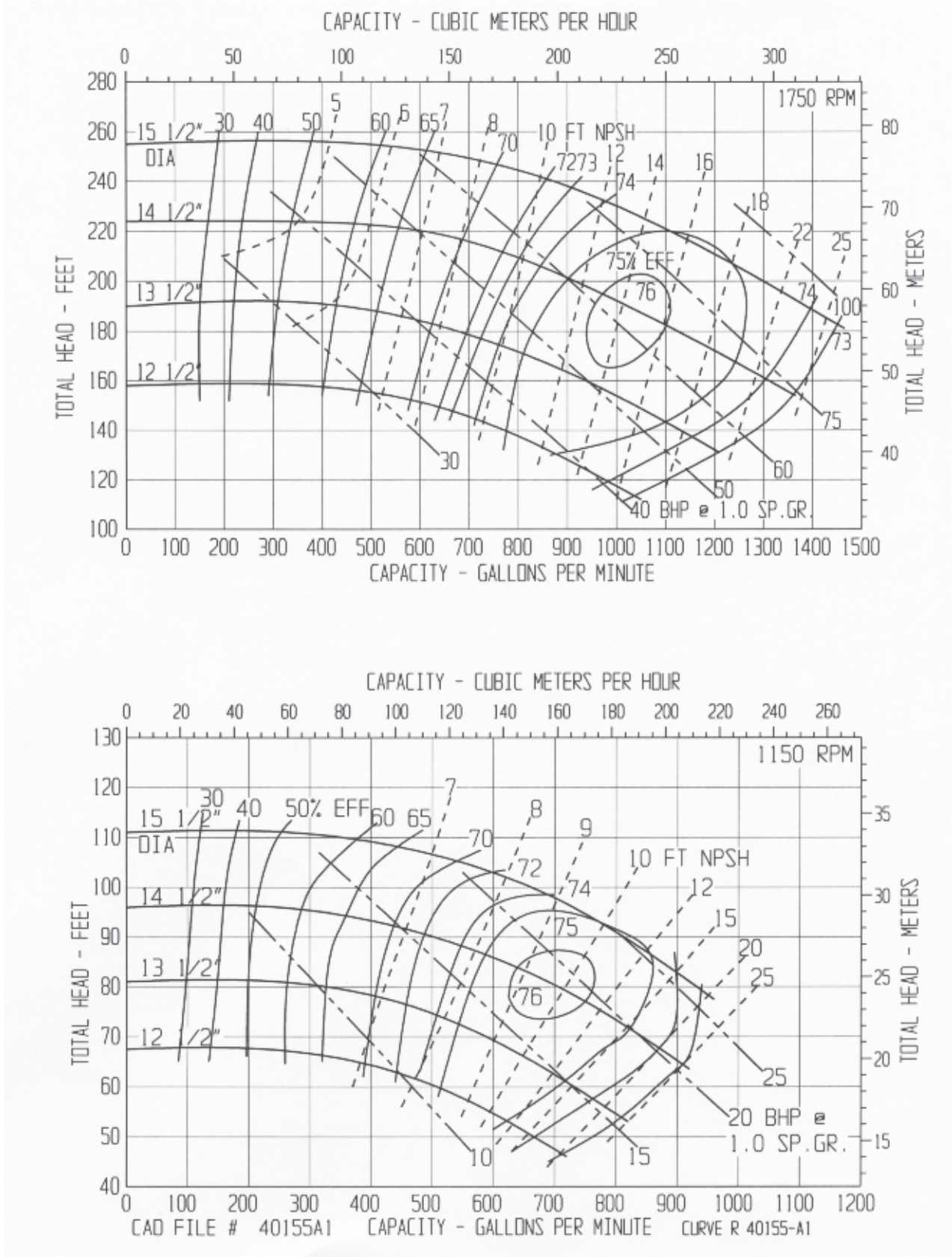

PUMP PERFORMANCE: This curve, based on extensive tests, defines the average performance of this pump for liquids having a viscosity of 70 SSU or less. Actual performance of individual units may differ slightly from the performance indicated on this curve. Pump applications made from the data contained herein are subject to confirmation and acceptance by our Engineering Department at our Indianapolis Office.

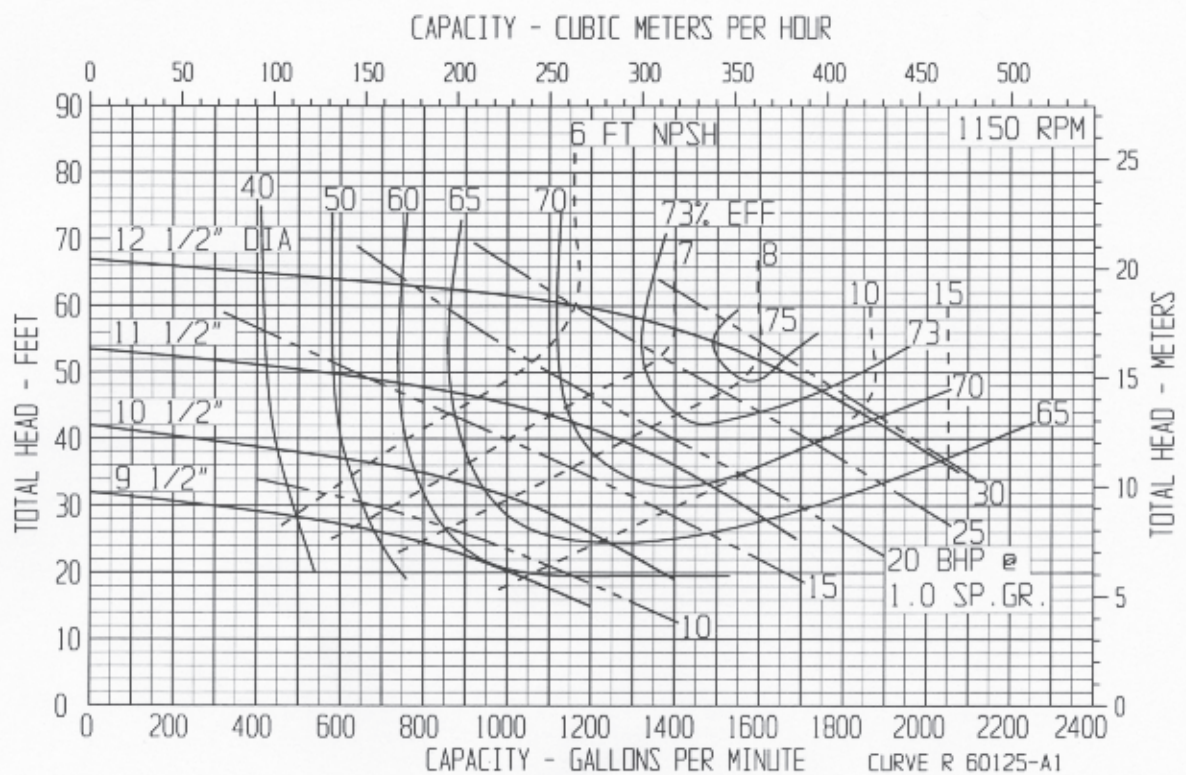
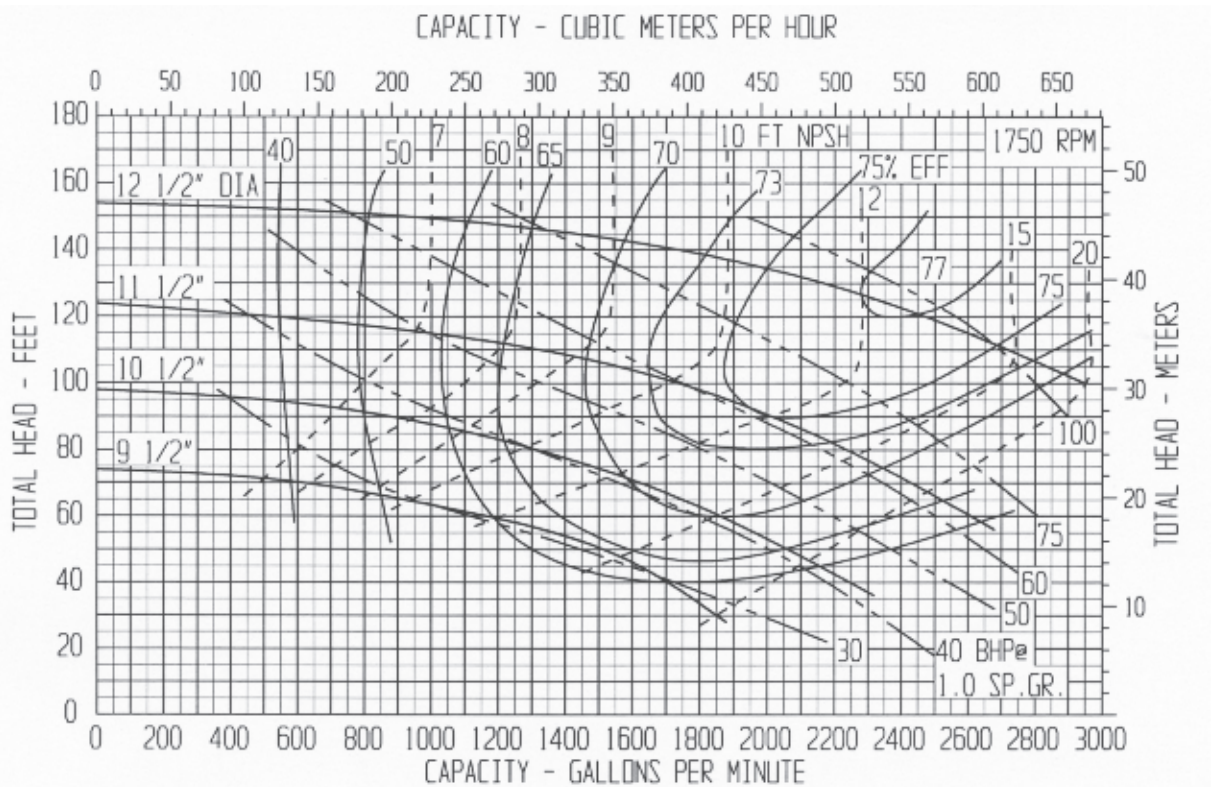

PUMP PERFORMANCE: This curve, based on extensive tests, defines the average performance of this pump for liquids having a viscosity of 70 SSU or less. Actual performance of individual units may differ slightly from the performance indicated on this curve. Pump applications made from the data contained herein are subject to confirmation and acceptance by our Engineering Department at our Indianapolis Office.

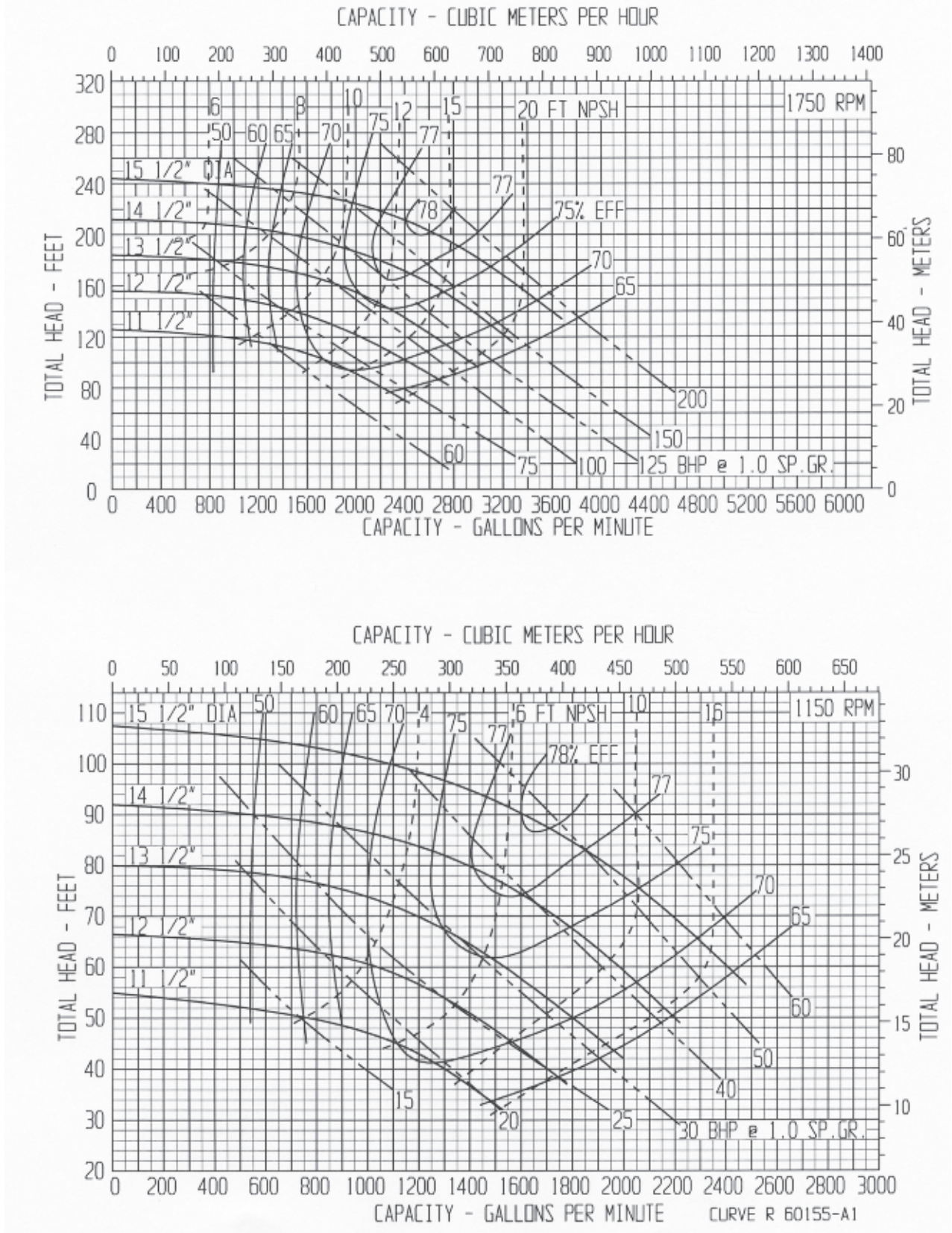

PUMP PERFORMANCE: This curve, based on extensive tests, defines the average performance of this pump for liquids having a viscosity of 70 SSU or less. Actual performance of individual units may differ slightly from the performance indicated on this curve. Pump applications made from the data contained herein are subject to confirmation and acceptance by our Engineering Department at our Indianapolis Office.

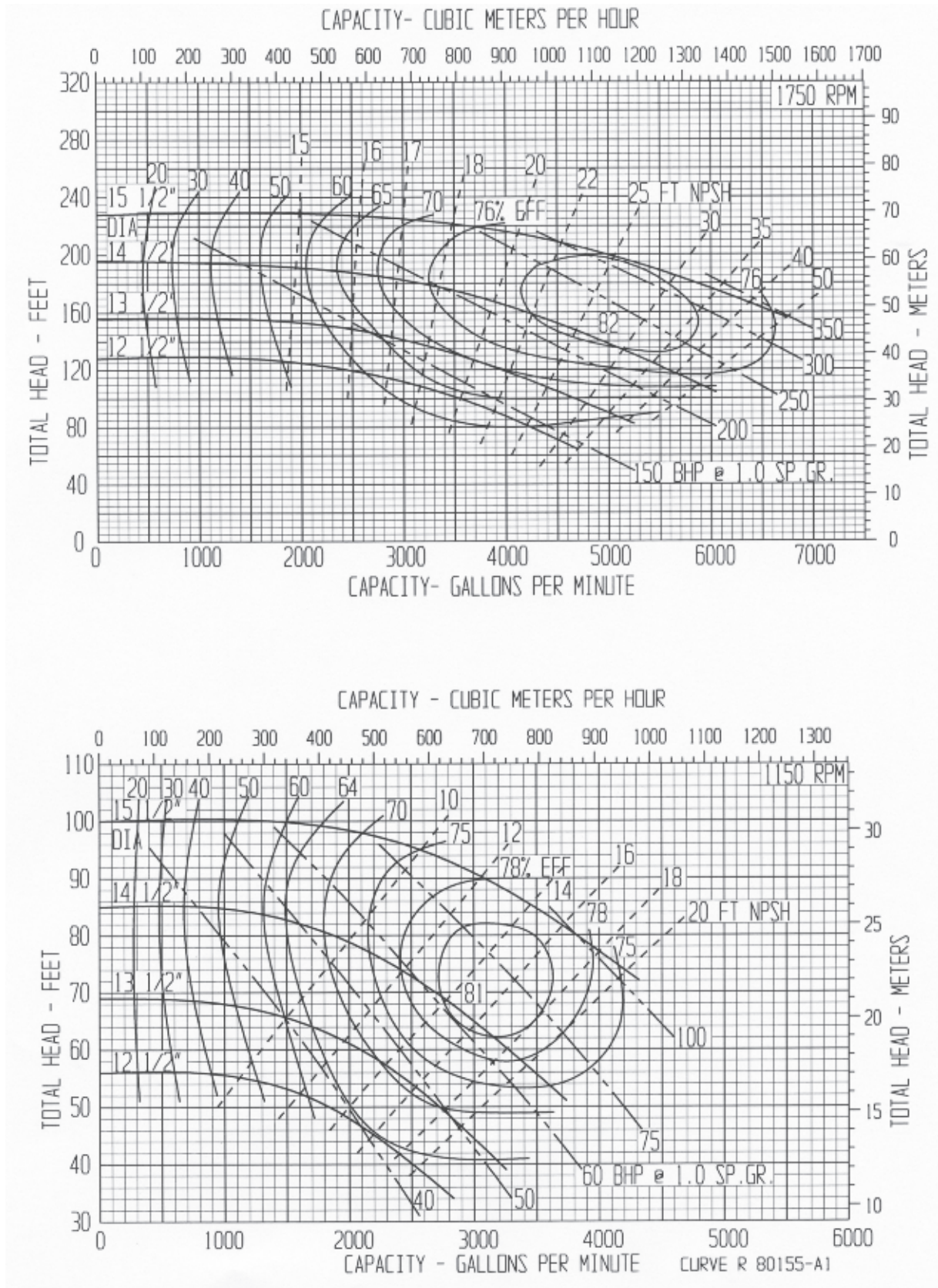



A Met-Pro Fluid Handling Technologies Business
Combining the Resources of **Dean Pump, Fybroc & Sethco**
6040 Guion Road • Indianapolis, IN 46254
(317) 293-2930 • FAX: (317) 297-7028
E-mail: info@deanpump.com • Web Site: www.deanpump.com

