

DEAN PUMP® SERIES R5000

Refinery Type Horizontal Process Pumps

DATA PAK

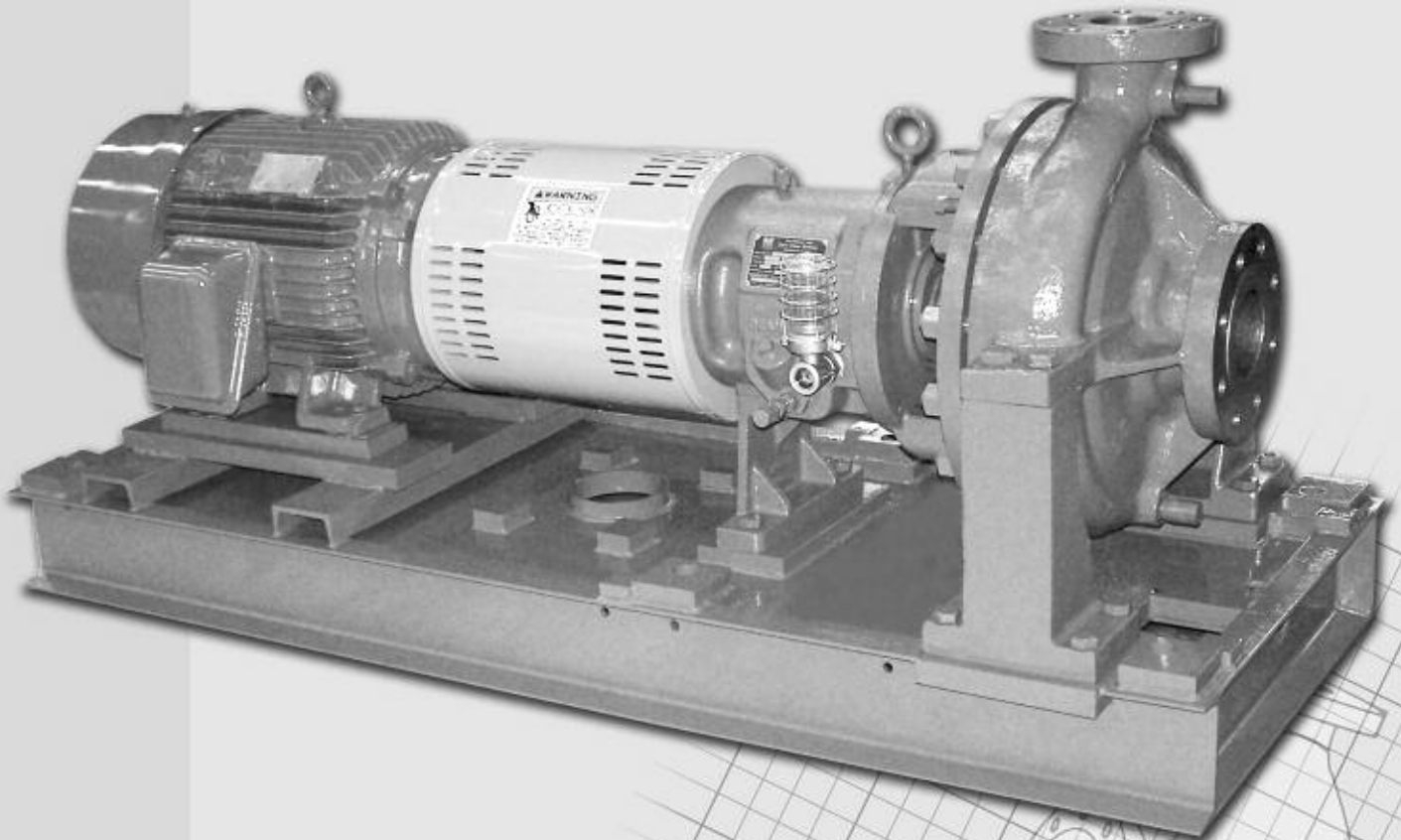

TWO POLE MOTOR

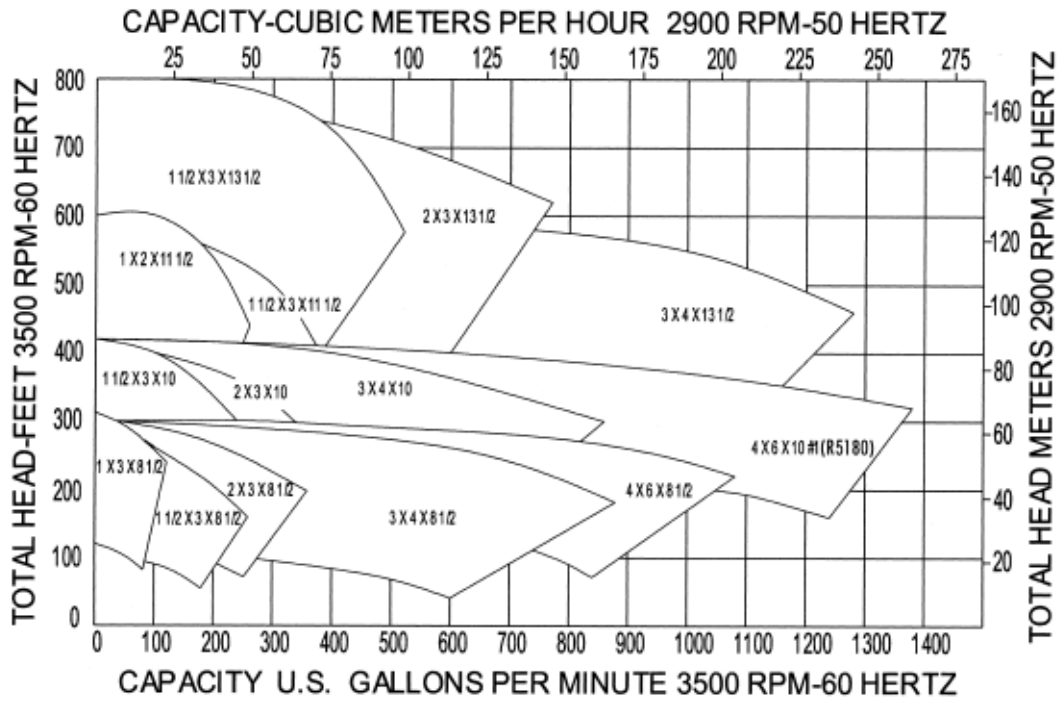

FOUR POLE MOTOR

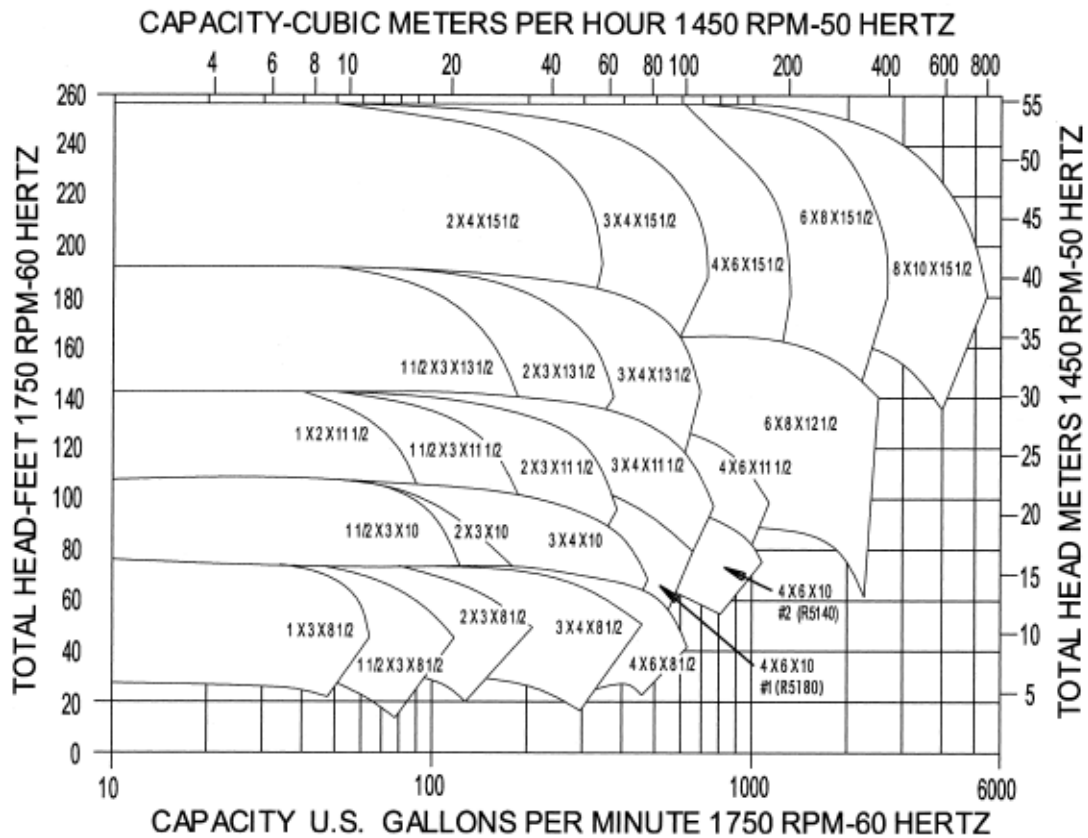

**STANDARD, HORIZONTAL, SINGLE STAGE, END SUCTION, ENCLOSED IMPELLER, CENTRIFUGAL PROCESS PUMPS
TYPES R5140, R5170, R5180 AND R5240**

MECHANICAL DESIGN SPECIFICATIONS

Direction of Rotation (Viewed from Coupling End)CCW
 Casing Thickness, Minimum5/16"
 Corrosion Allowance1/8"
 Impeller — StandardDynamically Balanced
 Flanges — ANSI RatingClass 300
 FacingStandard Raised Face
 Optional ExtraRing Type Joint
 Finish125 Ra
 Stuffing Box Jacket & Oil Cooler Pressure, Maximum125 psig
 Suction Pressure, MaximumMax. Working Pressure Less Pump Developed Head

	R5140	R5170	R5180	R5240
Horsepower Rating — Maximum @ 3500 rpm @ 1750 rpm @ 1160 rpm	100 40 25	200 100 —	250 125 75	— 300 200
Bearings, Type Ball Bearings, Oil Lubricated Thrust Bearing (Angular Contact Pair) Radial Bearing	7309BG 6309	7311BG 6311	7312BG 6312	7317BG 6316
Approximate Oil Capacity of Bearing Housing	41 oz	36 oz	64 oz	120 oz
Seal Chamber Dimensions (Large Taper Bore)				
Length (Depth)	3"	3"	4 1/2"	4 7/8"
Inside Diameter (Bore Diameter)	3 1/2"	3 7/8"	4 1/4"	5"
Shaft Sleeve Diameter	1 3/4"	2 1/8"	2 1/4"	3"
Standard Bore (Stuffing Box) Dimensions				
Length (Depth)	3"	3"	3 7/8"	4 1/8"
Inside Diameter (Bore Diameter)	2 1/2"	2 7/8"	3 1/4"	4"
Shaft Sleeve Diameter	1 3/4"	2 1/8"	2 1/4"	3"
Lantern Gland Width	5/8"	5/8"	3/4"	1"
Lantern Gland to Open End of Stuffing Box	1 1/2"	1 1/2"	1 1/2"	2 3/8"
Packing Size, Square	3/8"	3/8"	1/2"	1/2"
Number of Rings with Lantern Ring	6	6	6	6
Spacing	3G3	3G3	3G3	3G3
Number of Rings Lantern Omitted	7	8	7	8
Pump Shaft Dimensions				
Span Between Bearings ϕ to ϕ	6"	5 15/16"	8 1/4"	10 3/16"
Span Between Radial Bearing ϕ and Impeller ϕ	8"	8 3/16"	10 3/4"	12 5/16"
Diameter at Coupling	1 1/8"	1 5/8"	1 5/8"	2 3/8"
Diameter Between Bearings	2 1/8"	2 5/8"	2 3/4"	4"
Diameter at Impeller	1 1/8"	1 1/4"	1 1/2"	2 1/4"
L ³ /D ⁴				
Sleeved	101	44	78	36
Solid	55	27	26	23

MATERIAL CLASS	MAXIMUM WORKING PRESSURE	PUMPING TEMPERATURE		HYDROSTATIC TEST PRESSURE	
		MINIMUM	MAXIMUM	R5140/R5170	R5180/R5240
40† 41	500 psig @ 650°F	-20°F	800°F @ 350 psig	850 psig	750 psig
50	500 psig @ 100°F	-20°F	850°F @ 305 psig		

† Carbon Steel with Cast Iron trim. Also available with 316SS trim.

WARNING: Use the "Allowable Working Pressure VS. Pumping Temperature" chart (below, right) to determine the allowable working pressure at any allowable pumpage temperature for the material of construction selected.

Seal Chamber Temperature VS. Pumping Temperature
with respect to the GPM of cooling water flowing through the cooling jacket surrounding the seal chamber.

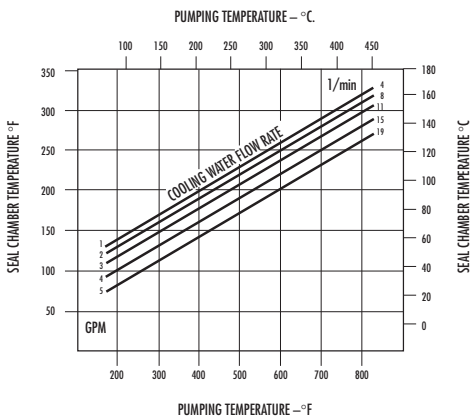

*GPM Flow Rate of Cooling Water Based on 70°F (21°C) Inlet Temp
Specifications are subject to change without notice

STANDARD MATERIALS OF CONSTRUCTION				
Part No.	Part Name	Carbon Steel w/ C.I. Trim (C.I. 40)	Carbon Steel w/ 11-13 Cr. Trim (C.I. 41)	316 SS (C.I. 50)
3	Impeller	C.I. (1)	11-13 Cr. (17)	316 (3)
*4	Impeller Key	Steel (2)	Steel (2)	316 (8)
5	Casing	Steel (6)	Steel (6)	316 (3)
5A	Casing Drain Plug	Steel (2)	Steel (2)	316 (8)
5C	Casing Stud Nut	Steel (5)	Steel (5)	Steel (5)
5D	Casing Stud	Steel (4)	Steel (4)	Steel (4)
*6	Casing Back Cover Ring	Iron (7)	11-13 Cr. (18)	316 (3)
6A	Casing Ring	Iron (7)	11-13 Cr. (18)	316 (3)
7	Cradle Spacer	Steel (6)	Steel (6)	Steel (6)
7A	Automatic Oiler w/Bull's Eye Gauge	Alum/Glass	Alum/Glass	Alum/Glass
7G	Spacer to Bearing Housing Capscrew	Steel (2)	Steel (2)	Steel (2)
9	Bearing Housing Foot	C.I. (1)	C.I. (1)	C.I. (1)
*10	Shaft Sleeve	316 (8)	316 (8)	316 (8)
*10K	Shaft Sleeve Key	304 (9)	304 (9)	304 (9)
*12	Impeller Bolt (Nut on R5170)	Steel (2)	Steel (2)	316 (8)
*12A	Impeller Washer	Steel (2)	Steel (2)	316 (8)
*12B	Impeller Lock Washer	316 (8)	316 (8)	316 (8)
*12C	Impeller Washer Pin	304 (9)	304 (9)	316 (8)
13	Seal Chamber Gland	316 (8)	316 (8)	316 (8)
	Packing Gland	Steel (6)	Steel (6)	316 (3)
14	Gland Stud	Steel (4)	Steel (4)	304 (9)
15	Gland Nut	Steel (5)	Steel (5)	304 (9)
*17	Lantern Ring	C.I. (1)	C.I. (1)	316 (3)
22	Casing Back Cover	Steel (6)	Steel (6)	316 (3)
*22A	Back Cover to Cradle Cap Screw	Steel (2)	Steel (2)	Steel (2)
*25	Radial Bearing	Steel	Steel	Steel
*25A	Thrust Bearing	Steel	Steel	Steel
*26	Bearing Housing	C.I. (1)	C.I. (1)	C.I. (1)
*27	Seal Ring	C.I. (1)	C.I. (1)	C.I. (1)
*28	Bearing End Cover	C.I. (1)	C.I. (1)	C.I. (1)
*28A	Bearing End Cover Cap Screw	Steel (2)	Steel (2)	Steel (2)
*29	Pump Shaft	Steel (10)	Steel (10)	316 (8)
*31	Thrust Bearing Lock Nut	Steel (2)	Steel (2)	Steel (2)
*31A	Thrust Bearing Lock Washer	Steel (2)	Steel (2)	Steel (2)
*54	Throat Bushing	C.I. (1)	11-13 Cr. (19)	316 (8)
56	Casing Foot	C.I. (1)	C.I. (1)	C.I. (1)
*56B	Casing Foot Dowel	Steel (2)	Steel (2)	Steel (2)
*75B	Retaining Ring (All Except R5240)	Steel	Steel	Steel
*76	Labyrinth Seal—Front	Bronze & Vitan†	Bronze & Vitan†	Bronze & Vitan†
*76A	Labyrinth Seal—Rear	Bronze & Vitan†	Bronze & Vitan†	Bronze & Vitan†
77	Casing Gasket—Spiral Wound	316 & Grafal (11)	316 & Grafal (11)	316 & Grafal (11)
*77B	End Cover Gasket	Buna (14)	Buna (14)	Buna (14)
*80	Bearing Housing Vent	Steel	Steel	Steel
*87	Impeller Ring—Back	Steel (2)	11-13 Cr. (20)	316 (3)
87A	Impeller Ring—Front	Steel (2)	11-13 Cr. (20)	316 (3)
95A	Mechanical Seal Stationary	—	—	—
95B	Mechanical Seal Rotary	—	—	—
*109	Oil Cooler—(SS Tubing with Steel Fins)	SS & Steel	SS & Steel	SS & Steel
302	Throttle Bushing—Gland	Carbon	Carbon	Carbon

MATERIAL SPECIFICATIONS (REFER TO NUMBERS IN PARENTHESES)

- (1) Cast Iron
- (2) AISI 1020
- (3) 316SS — ASTM #A744 Grade CF8M
- (4) AISI 4140, ASTM #A193-B7 Steel
- (5) ASTM #A194 Grade 2 Steel
- (6) ASTM #A216 Grade WCB Cast Steel (-20 + 800°F)
- (7) Hardened Iron
- (8) AISI—316SS
- (9) AISI—304SS
- (10) Alloy Steel —125,000 TS, 100,000 YP
- (11) Grafal — Registered trademark of Union Carbide Corp.
- (12) Manila Paper
- (13) Fibre Sheet — Non-Asbestos Fibre
- (14) Buna N Rubber
- (15) Steel Fitted, Stainless Steel Tube with Steel End Fittings
- (16) Ductile Iron — ASTM-A536 Class 65-45-12
- (17) ASTM A743 Grade CA15 or Grade CA6NM
- (18) ASTM A743 Grade CA40 Hardened to 475/525 Brinell
- (19) AISI — 420 Stainless Steel
- (20) ASTM A743 Grade CA40

SEAL CHAMBER PRESSURE - R5000 SERIES PUMPS

**With Impeller Balance Holes—Seal Chamber Pressure Equals Pump Suction Pressure Plus .06 x Pump Developed Pressure in PSI
 Without Impeller Balance Holes—Seal Chamber Pressure Equals Pump Suction Pressure Plus .75 x Pump Developed Pressure in PSI
 Pumps are normally furnished with balance holes

R5000 Series Pumps — Allowable Working Pressure VS Pumping Temperature

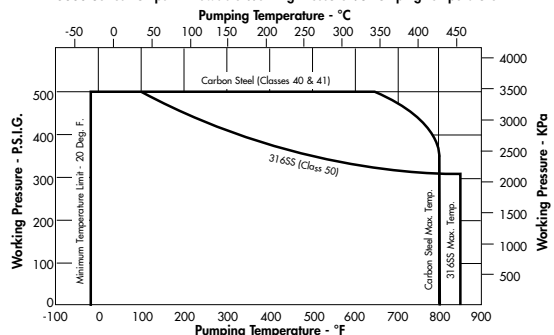

† Registered trademark of the E.I. DuPont Co.
 * Denotes parts interchangeable in all pump sizes of same type.

**R5140 CROSS SECTION
WITH SEAL CHAMBER**

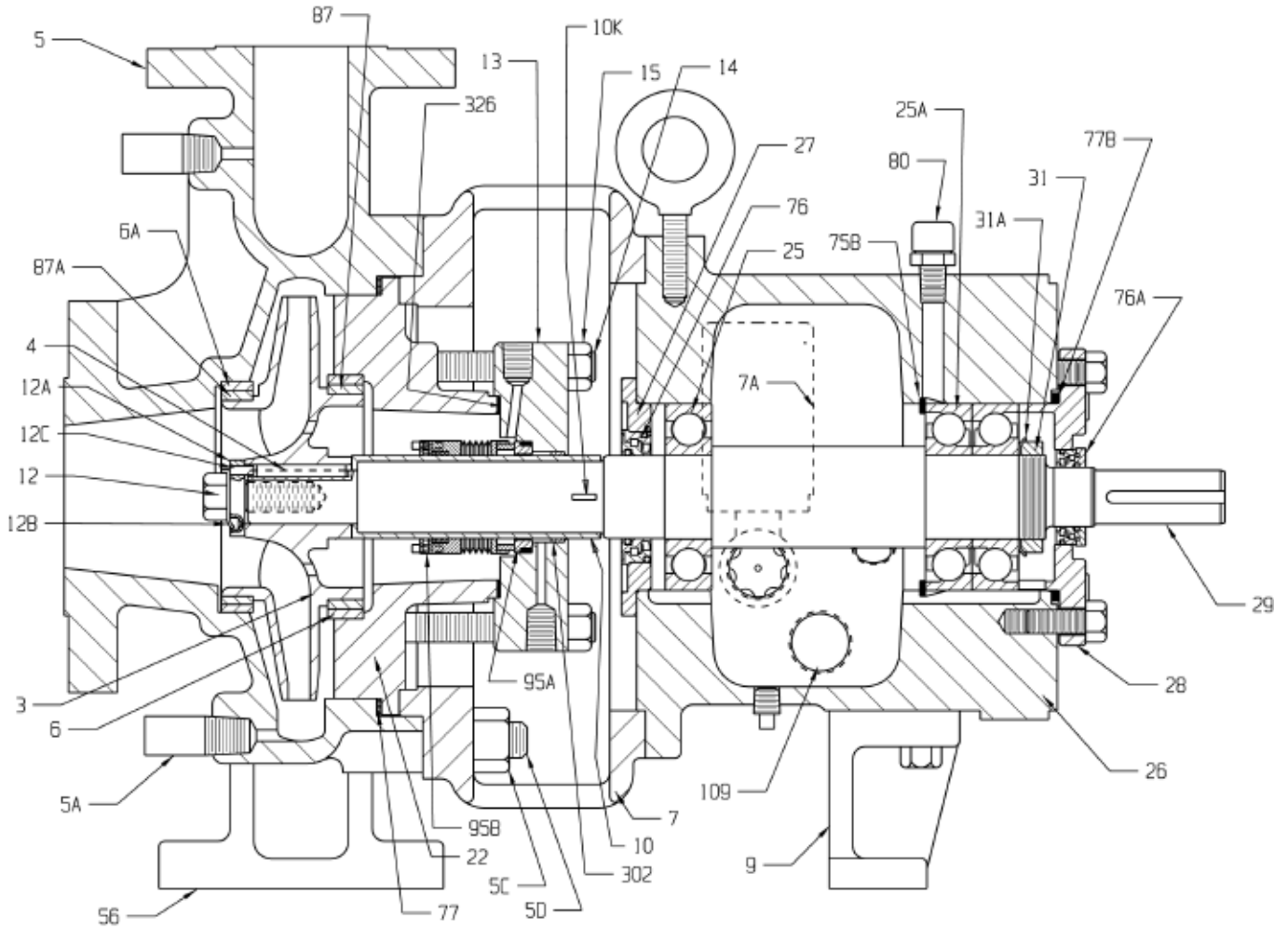

R5140 CROSS SECTION
WITH COOLED STUFFING BOX

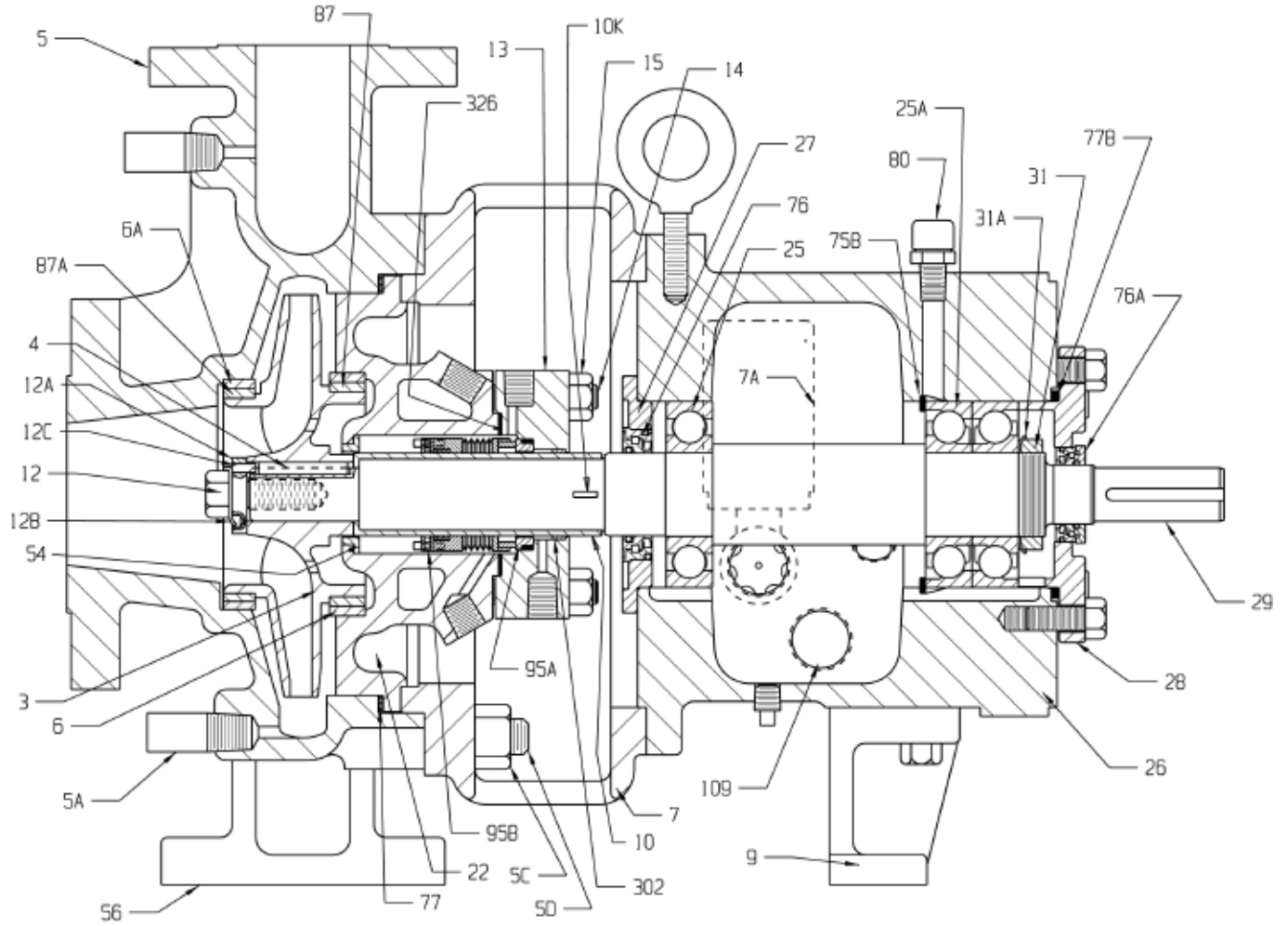

**R5170 CROSS SECTION
WITH COOLED STUFFING BOX**

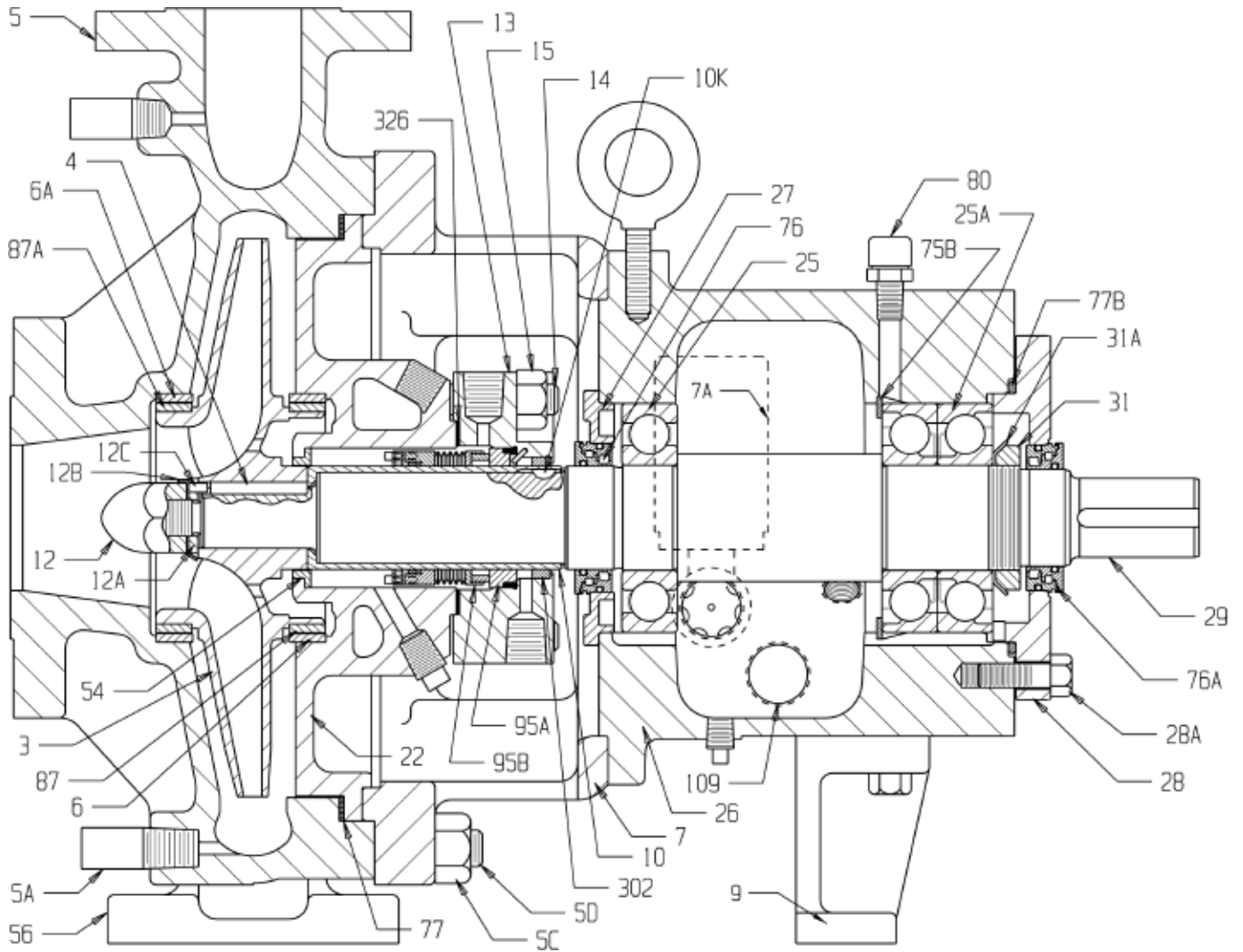

R5180 CROSS SECTION
WITH COOLED STUFFING BOX

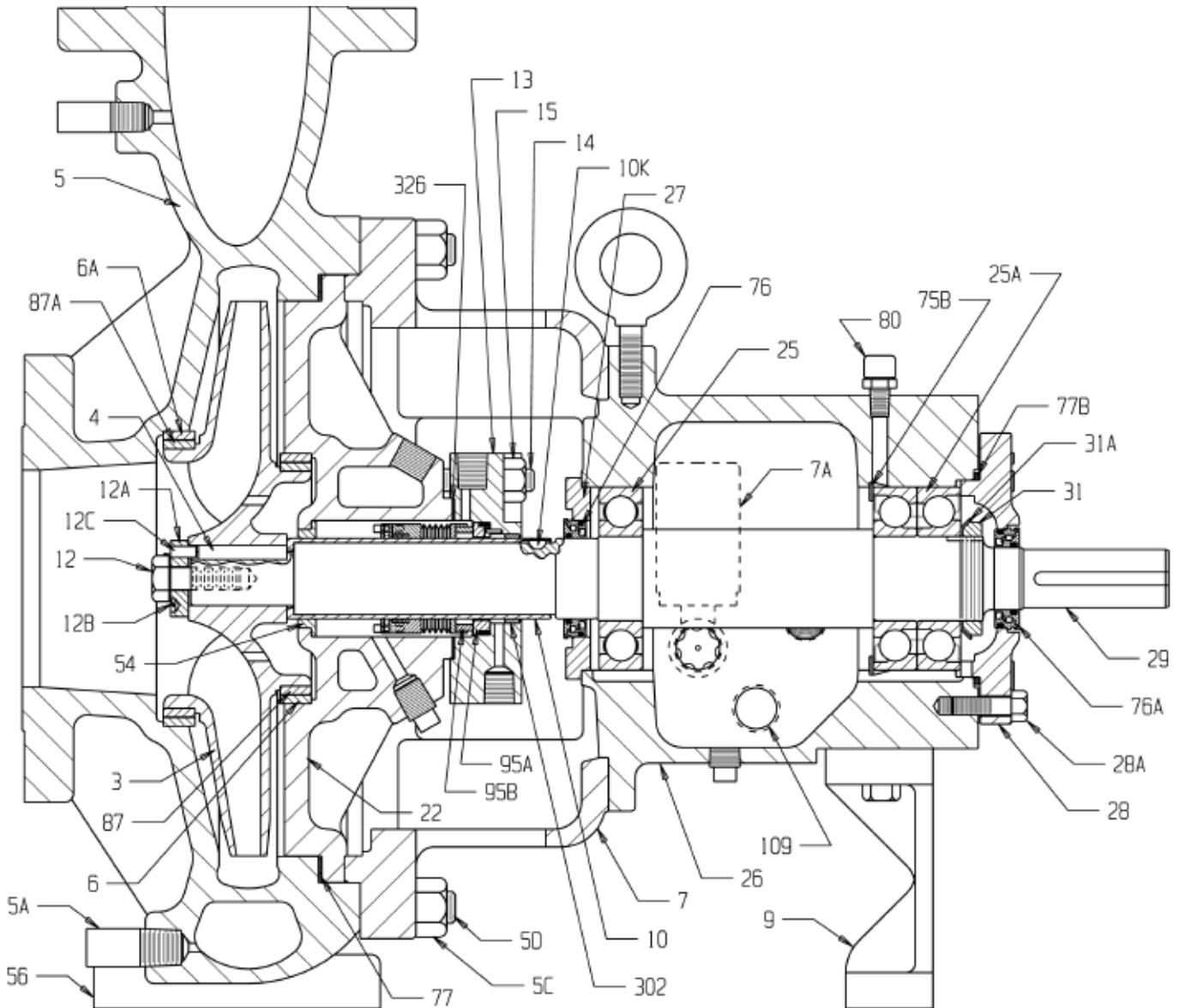

STANDARD, END SUCTION, CLOSED IMPELLER, CENTRIFUGAL PROCESS PUMP
TYPE R5140

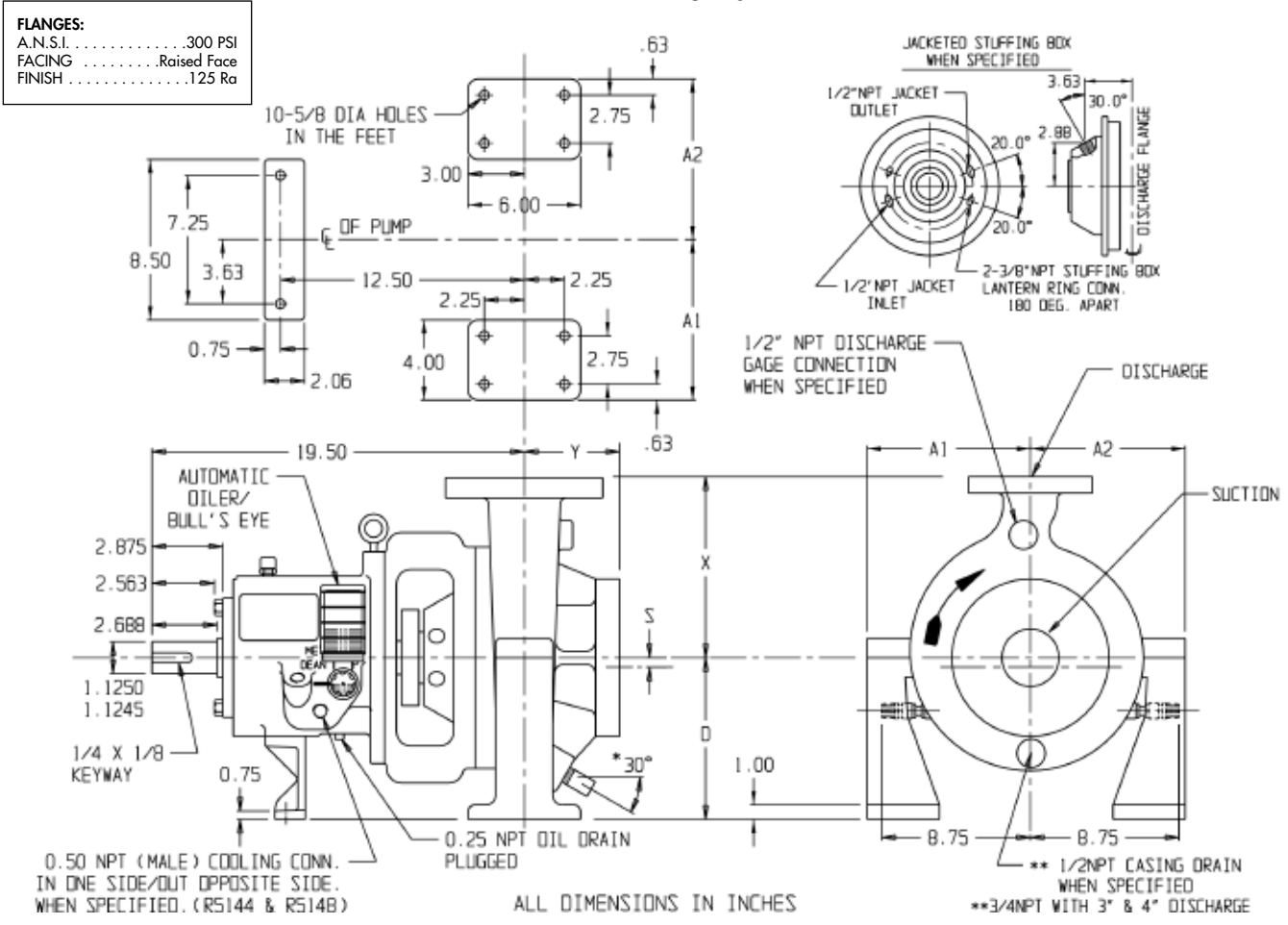

PUMP SIZE	DISCHARGE					SUCTION					A ₁	A ₂	D	S	X	Y
	SIZE	O.D.	THK	B.C.	BOLTS	SIZE	O.D.	THK	B.C.	BOLTS						
*1 x 3 x 8 1/2	1	47/8	11/16	3 1/2	4-5/8	3	8 1/4	1 1/8	65/8	8-3/4	8 1/8	8 1/8	8 1/4	0	7 1/2	4
1 1/2 x 3 x 8 1/2	1 1/2	6 1/8	13/16	4 1/2	4-3/4	3	8 1/4	1 1/8	65/8	8-3/4	8 1/8	8 1/8	8 1/4	0	8 1/2	4
2 x 3 x 8 1/2	2	6 1/2	7/8	5	8-5/8	3	8 1/4	1 1/8	65/8	8-3/4	8 1/8	8 1/8	8 1/4	0	9 1/2	5
*3 x 4 x 8 1/2	3	8 1/4	1 1/8	65/8	8-3/4	4	10	1 1/4	77/8	8-3/4	9	8 1/8	10	0	11	5
*4 x 6 x 8 1/2	4	10	1 1/4	77/8	8-3/4	6	12 1/2	17/16	105/8	12-3/4	10 1/4	8 1/8	10	5/8	11 1/2	6
1 1/2 x 3 x 10	1 1/2	6 1/8	13/16	4 1/2	4-3/4	3	8 1/4	1 1/8	65/8	8-3/4	9	8 3/4	10	0	9	4
2 x 3 x 10	2	6 1/2	7/8	5	8-5/8	3	8 1/4	1 1/8	65/8	8-3/4	9	8 3/4	10	0	9 1/2	5
3 x 4 x 10	3	8 1/4	1 1/8	65/8	8-3/4	4	10	1 1/4	77/8	8-3/4	10 3/8	8 3/4	10	0	11	5
4 x 6 x 10 #2	4	10	1 1/4	77/8	8-3/4	6	12 1/2	17/16	105/8	12-3/4	11 3/4	10	11 1/2	1/8	12 1/2	6
1 x 2 x 11 1/2	1	47/8	11/16	3 1/2	4-5/8	2	6 1/2	7/8	5	8-5/8	9 3/4	9 3/4	10	0	9	5
1 1/2 x 3 x 11 1/2	1 1/2	6 1/8	13/16	4 1/2	4-3/4	3	8 1/4	1 1/8	65/8	8-3/4	9 3/4	9 3/4	10	0	10 1/2	4
2 x 3 x 11 1/2	2	6 1/2	7/8	5	8-5/8	3	8 1/4	1 1/8	65/8	8-3/4	10 1/4	9 3/4	10	0	10 1/2	5
3 x 4 x 11 1/2	3	8 1/4	1 1/8	65/8	8-3/4	4	10	1 1/4	77/8	8-3/4	11 1/4	10	11 1/2	0	12 1/2	6
4 x 6 x 11 1/2	4	10	1 1/4	77/8	8-3/4	6	12 1/2	17/16	105/8	12-3/4	11 3/4	10 1/2	11 1/2	3/8	13 1/2	6
1 1/2 x 3 x 13 1/2	1 1/2	6 1/8	13/16	4 1/2	4-3/4	3	8 1/4	1 1/8	65/8	8-3/4	11 1/2	11 1/2	11 1/2	0	11	5
2 x 3 x 13 1/2	2	6 1/2	7/8	5	8-5/8	3	8 1/4	1 1/8	65/8	8-3/4	11 1/2	11 1/2	11 1/2	0	11 1/2	5
3 x 4 x 13 1/2	3	8 1/4	1 1/8	65/8	8-3/4	4	10	1 1/4	77/8	8-3/4	12	11 1/2	11 1/2	0	12 1/2	6

All dimensions in inches

IMPORTANT: DO NOT USE FOR CONSTRUCTION UNLESS CERTIFIED.

DIMENSION DWG.
NO. R-1009

(317) 293-2930 • E-mail: info@deanpump.com

STANDARD, END SUCTION, CLOSED IMPELLER, CENTRIFUGAL PROCESS PUMP
TYPE R5140 WITH REFINERY TYPE BASE

FLANGES:
A.N.S.I.300 PSI
FACINGRaised Face
FINISH125 Ra

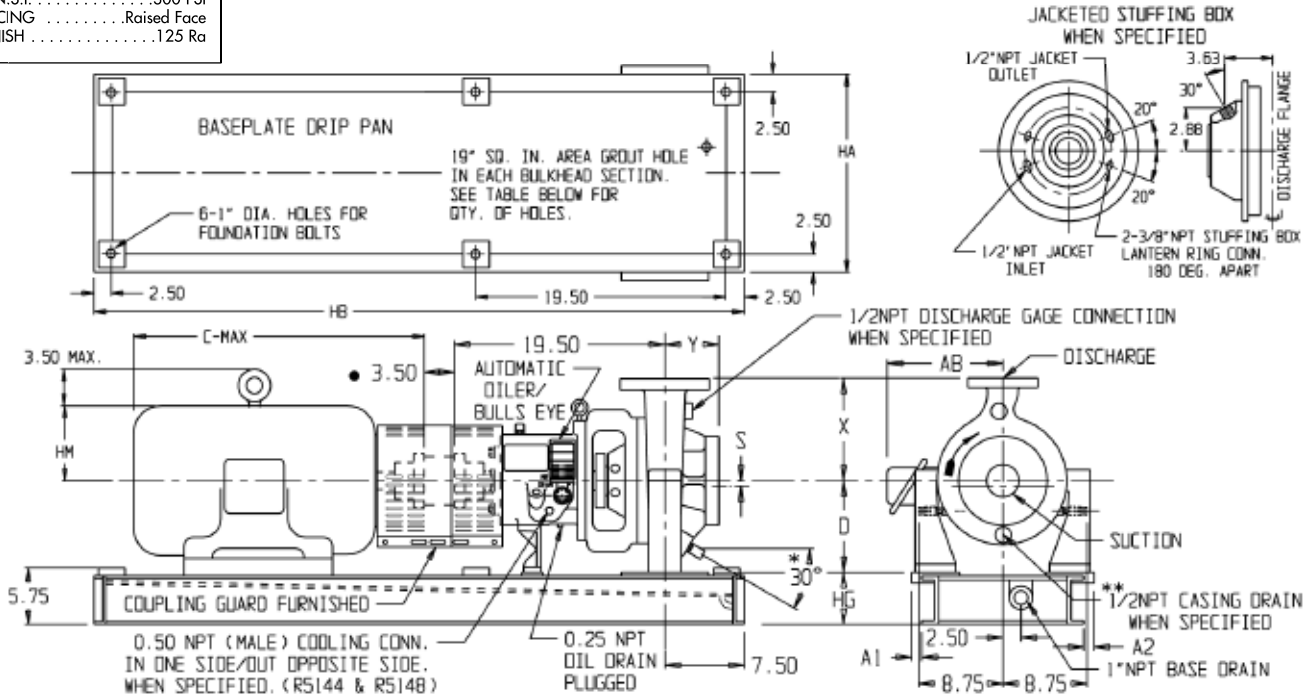

PUMP SIZE	DISCHARGE				SUCTION				A ₁	A ₂	D	S	X	Y		
	SIZE	O.D.	THK	B.C.	BOLTS	SIZE	O.D.	THK							B.C.	BOLTS
*1 x 3 x 8 1/2	1	47/8	1 1/16	3 1/2	4-5/8	3	8 1/4	1 1/8	6 5/8	8-3/4	0	0	8 1/4	0	7 1/2	4
1 1/2 x 3 x 8 1/2	1 1/2	6 1/8	1 3/16	4 1/2	4-3/4	3	8 1/4	1 1/8	6 5/8	8-3/4	0	0	8 1/4	0	8 1/2	4
2 x 3 x 8 1/2	2	6 1/2	7/8	5	8-5/8	3	8 1/4	1 1/8	6 5/8	8-3/4	0	0	8 1/4	0	9 1/2	5
*3 x 4 x 8 1/2	3	8 1/4	1 1/8	6 5/8	8-3/4	4	10	1 1/4	7 7/8	8-3/4	0	3/8	10	0	11	5
*4 x 6 x 8 1/2	4	10	1 1/4	7 7/8	8-3/4	6	12 1/2	1 7/16	10 5/8	12-3/4	0	3/8	10	5/8	11 1/2	6
1 1/2 x 3 x 10	1 1/2	6 1/8	1 3/16	4 1/2	4-3/4	3	8 1/4	1 1/8	6 5/8	8-3/4	0	3/8	10	0	9	4
2 x 3 x 10	2	6 1/2	7/8	5	8-5/8	3	8 1/4	1 1/8	6 5/8	8-3/4	0	3/8	10	0	9 1/2	5
3 x 4 x 10	3	8 1/4	1 1/8	6 5/8	8-3/4	4	10	1 1/4	7 7/8	8-3/4	0	3/8	10	0	11	5
4 x 6 x 10 #2	4	10	1 1/4	7 7/8	8-3/4	6	12 1/2	1 7/16	10 5/8	12-3/4	1/4	1	11 1/2	1/8	12 1/2	6
1 x 2 x 11 1/2	1	47/8	1 1/16	3 1/2	4-5/8	2	6 1/2	7/8	5	8-5/8	0	3/8	10	0	9	5
1 1/2 x 3 x 11 1/2	1 1/2	6 1/8	1 3/16	4 1/2	4-3/4	3	8 1/4	1 1/8	6 5/8	8-3/4	0	3/8	10	0	10 1/2	4
2 x 3 x 11 1/2	2	6 1/2	7/8	5	8-5/8	3	8 1/4	1 1/8	6 5/8	8-3/4	0	3/8	10	0	10 1/2	5
3 x 4 x 11 1/2	3	8 1/4	1 1/8	6 5/8	8-3/4	4	10	1 1/4	7 7/8	8-3/4	1/4	1	11 1/2	0	12 1/2	6
4 x 6 x 11 1/2	4	10	1 1/4	7 7/8	8-3/4	6	12 1/2	1 7/16	10 5/8	12-3/4	1/4	1	11 1/2	3/8	13 1/2	6
1 1/2 x 3 x 13 1/2	1 1/2	6 1/8	1 3/16	4 1/2	4-3/4	3	8 1/4	1 1/8	6 5/8	8-3/4	1/4	1	11 1/2	0	11	5
2 x 3 x 13 1/2	2	6 1/2	7/8	5	8-5/8	3	8 1/4	1 1/8	6 5/8	8-3/4	1/4	1	11 1/2	0	11 1/2	5
3 x 4 x 13 1/2	3	8 1/4	1 1/8	6 5/8	8-3/4	4	10	1 1/4	7 7/8	8-3/4	1/4	1	11 1/2	0	12 1/2	6

FRAME	C	AB	HA			HB	HG		HM	Qty. of Grout Holes	
			D=8 1/4	D=10	D=11 1/2		D=8 1/4	D=10 & 11 1/2		D=8 1/4	D=10 & 11 1/2
143T	13 1/4	6 1/2	18	21	23	50	5 1/8	5 1/8	3 7/8	3	3
145T	13 3/4	6 1/2	18	21	23	50	5 1/8	5 1/8	3 7/8	3	3
182T	14 5/8	7 1/2	18	21	23	50	5 1/8	5 1/8	5 1/4	3	3
184T	15 5/8	7 1/2	18	21	23	50	5 1/8	5 1/8	5 1/4	3	3
213T	18 1/8	9 1/2	18	21	23	50	5 1/8	5 1/8	6	3	3
215T	19 5/8	9 1/2	18	21	23	50	5 1/8	5 1/8	6	3	3
254T	23 1/8	10 3/4	21	21	23	58	5 1/8	5 1/8	7	4	4
256T	24 7/8	10 3/4	21	21	23	58	5 1/8	5 1/8	7	4	4
284T	26 7/8	12 5/8	21	21	23	58	5 1/8	5 1/8	7 3/4	4	4
284TS	25 1/2	12 5/8	21	21	23	58	5 1/8	5 1/8	7 3/4	4	4
286T	28 3/8	12 5/8	21	21	23	58	5 1/8	5 1/8	7 3/4	4	4

FRAME	C	AB	HA			HB	HG		HM	Qty. of Grout Holes	
			D=8 1/4	D=10	D=11 1/2		D=8 1/4	D=10 & 11 1/2		D=8 1/4	D=10 & 11 1/2
286TS	27	12 5/8	21	21	23	58	5 1/8	5 1/8	7 3/4	4	4
324T	29 7/8	14 3/4	18	22	23	62	6 3/8	5 1/8	8 3/4	3	4
324TS	28 3/8	14 3/4	18	22	23	62	6 3/8	5 1/8	8 3/4	3	4
326T	31 3/8	14 3/4	18	22	23	62	6 3/8	5 1/8	8 3/4	3	4
326TS	29 7/8	14 3/4	18	22	23	62	6 3/8	5 1/8	8 3/4	3	4
364T	33 1/8	15 5/8	18	22	23	62	6 3/8	5 1/8	9 7/8	3	4
364TS	31 1/2	15 5/8	18	22	23	62	6 3/8	5 1/8	9 7/8	3	4
365T	34 1/8	15 5/8	18	22	23	62	6 3/8	5 1/8	9 7/8	3	4
365TS	32 1/2	15 5/8	18	22	23	62	6 3/8	5 1/8	9 7/8	3	4
405TS	38 1/2	19 3/4	20	24	25	68	6 3/8	5 1/8	11	3	4
444TS	45	21 1/2	22	26	27	76	6 3/8	5 1/8	12 1/4	3	4

All dimensions in inches

** 3/4 NPT with 3" & 4" discharge

• Spacer is 5" for motor frames 405TS and 444TS

IMPORTANT: DO NOT USE FOR CONSTRUCTION UNLESS CERTIFIED.

DIMENSION DWG.
NO. R-1041

STANDARD, END SUCTION, CLOSED IMPELLER, CENTRIFUGAL PROCESS PUMP
TYPE R5170

FLANGES:
A.N.S.I. CLASS300
FACINGRaised Face
FINISH125 Ra

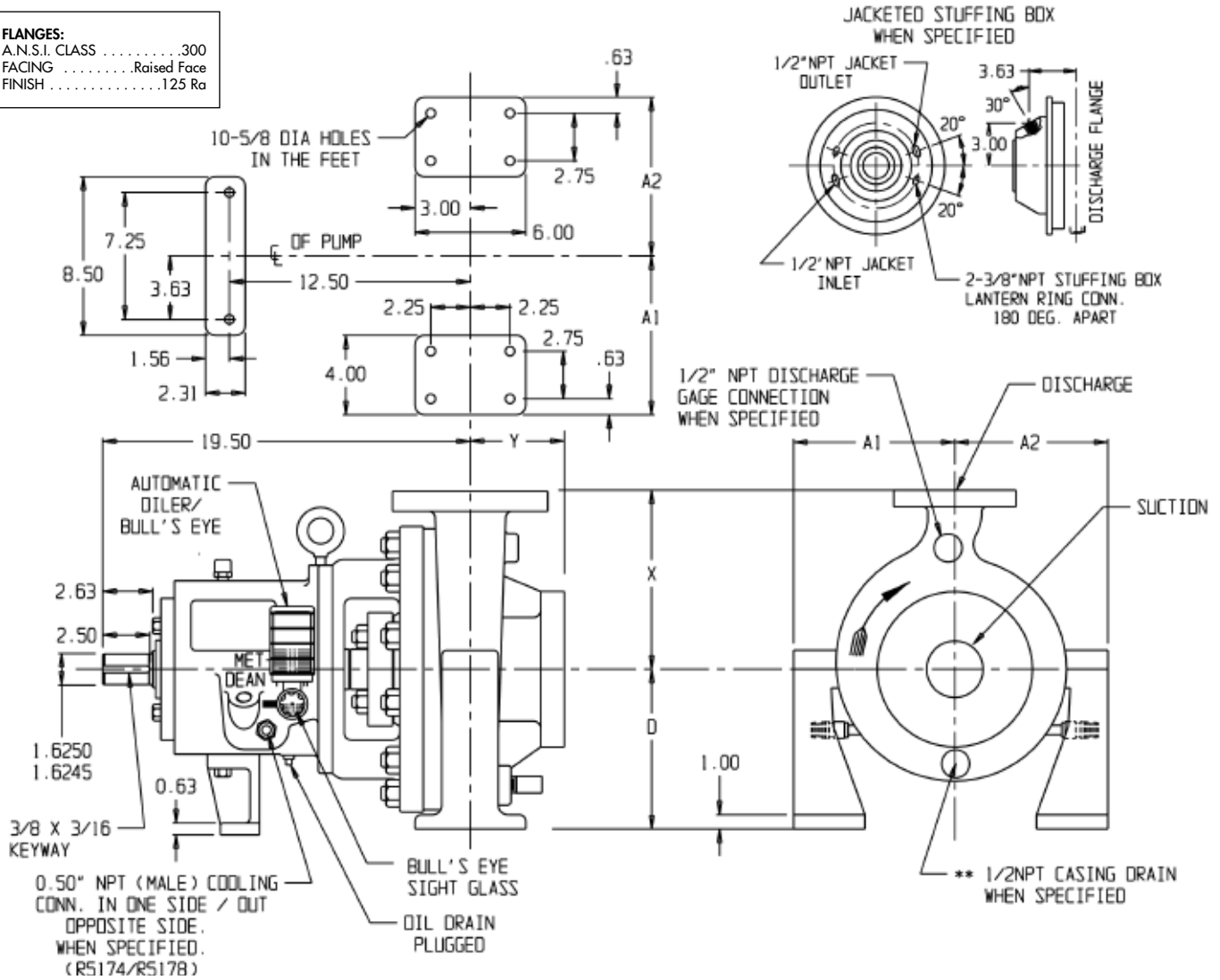

* 3/4 NPT with 3" & 4" discharge

PUMP SIZE	DISCHARGE					SUCTION					A ₁	A ₂	D	X	Y
	SIZE	O.D.	THK	B.C.	BOLTS	SIZE	O.D.	THK	B.C.	BOLTS					
1 1/2 x 3 x 13 1/2	1 1/2	6 1/8	1 3/16	4 1/2	4-3/4	3	8 1/4	1 1/8	6 5/8	8-3/4	11 1/2	11 1/2	11 1/2	11	5
2 x 3 x 13 1/2	2	6 1/2	7/8	5	8-5/8	3	8 1/4	1 1/8	6 5/8	8-3/4	11 1/2	11 1/2	11 1/2	11 1/2	5
3 x 4 x 13 1/2	3	8 1/4	1 1/8	6 5/8	8-3/4	4	10	1 1/4	7 7/8	8-3/4	12	11 1/2	11 1/2	12 1/2	6

All dimensions in inches

IMPORTANT: DO NOT USE FOR CONSTRUCTION UNLESS CERTIFIED.

DIMENSION DWG.
NO. R-4009

(317) 293-2930 • E-mail: info@deanpump.com

STANDARD, END SUCTION, CLOSED IMPELLER, CENTRIFUGAL PROCESS PUMP
TYPE R5170 WITH REFINERY TYPE BASE

FLANGES:
A.N.S.I.Class 300
FACINGRaised Face
FINISH125 Ra

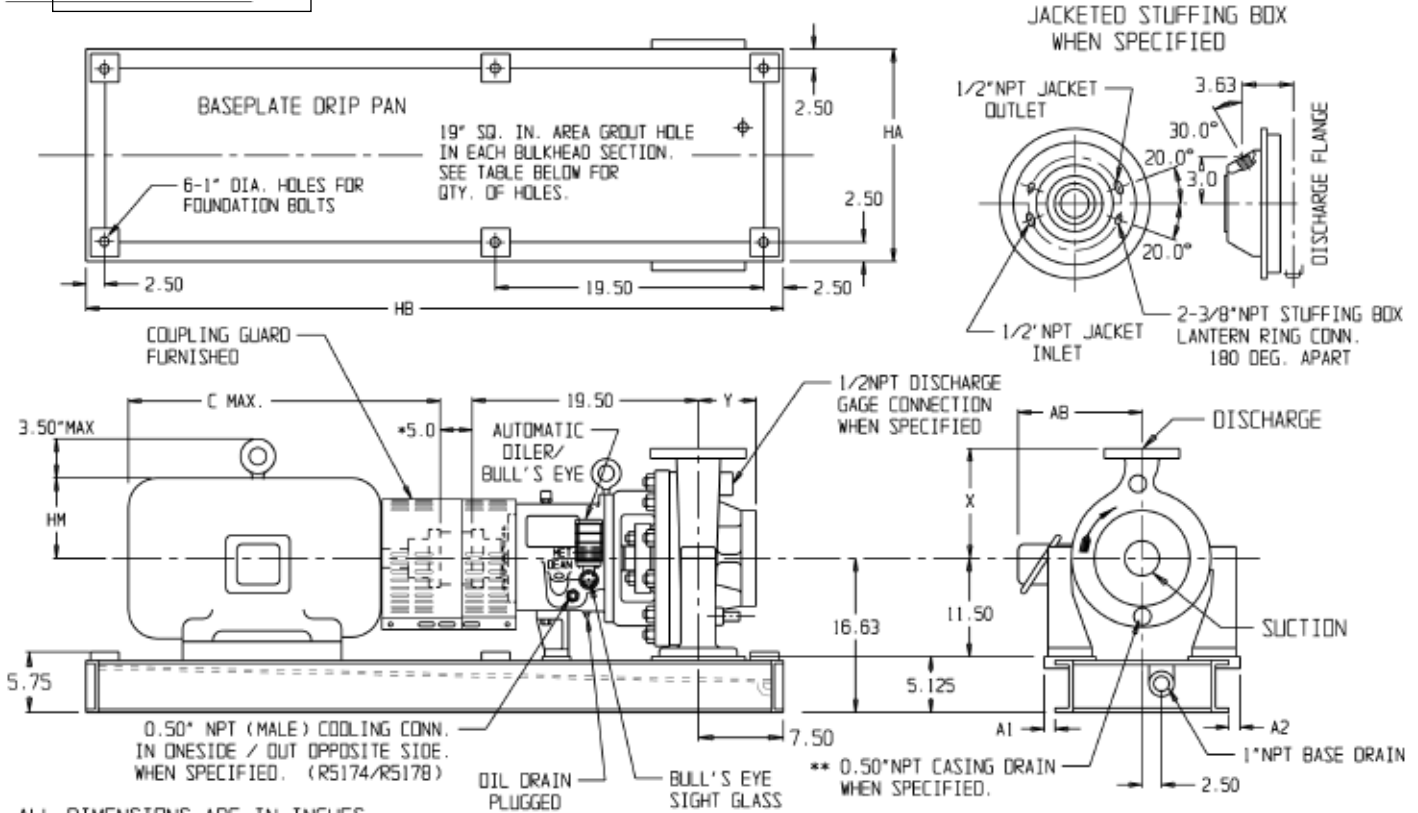

ALL DIMENSIONS ARE IN INCHES

* FOR HORSEPOWER BELOW 40 @ 1750 AND 100 @ 3500 RPM THE SPACER IS 3.50

* 3/4 NPT with 3" & 4" discharge

PUMP SIZE	DISCHARGE					SUCTION					A ₁	A ₂	X	Y
	SIZE	O.D.	THK	B.C.	BOLTS	SIZE	O.D.	THK	B.C.	BOLTS				
1 1/2 x 3 x 13 1/2	1 1/2	6 1/8	1 3/16	4 1/2	4-3/4	3	8 1/4	1 1/8	6 5/8	8-3/4	1	1/4	11	5
2 x 3 x 13 1/2	2	6 1/2	7/8	5	8-5/8	3	8 1/4	1 1/8	6 5/8	8-3/4	1	1/4	11 1/2	5
3 x 4 x 13 1/2	3	8 1/4	1 1/8	6 5/8	8-3/4	4	10	1 1/4	7 7/8	8-3/4	1	1/4	12 1/2	6

All dimensions in inches

* For Horsepower below 40 @ 1750 and 100 @ 3500 RPM the spacer is 3 1/2".

FRAME	C	AB	HA	HB	HM	QTY. OF GROUT HOLES
254T	22 7/8	11	23	58	7	4
256T	24 3/4	11	23	58	7	4
284T	26 3/4	12 3/4	23	58	7 3/4	4
284TS	25 1/4	12 3/4	23	58	7 3/4	4
286T	28 1/4	12 3/4	23	58	7 3/4	4
286TS	26 3/4	12 3/4	23	58	7 3/4	4
324T	29 3/4	14 3/4	23	62	8 3/4	4
324TS	28 1/4	14 3/4	23	62	8 1/4	4

FRAME	C	AB	HA	HB	HM	QTY. OF GROUT HOLES
326T	31 1/4	14 3/4	23	62	8 3/4	4
326TS	29 3/4	14 3/4	23	62	8 3/4	4
364TS	31 1/4	16 1/4	23	62	9 7/8	4
365TS	32 1/4	16 1/4	23	62	9 7/8	4
404TS	33 1/2	17 1/2	23	72	10 3/4	4
405TS	35	17 1/2	23	72	10 3/4	4
444TS	38 1/2	18 1/2	26	76	12 1/4	5
445TS	40 1/2	18 1/2	26	76	12 1/4	5

IMPORTANT: DO NOT USE FOR CONSTRUCTION UNLESS CERTIFIED.

DIMENSION DWG.
NO. R-4041

STANDARD, END SUCTION, CLOSED IMPELLER, CENTRIFUGAL PROCESS PUMP
TYPE R5180

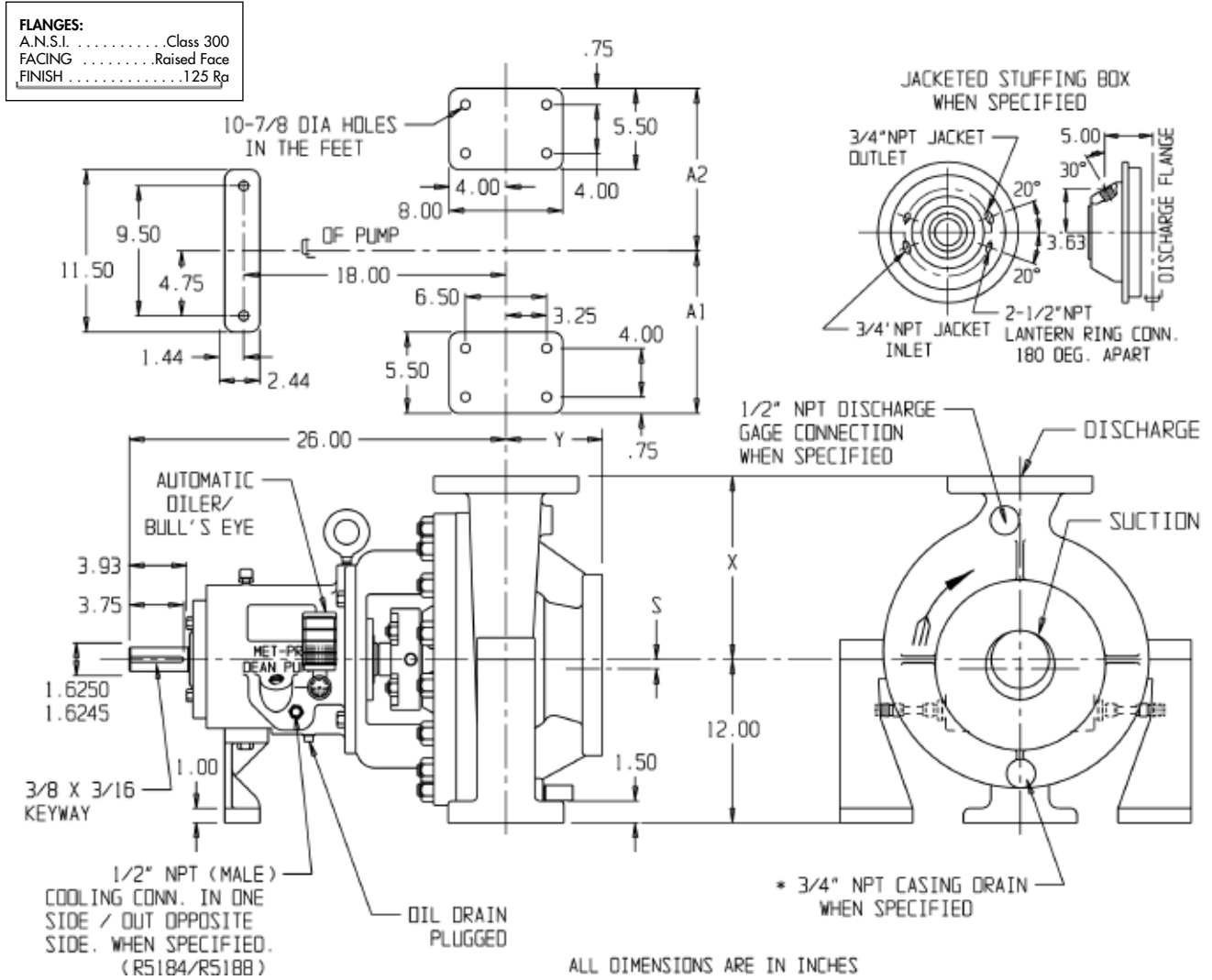

* 1/2 NPT with 2" discharge

PUMP SIZE	DISCHARGE					SUCTION					A ₁	A ₂	S	X	Y
	SIZE	O.D.	THK	B.C.	BOLTS	SIZE	O.D.	THK	B.C.	BOLTS					
4 x 6 x 10 #1	4	10	1 1/4	7 7/8	8-3/4	6	12 1/2	17 1/16	10 5/8	12-3/4	12 1/4	10 1/2	1/4	12	6
6 x 8 x 12 1/2	6	12 1/2	17 1/16	10 5/8	12-3/4	8	15	15 5/8	13	12-7/8	16 1/4	13	0	16 1/2	7
2 x 4 x 15 1/2	2	6 1/2	7/8	5	8-5/8	4	10	11 1/4	7 7/8	8-3/4	13 1/2	13 1/2	0	12 1/2	6
3 x 4 x 15 1/2	3	8 1/4	1 1/8	6 5/8	8-3/4	4	10	11 1/4	7 7/8	8-3/4	13 3/4	13 1/2	0	14	6
4 x 6 x 15 1/2	4	10	1 1/4	7 7/8	8-3/4	6	12 1/2	17 1/16	10 5/8	12-3/4	15 3/4	13 1/2	0	16	6

All dimensions in inches

STANDARD, END SUCTION, CLOSED IMPELLER, CENTRIFUGAL PROCESS PUMP
TYPE R5180 WITH REFINERY TYPE BASE

FLANGES:
A.N.S.I. Class 300
FACING Raised Face
FINISH 125 Ra

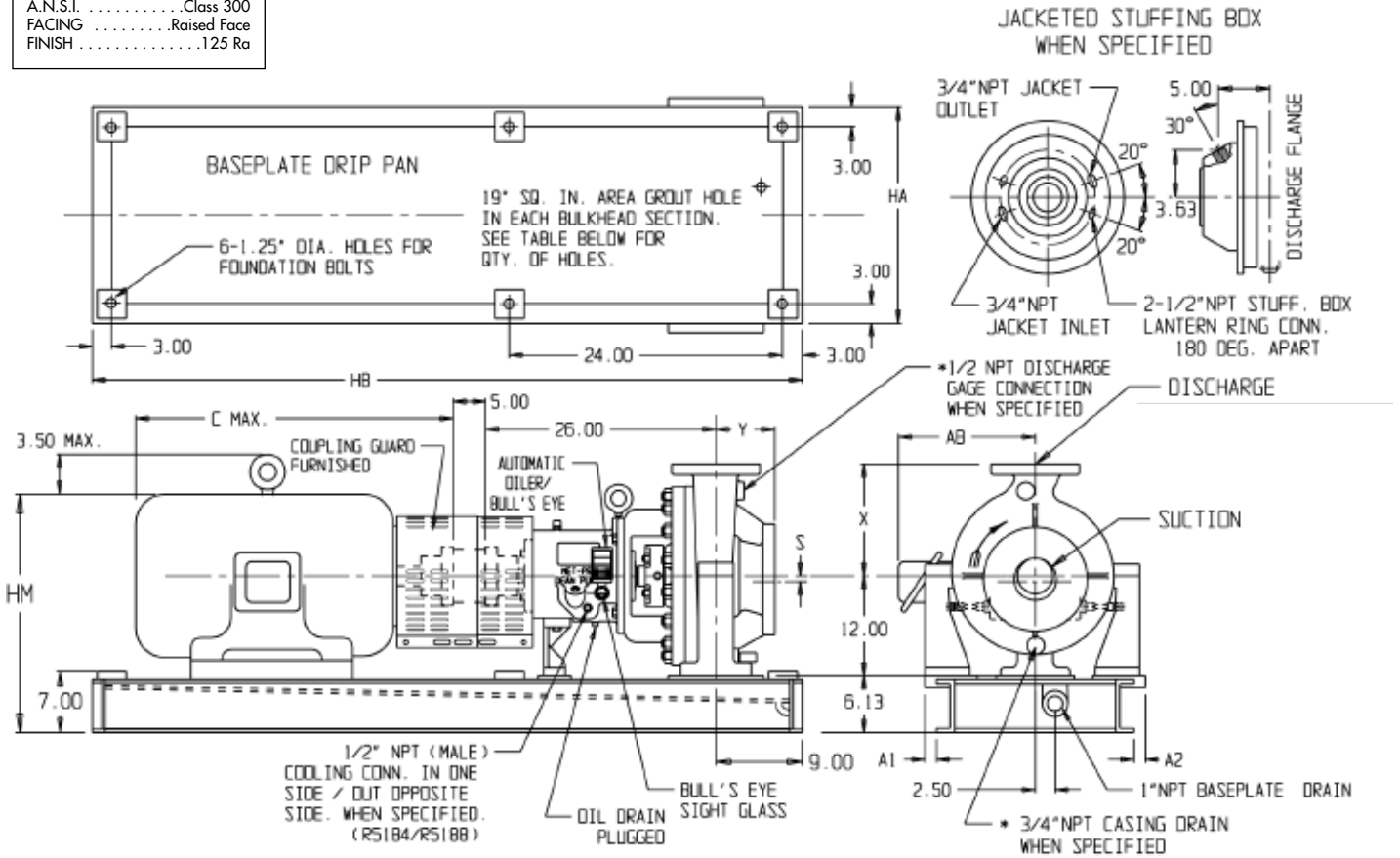

* 1/2 NPT with 2" discharge

PUMP SIZE	DISCHARGE					SUCTION					A ₁	A ₂	S	X	Y
	SIZE	O.D.	THK	B.C.	BOLTS	SIZE	O.D.	THK	B.C.	BOLTS					
4 x 6 x 10 #1	4	10	1 1/4	77/8	8-3/4	6	12 1/2	17/16	10 5/8	12-3/4	0	0	1/4	12	6
6 x 8 x 12 1/2	6	12 1/2	1 7/16	10 5/8	12-3/4	8	15	1 5/8	13	12-7/8	3/4	0	0	16 1/2	7
2 x 4 x 15 1/2	2	6 1/2	7/8	5	8-5/8	4	10	1 1/4	7 7/8	8-3/4	3/8	3/8	0	12 1/2	6
3 x 4 x 15 1/2	3	8 1/4	1 1/8	6 5/8	8-3/4	4	10	1 1/4	7 7/8	8-3/4	3/8	3/8	0	14	6
4 x 6 x 15 1/2	4	10	1 1/4	7 7/8	8-3/4	6	12 1/2	17/16	10 5/8	12-3/4	3/4	0	0	16	6

All dimensions in inches

FRAME	C	AB	HA			HB	HM	QTY. OF GROUT HOLES
			4x6x10 #1	2x4x15 1/2 3x4x15 1/2	6x8x12 1/2 4x6x15 1/2			
254T	227/8	11	26	28	32	68	247/8	3
256T	243/4	11	26	28	32	68	247/8	3
284T	263/4	12 3/4	26	28	32	68	25 5/8	3
286T	28 1/4	12 3/4	26	28	32	68	25 5/8	3
324TS	28 1/4	14 3/4	26	28	32	72	26 5/8	3
324T	29 3/4	14 3/4	26	28	32	72	26 5/8	3
326TS	29 3/4	14 3/4	26	28	32	72	26 5/8	3
326T	31 1/4	14 3/4	26	28	32	72	26 5/8	3
364TS	31 1/4	16 1/4	26	28	32	72	27 7/8	3

FRAME	C	AB	HA			HB	HM	QTY. OF GROUT HOLES
			4x6x10 #1	2x4x15 1/2 3x4x15 1/2	6x8x12 1/2 4x6x15 1/2			
364T	327/8	16 1/4	26	28	32	72	27 7/8	3
365TS	32 1/4	16 1/4	26	28	32	72	27 7/8	3
365T	33 7/8	16 1/4	26	28	32	72	27 7/8	3
404TS	33 1/2	17 1/2	26	28	32	78	28 7/8	5
404T	36 1/2	17 1/2	26	28	32	78	28 7/8	5
405TS	35	17 1/2	26	28	32	78	28 7/8	5
405T	38	17 1/2	26	28	32	78	28 7/8	5
444TS	38 1/2	18 1/2	26	28	32	82	30 3/8	5
445TS	40 1/2	18 1/2	26	28	32	82	30 3/8	5

IMPORTANT: DO NOT USE FOR CONSTRUCTION UNLESS CERTIFIED.

DIMENSION DWG.
NO. R-2041

**STANDARD, END SUCTION, CLOSED IMPELLER, CENTRIFUGAL PROCESS PUMP
TYPE R5240**

FLANGES:
A.N.S.I. Class 300
FACING Raised Face
FINISH 125 Ra

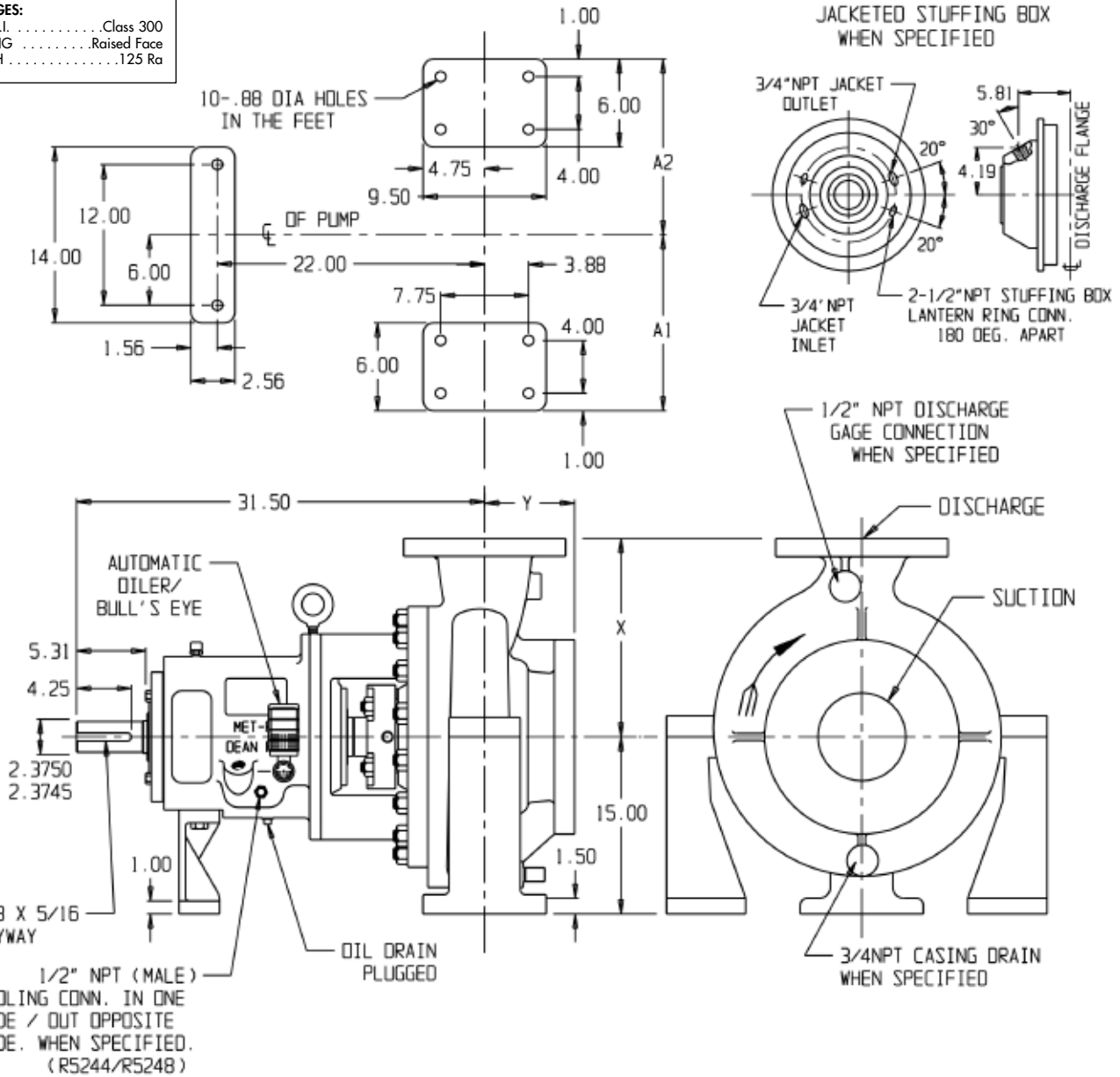

PUMP SIZE	DISCHARGE					SUCTION					A ₁	A ₂	X	Y
	SIZE	O.D.	THK	B.C.	BOLTS	SIZE	O.D.	THK	B.C.	BOLTS				
6 x 8 x 15 1/2	6	12 1/2	17 1/16	10 5/8	12-3/4	8	15	1 5/8	13	12-7/8	17 3/4	14 1/4	17 1/2	7
8 x 10 x 15 1/2	8	15	1 5/8	13	12-7/8	10	17 1/2	1 7/8	15 1/4	16-1	20	15 1/2	21	8

All dimensions in inches

IMPORTANT: DO NOT USE FOR CONSTRUCTION UNLESS CERTIFIED.

**DIMENSION DWG.
NO. R-3009**

STANDARD, END SUCTION, CLOSED IMPELLER, CENTRIFUGAL PROCESS PUMP
TYPE R5240 WITH REFINERY TYPE BASE

FLANGES:
A.N.S.I.Class 300
FACINGRaised Face
FINISH125 Ra

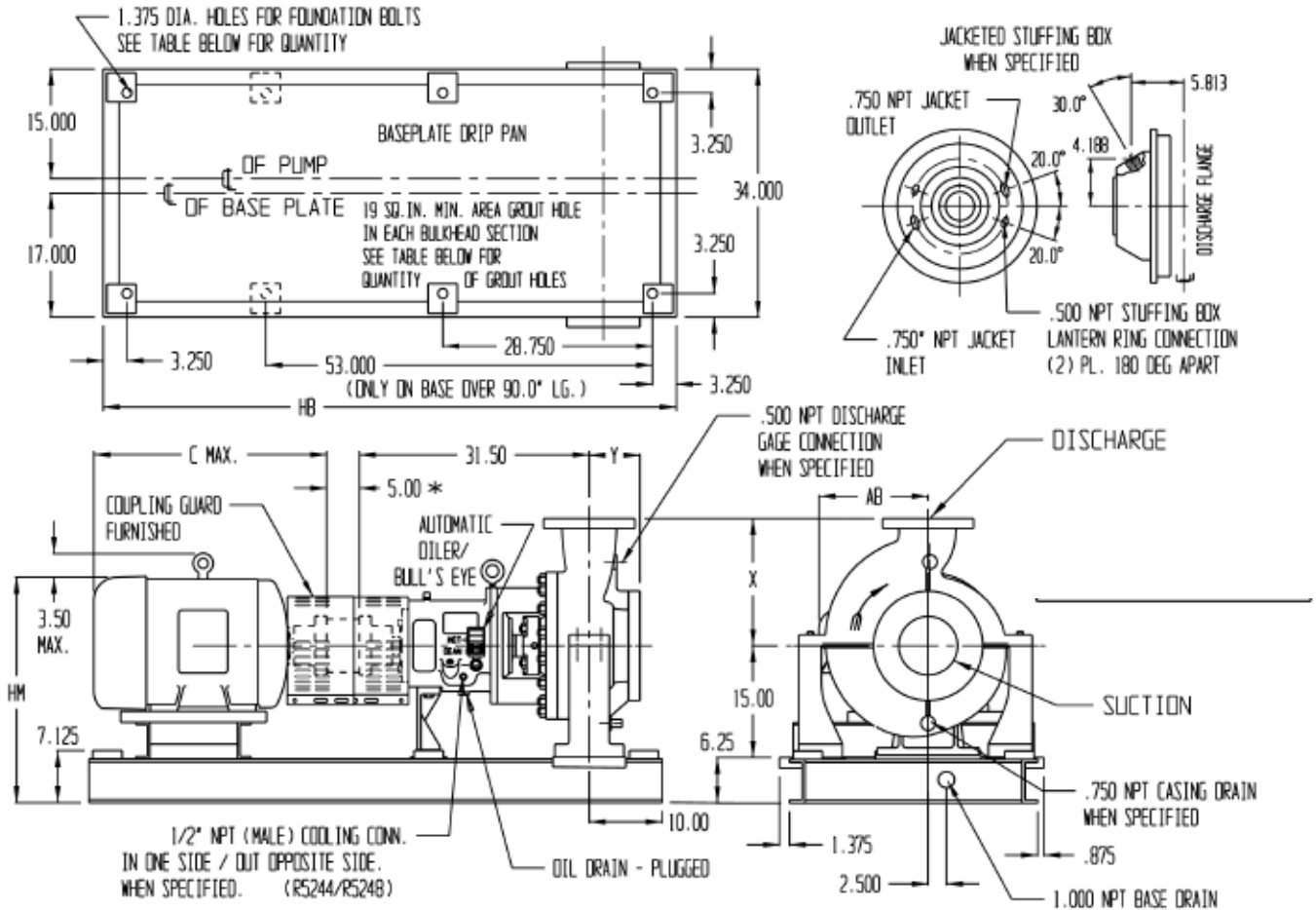

ALL DIMENSIONS ARE IN INCHES

PUMP SIZE	DISCHARGE					SUCTION					X	Y
	SIZE	O.D.	THK	B.C.	BOLTS	SIZE	O.D.	THK	B.C.	BOLTS		
6 x 8 x 15 1/2	6	12 1/2	1 7/16	10 5/8	12-3/4	8	15	1 5/8	13	12-7/8	17 1/2	7
8 x 10 x 15 1/2	8	15	1 5/8	13	12-7/8	10	17 1/2	1 7/8	15 1/4	16-1	21	8

All dimensions in inches

FRAME	C	AB	HB	HM	QTY. OF GROUT HOLES	QTY. OF FOUNDATION BOLT HOLES
254T	22 7/8	11	74	28 1/4	4	6
256T	24 3/4	11	74	28 1/4	4	6
284T	26 3/4	12 3/4	74	29	4	6
286T	28 1/4	12 3/4	74	29	4	6
324T	29 3/4	14 3/4	78	29 3/4	4	6
326T	31 1/2	14 3/4	78	29 3/4	4	6
364T	32 7/8	16 1/4	78	31	4	6
364TS	31 1/4	16 1/4	78	31	4	6
365T	33 7/8	16 1/4	78	31	4	6
365TS	32 1/4	16 1/4	78	31	4	6

FRAME	C	AB	HB	HM	QTY. OF GROUT HOLES	QTY. OF FOUNDATION BOLT HOLES
404T	36 1/2	17 1/2	86	32	4	6
404TS	33 1/2	17 1/2	86	32	4	6
405T	38	17 1/2	86	32	4	6
405TS	35	17 1/2	86	32	4	6
444T	42 1/4	18 1/2	92	33 1/2	5	8
444TS	38 1/2	18 1/2	92	33 1/2	5	8
445T	44 3/4	18 1/2	92	33 1/2	5	8
445TS	40 1/2	18 1/2	92	33 1/2	5	8
447T	51	20 1/2	98	33 1/2	5	8
449T	52 3/4	20 1/2	98	33 1/2	5	8

*7 1/4" for Falk Spacer on 444T frame and up

*7 3/4" for Woods Spacer on 404T frame and up

IMPORTANT: DO NOT USE FOR CONSTRUCTION UNLESS CERTIFIED.

DIMENSION DWG.
NO. R-3041

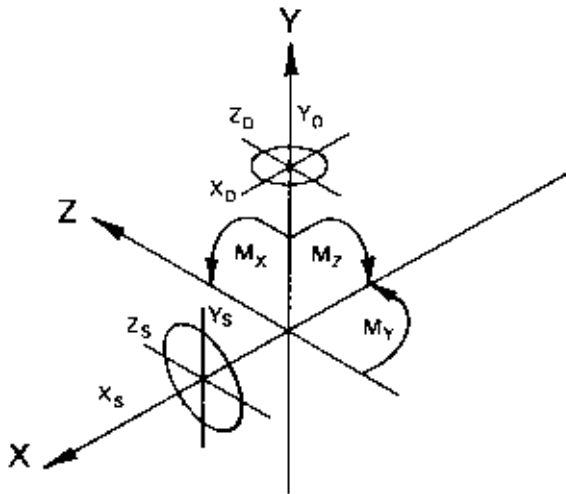

MAXIMUM FORCES ON FLANGES

FOR SUCTION FLANGE

$$\begin{aligned} \pm F_x &\leq 200 \text{ lbs./nom. in.} \leq 1.2W \\ \pm F_y &\leq 130 \text{ lbs./nom. in.} \leq 0.6W \\ \pm F_z &\leq 160 \text{ lbs./nom. in.} \leq 1.0W \\ F_r &= (F_y^2 + F_z^2)^{1/2} \leq 2000 \text{ lbs.} \end{aligned}$$

FOR DISCHARGE FLANGE

$$\begin{aligned} \pm F_x &\leq 1.3W \leq 160 \text{ lbs./nom. in.} \\ -F_y \text{ (Compression)} &\leq 200 \text{ lbs./nom. in.} \leq 1.2W \\ +F_y \text{ (Tension)} &\leq 100 \text{ lbs./nom. in.} \leq 0.5W \\ \pm F_z &\leq 1.0W \leq 130 \text{ lbs./nom. in.} \\ F_r &= (F_x^2 + F_z^2)^{1/2} \leq 2000 \text{ lbs.} \end{aligned}$$

WHERE

- F = Force in pounds
- F_r = Resultant force
- W = Weight of pump only, in pounds

**MAXIMUM MOMENTS APPLIED TO A PUMP ON A FULLY BOLTED AND GROUTED BASEPLATE.
LOADS ARE TO BE APPLIED ONLY THROUGH THE SUCTION AND DISCHARGE FLANGES.**

Pump Size	Type	Wt. - lbs. Pump only	± M _x lb. ft.	± M _y lb. ft.	± M _z lb. ft.
1 x 3 x 8 ¹ / ₂	R5140	210	690	340	725
1 ¹ / ₂ x 3 x 8 ¹ / ₂	R5140	235	690	340	725
2 x 3 x 8 ¹ / ₂	R5140	260	690	340	725
3 x 4 x 8 ¹ / ₂	R5140	285	725	295	600
4 x 6 x 8 ¹ / ₂	R5140	325	785	320	600
1 ¹ / ₂ x 3 x 10	R5140	255	760	310	600
2 x 3 x 10	R5140	290	760	310	600
3 x 4 x 10	R5140	320	830	340	600
4 x 6 x 10	R5140	360	950	340	600
1 x 2 x 11 ¹ / ₂	R5140	240	850	350	600
1 ¹ / ₂ x 3 x 11 ¹ / ₂	R5140	275	850	350	600
2 x 3 x 11 ¹ / ₂	R5140	315	870	355	600

Pump Size	Type	Wt. - lbs. Pump only	± M _x lb. ft.	± M _y lb. ft.	± M _z lb. ft.
3 x 4 x 11 ¹ / ₂	R5140	345	930	335	575
4 x 6 x 11 ¹ / ₂	R5140	430	980	350	760
1 ¹ / ₂ x 3 x 13 ¹ / ₂	R5140/R5170	400	1015	365	525
2 x 3 x 13 ¹ / ₂	R5140/R5170	414	1015	365	525
3 x 4 x 13 ¹ / ₂	R5140/R5170	430	1045	375	630
4 x 6 x 10	R5180	480	2300	1850	800
6 x 8 x 12 ¹ / ₂	R5180	560	2740	1490	800
2 x 4 x 15 ¹ / ₂	R5180	575	2530	1375	800
3 x 4 x 15 ¹ / ₂	R5180	587	2550	1385	800
4 x 6 x 15 ¹ / ₂	R5180	604	2740	1490	800
6 x 8 x 15 ¹ / ₂	R5240	919	3000	1615	1500
8 x 10 x 15 ¹ / ₂	R5240	942	3340	1810	1500

Maximum allowable forces and moments calculated from these force equations or the tabulated moment tables are those resulting in a maximum of .010 inch movement of the shaft measured at the shaft coupling when the pump is mounted on its baseplate and that baseplate is fully bolted to a properly designed foundation and is fully grouted in place. For a full discussion see API Standard 610, 5th Edition.

PUMP PERFORMANCE: This curve, based on extensive tests, defines the average performance of this pump for liquids having a viscosity of 70 SSU or less. Actual performance of individual units may differ slightly from the performance indicated on this curve. Pump applications made from the data contained herein are subject to confirmation and acceptance by our Engineering Department at our Indianapolis Office.

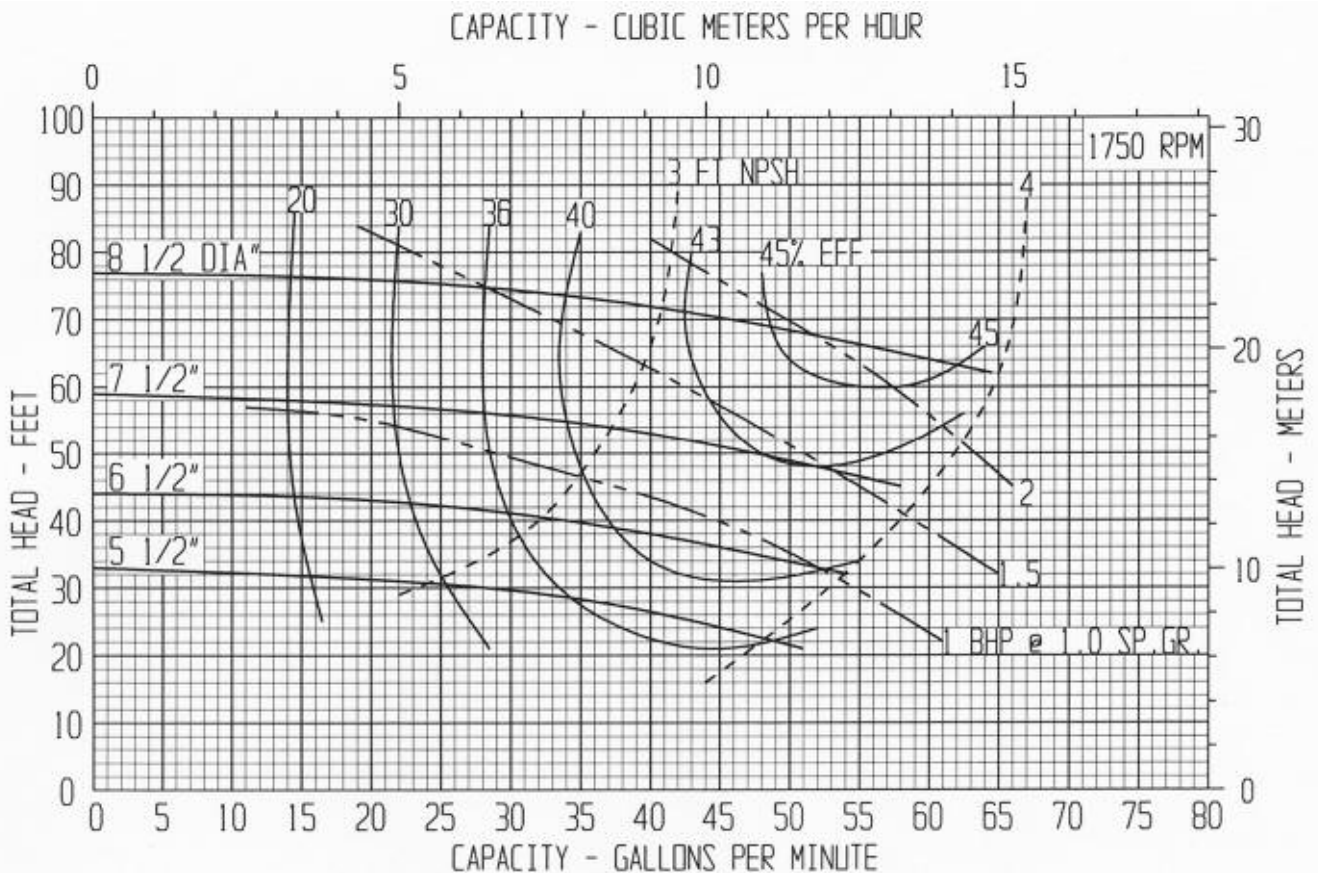
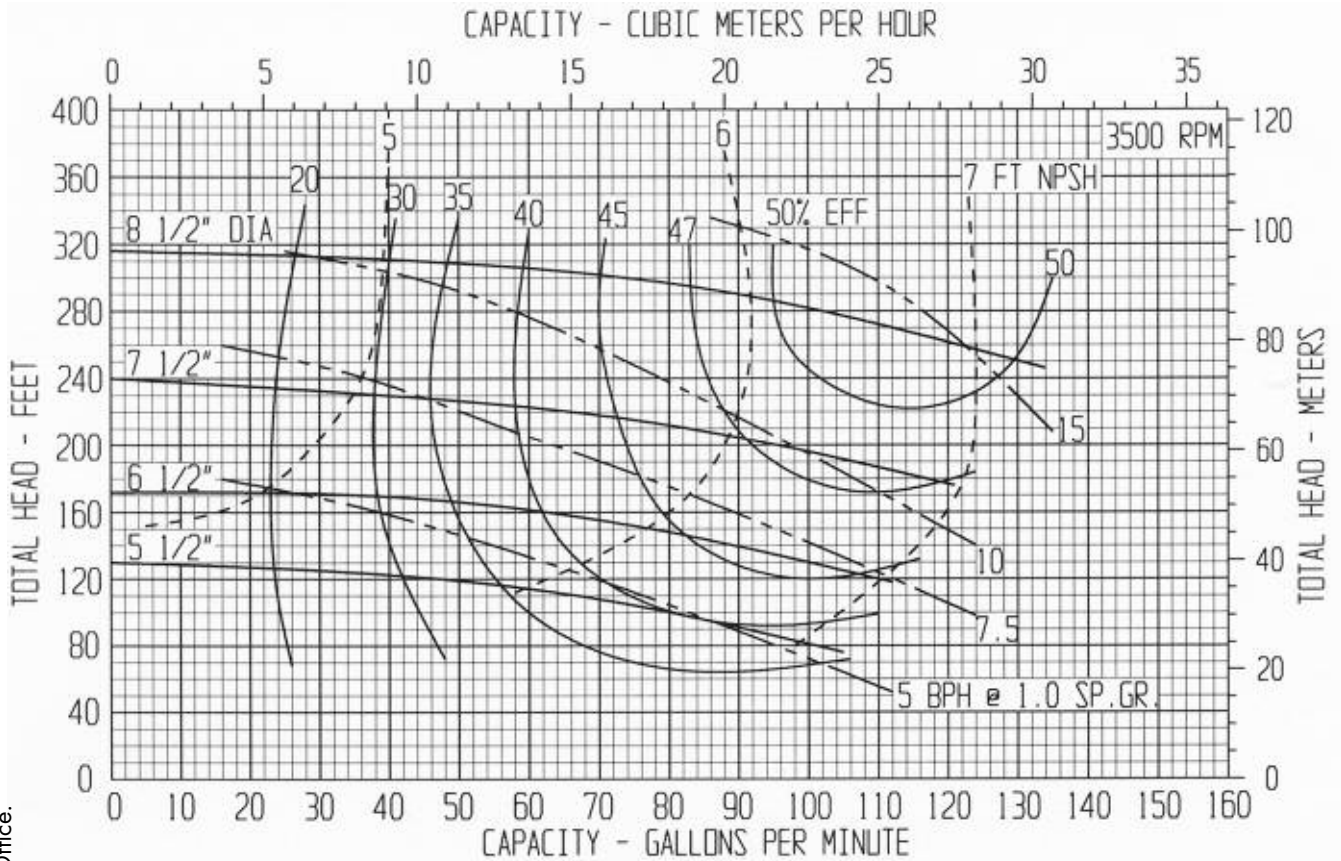

PUMP PERFORMANCE: This curve, based on extensive tests, defines the average performance of this pump for liquids having a viscosity of 70 SSU or less. Actual performance of individual units may differ slightly from the performance indicated on this curve. Pump applications made from the data contained herein are subject to confirmation and acceptance by our Engineering Department at our Indianapolis Office.

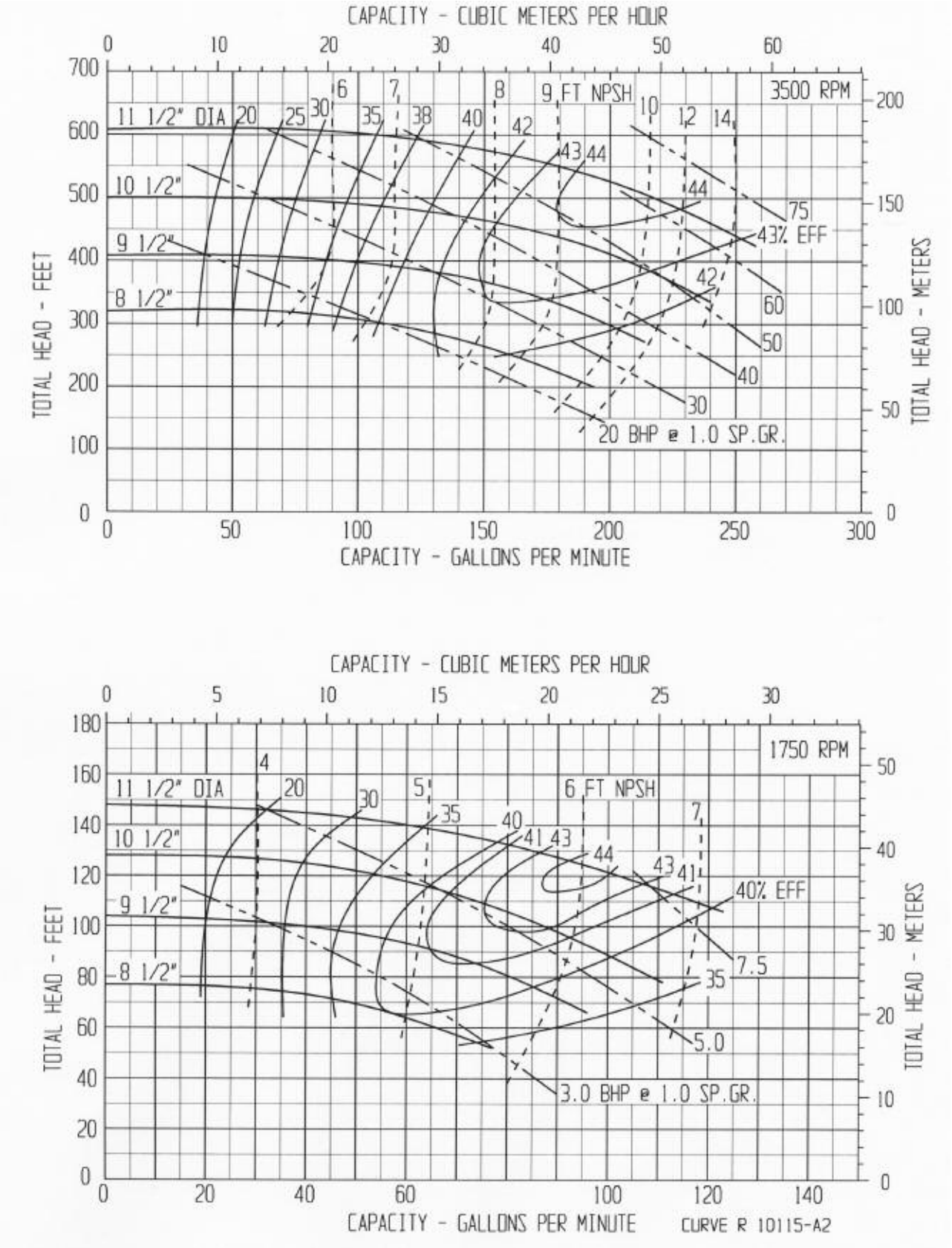

PUMP PERFORMANCE: This curve, based on extensive tests, defines the average performance of this pump for liquids having a viscosity of 70 SSU or less. Actual performance of individual units may differ slightly from the performance indicated on this curve. Pump applications made from the data contained herein are subject to confirmation and acceptance by our Engineering Department at our Indianapolis Office.

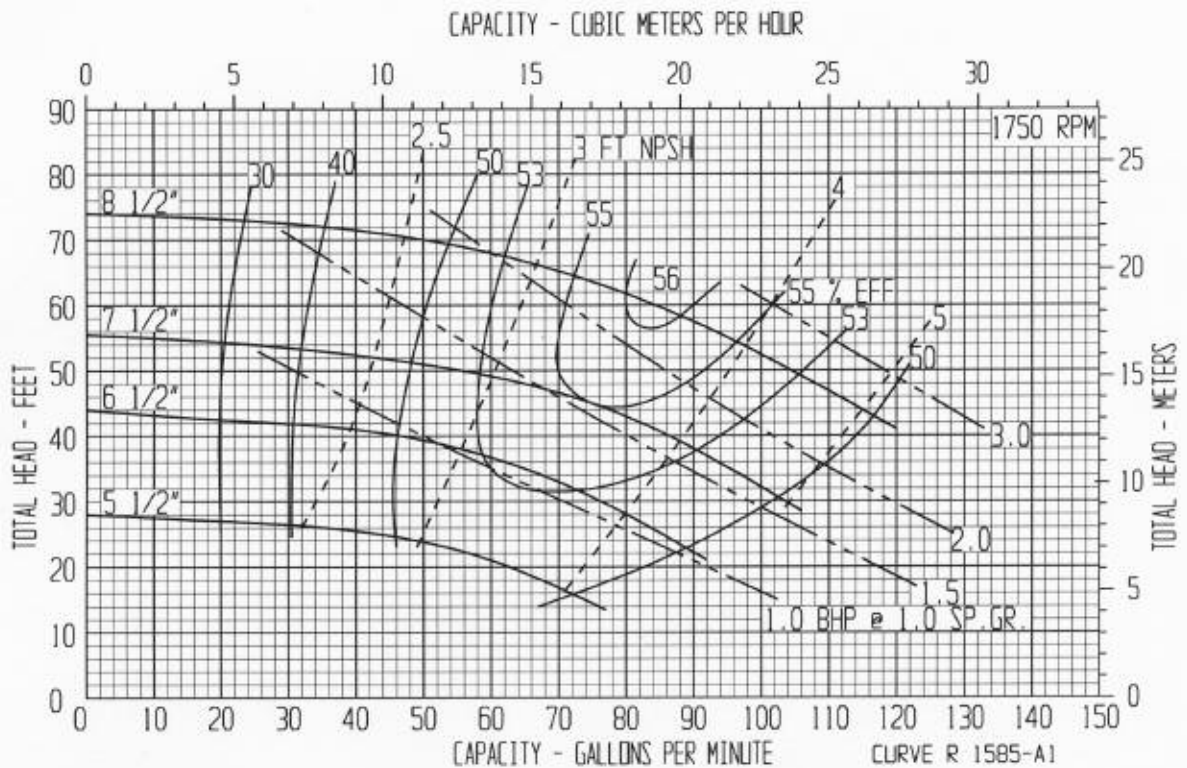
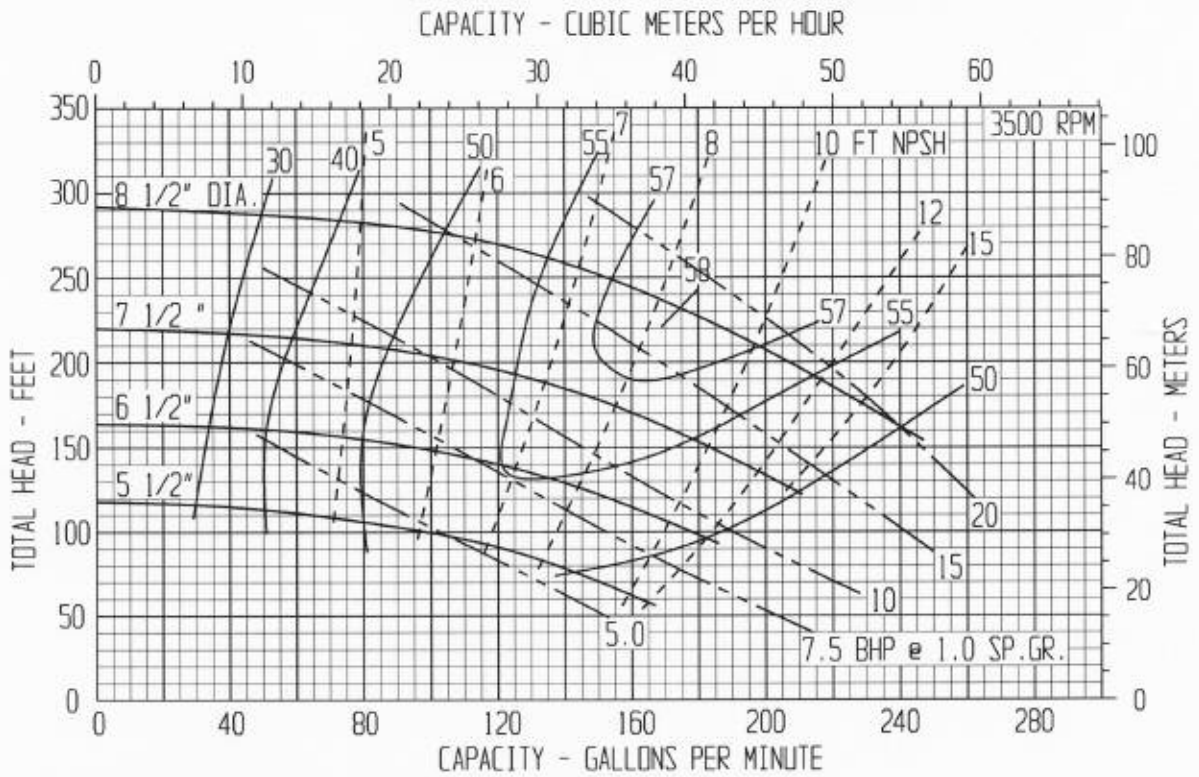

PUMP PERFORMANCE: This curve, based on extensive tests, defines the average performance of this pump for liquids having a viscosity of 70 SSU or less. Actual performance of individual units may differ slightly from the performance indicated on this curve. Pump applications made from the data contained herein are subject to confirmation and acceptance by our Engineering Department at our Indianapolis Office.

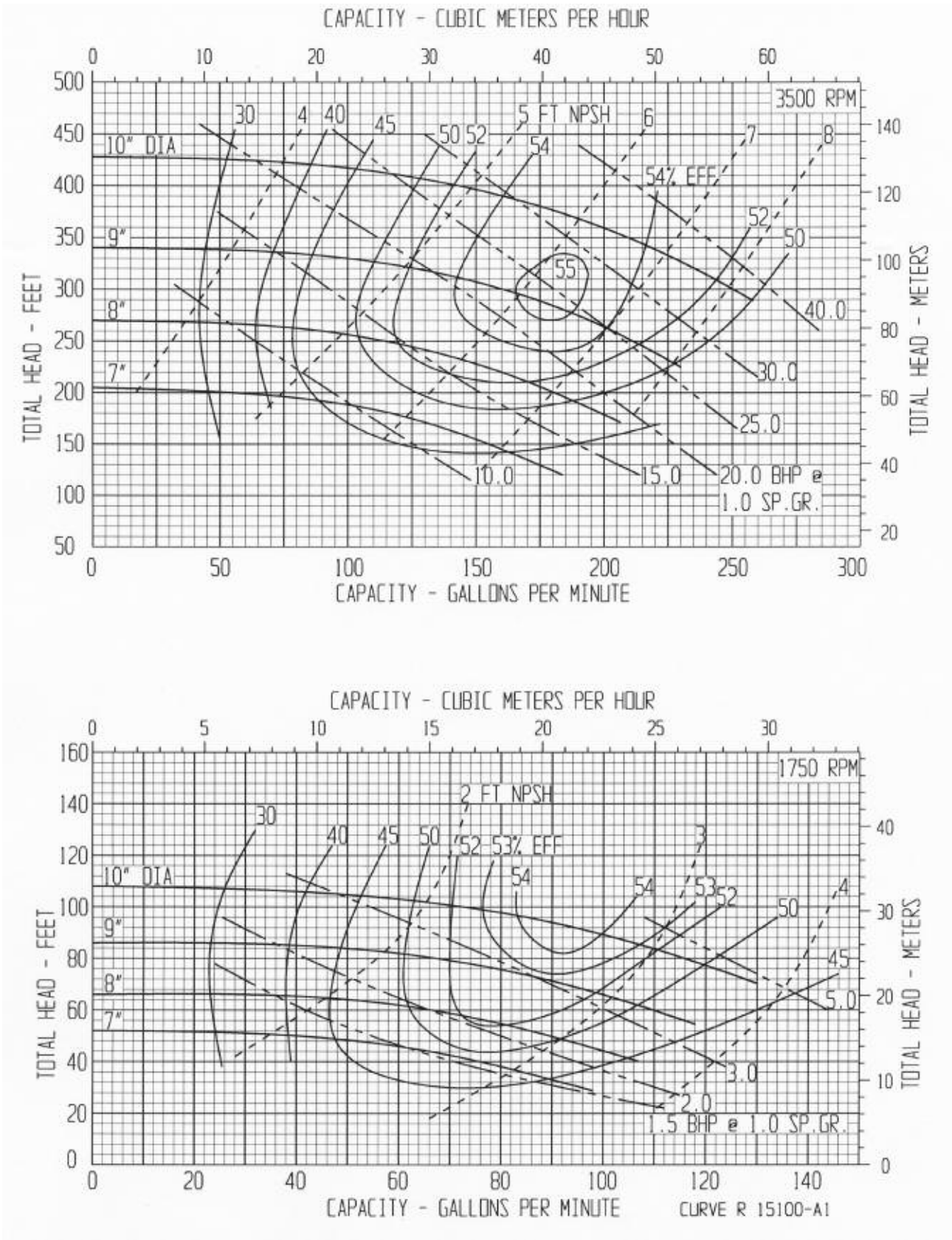

PUMP PERFORMANCE: This curve, based on extensive tests, defines the average performance of this pump for liquids having a viscosity of 70 SSU or less. Actual performance of individual units may differ slightly from the performance indicated on this curve. Pump applications made from the data contained herein are subject to confirmation and acceptance by our Engineering Department at our Indianapolis Office.

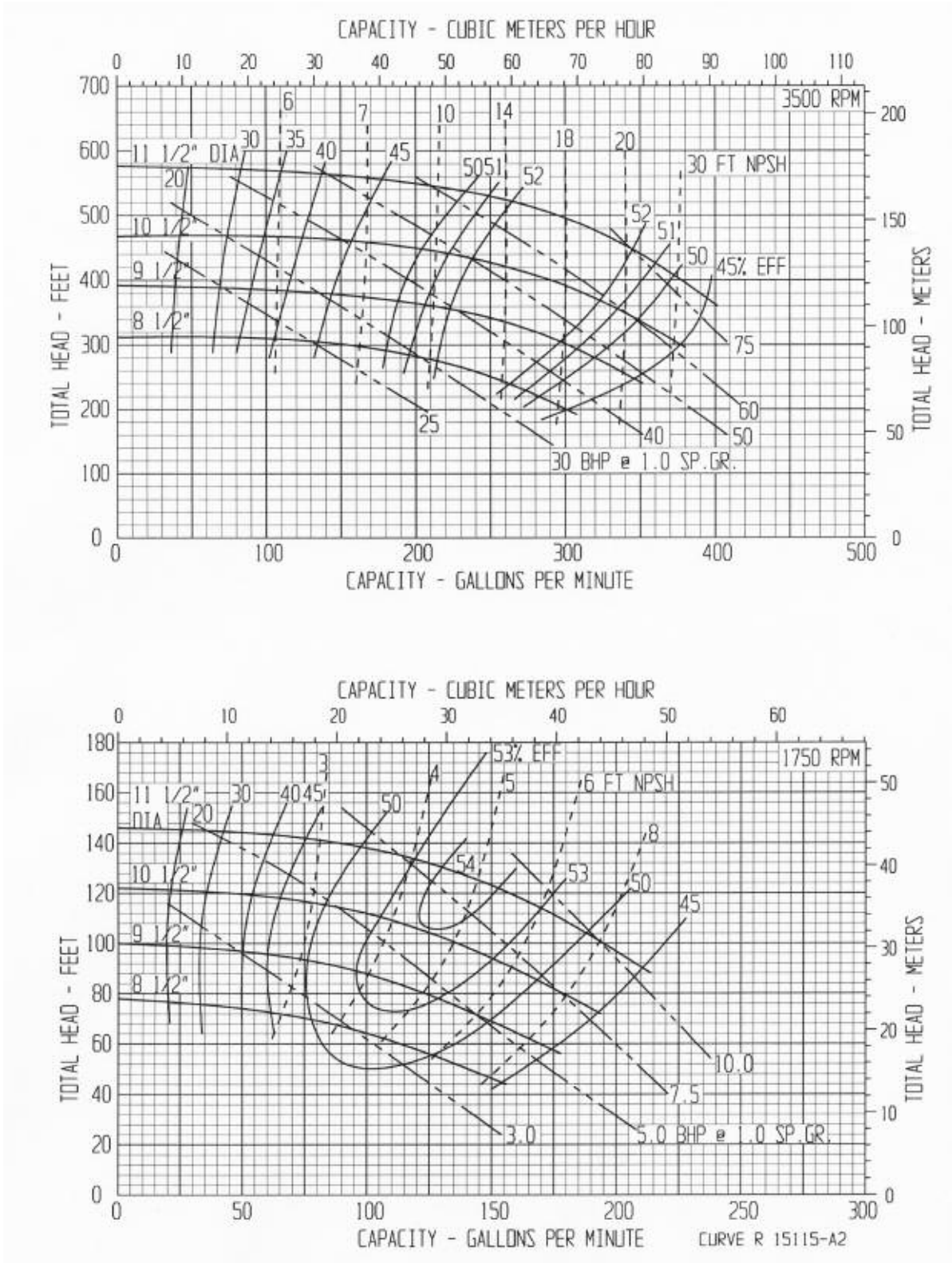

PUMP PERFORMANCE: This curve, based on extensive tests, defines the average performance of this pump for liquids having a viscosity of 70 SSU or less. Actual performance of individual units may differ slightly from the performance indicated on this curve. Pump applications made from the data contained herein are subject to confirmation and acceptance by our Engineering Department at our Indianapolis Office.

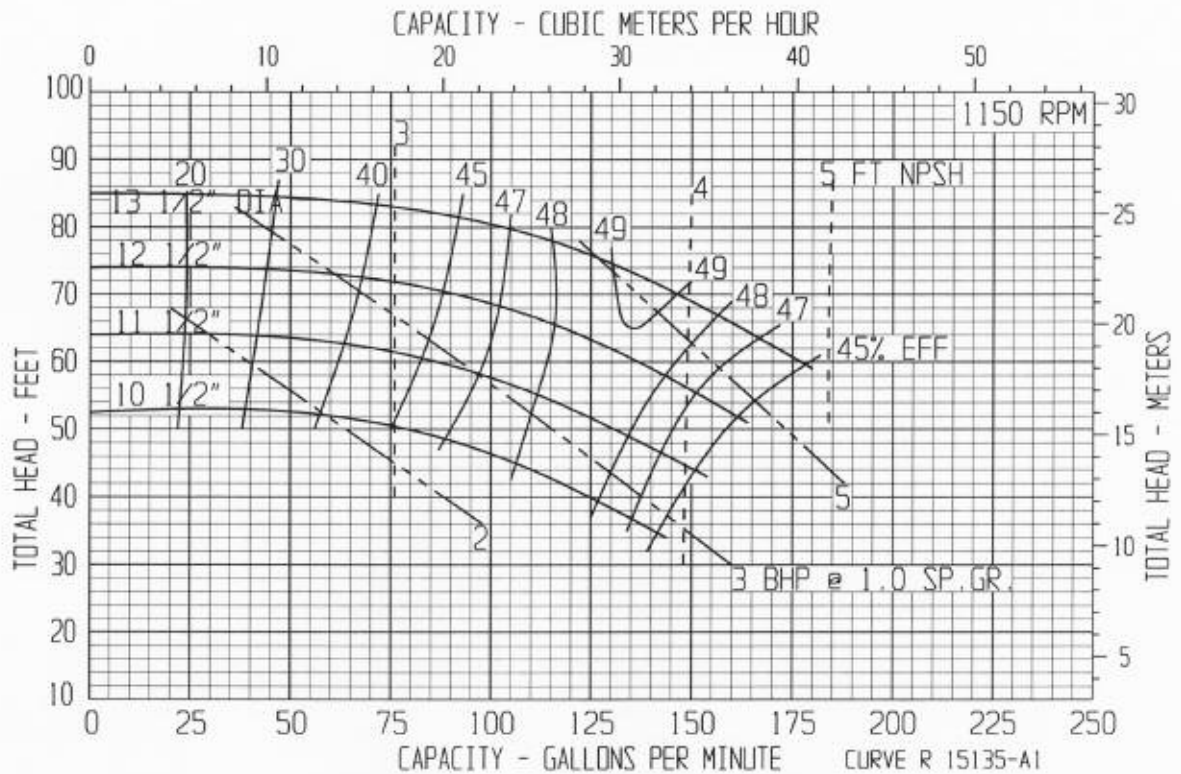
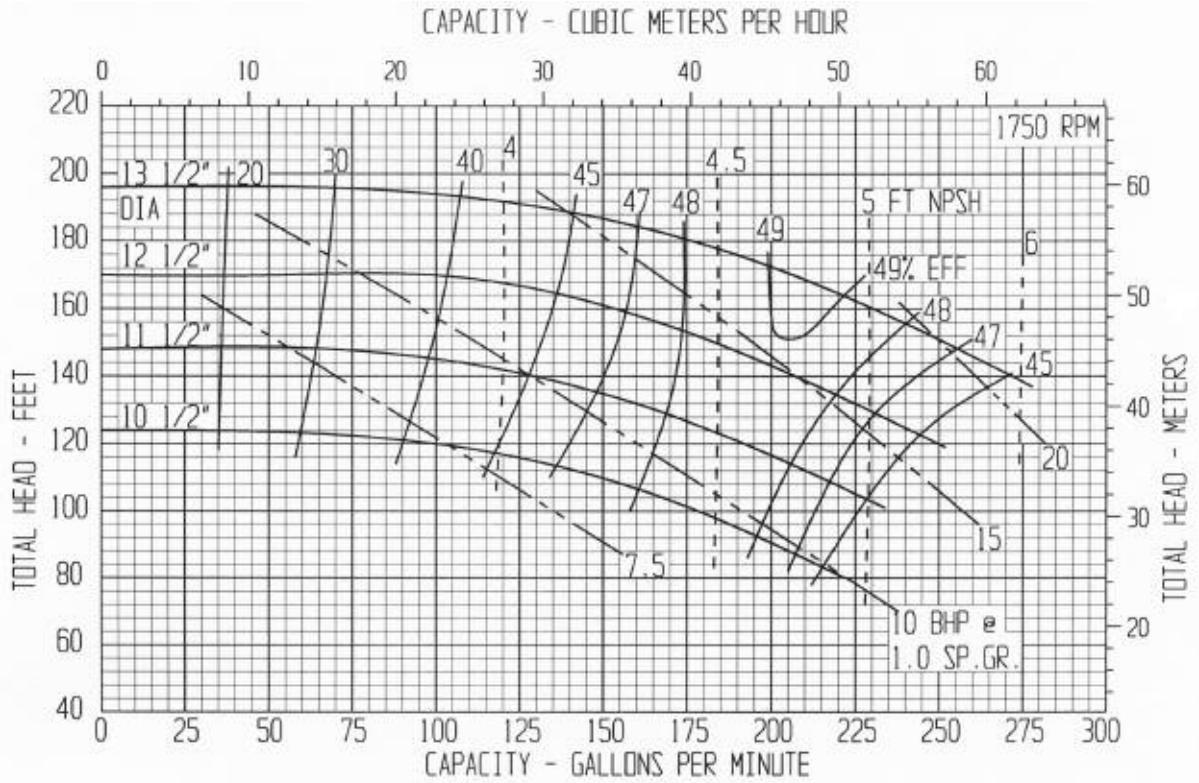

PUMP PERFORMANCE: This curve, based on extensive tests, defines the average performance of this pump for liquids having a viscosity of 70 SSU or less. Actual performance of individual units may differ slightly from the performance indicated on this curve. Pump applications made from the data contained herein are subject to confirmation and acceptance by our Engineering Department at our Indianapolis Office.

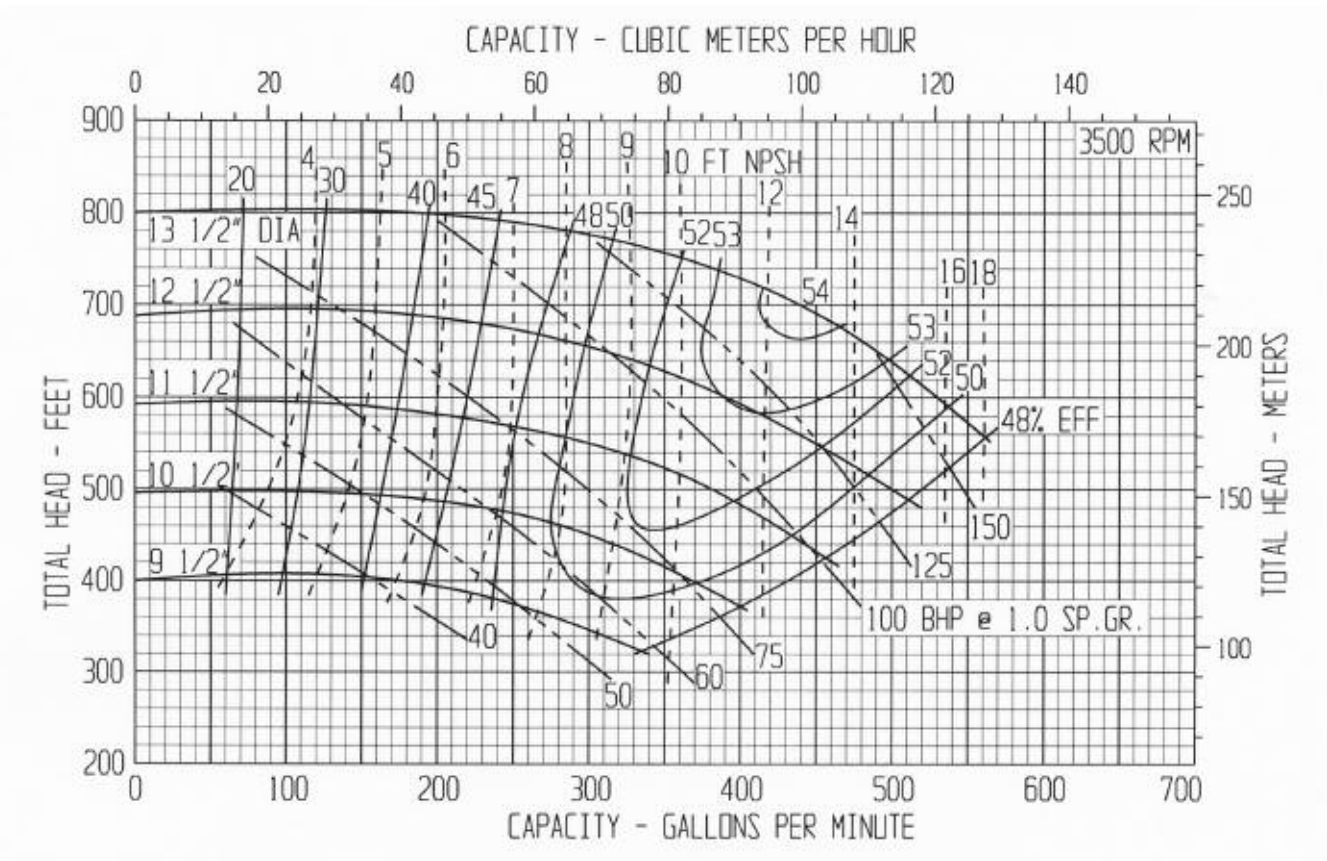

PUMP PERFORMANCE: This curve, based on extensive tests, defines the average performance of this pump for liquids having a viscosity of 70 SSU or less. Actual performance of individual units may differ slightly from the performance indicated on this curve. Pump applications made from the data contained herein are subject to confirmation and acceptance by our Engineering Department at our Indianapolis Office.

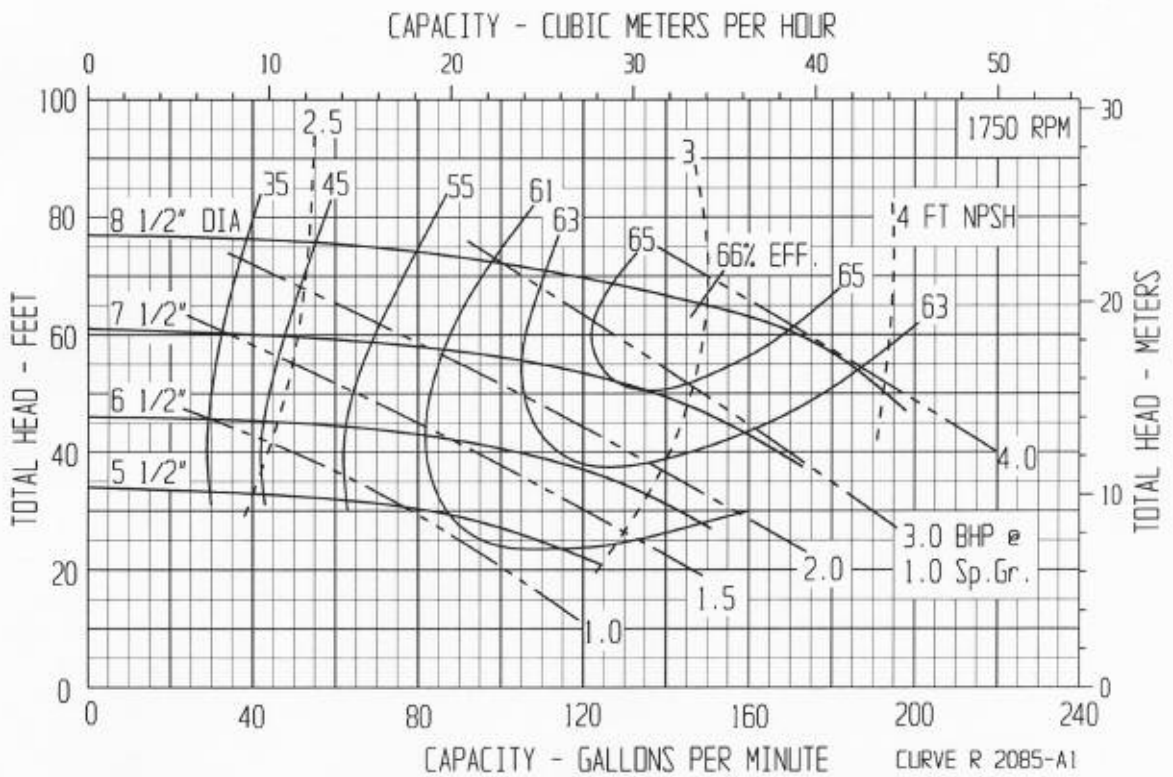
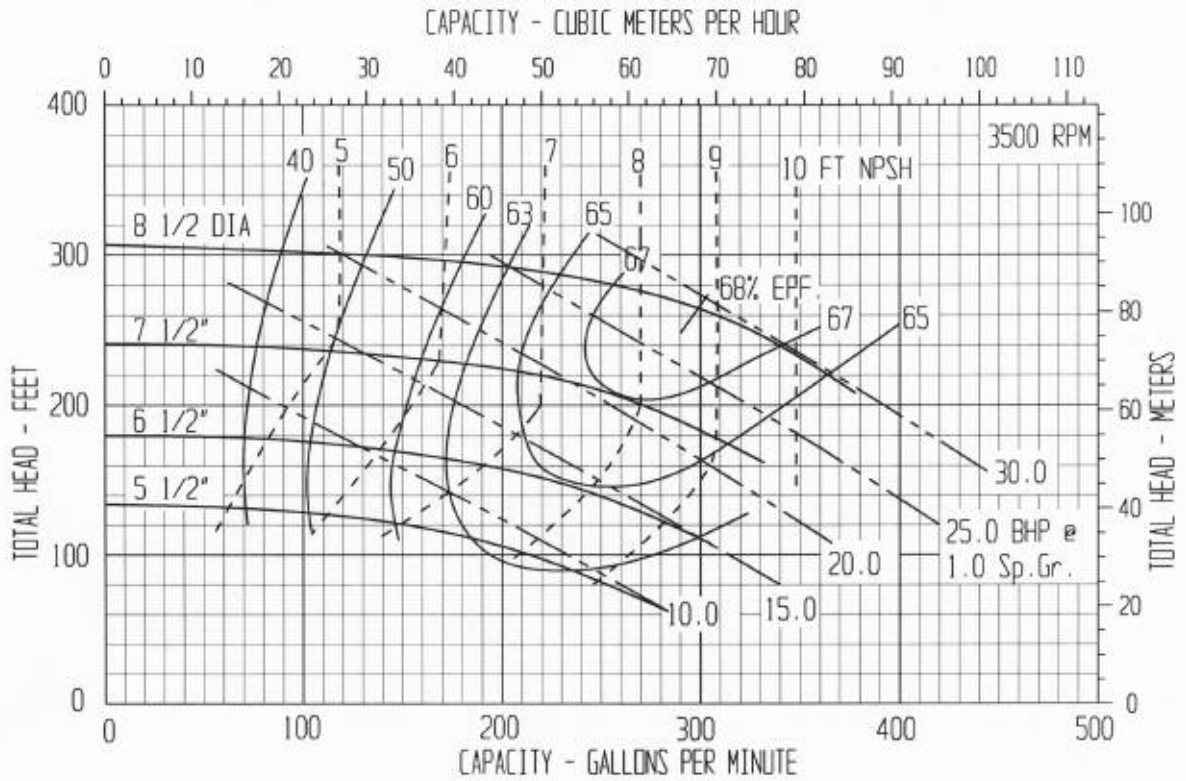

PUMP PERFORMANCE: This curve, based on extensive tests, defines the average performance of this pump for liquids having a viscosity of 70 SSU or less. Actual performance of individual units may differ slightly from the performance indicated on this curve. Pump applications made from the data contained herein are subject to confirmation and acceptance by our Engineering Department at our Indianapolis Office.

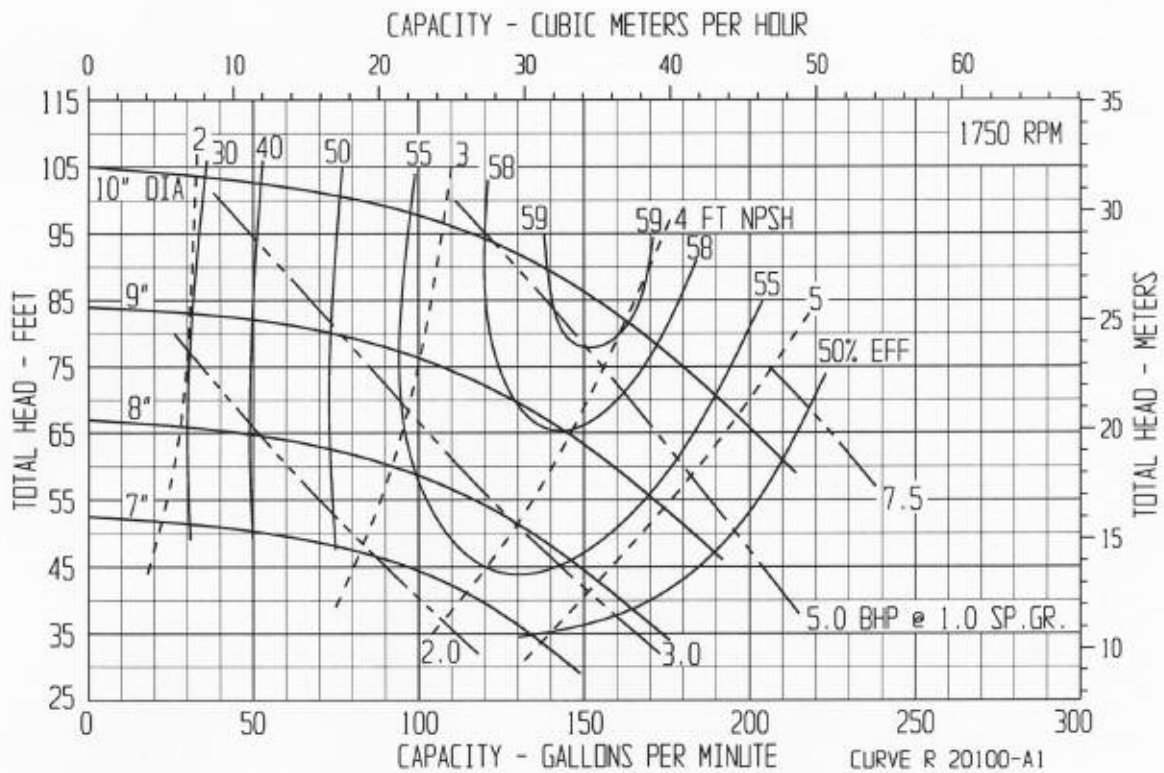
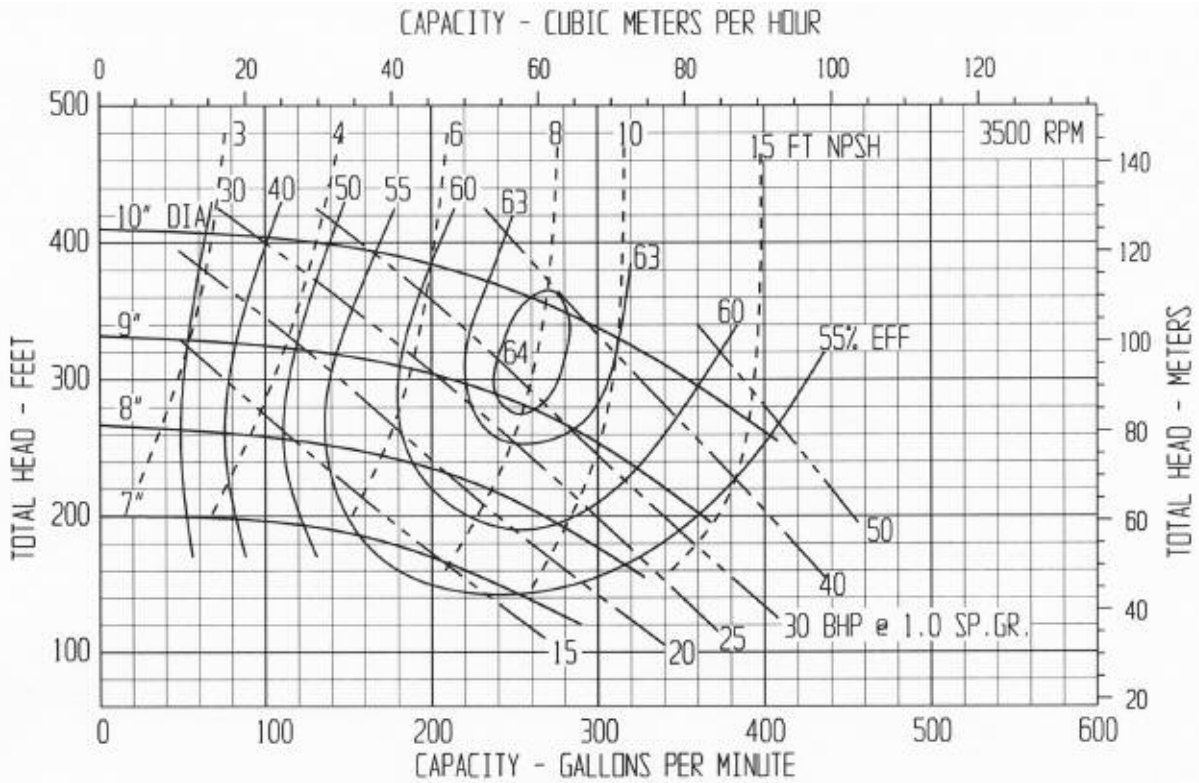

PUMP PERFORMANCE: This curve, based on extensive tests, defines the average performance of this pump for liquids having a viscosity of 70 SSU or less. Actual performance of individual units may differ slightly from the performance indicated on this curve. Pump applications made from the data contained herein are subject to confirmation and acceptance by our Engineering Department at our Indianapolis Office.

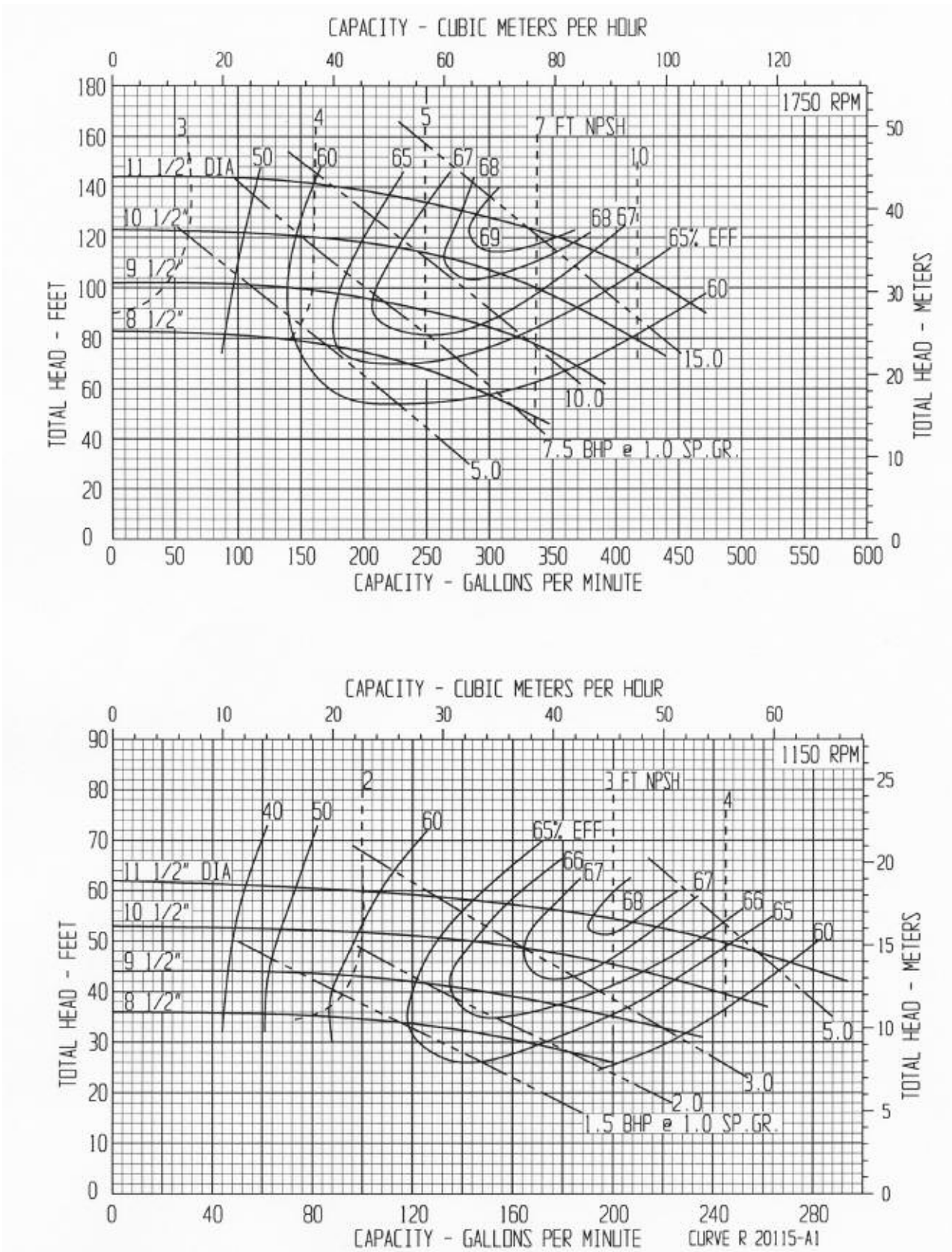

PUMP PERFORMANCE: This curve, based on extensive tests, defines the average performance of this pump for liquids having a viscosity of 70 SSU or less. Actual performance of individual units may differ slightly from the performance indicated on this curve. Pump applications made from the data contained herein are subject to confirmation and acceptance by our Engineering Department at our Indianapolis Office.

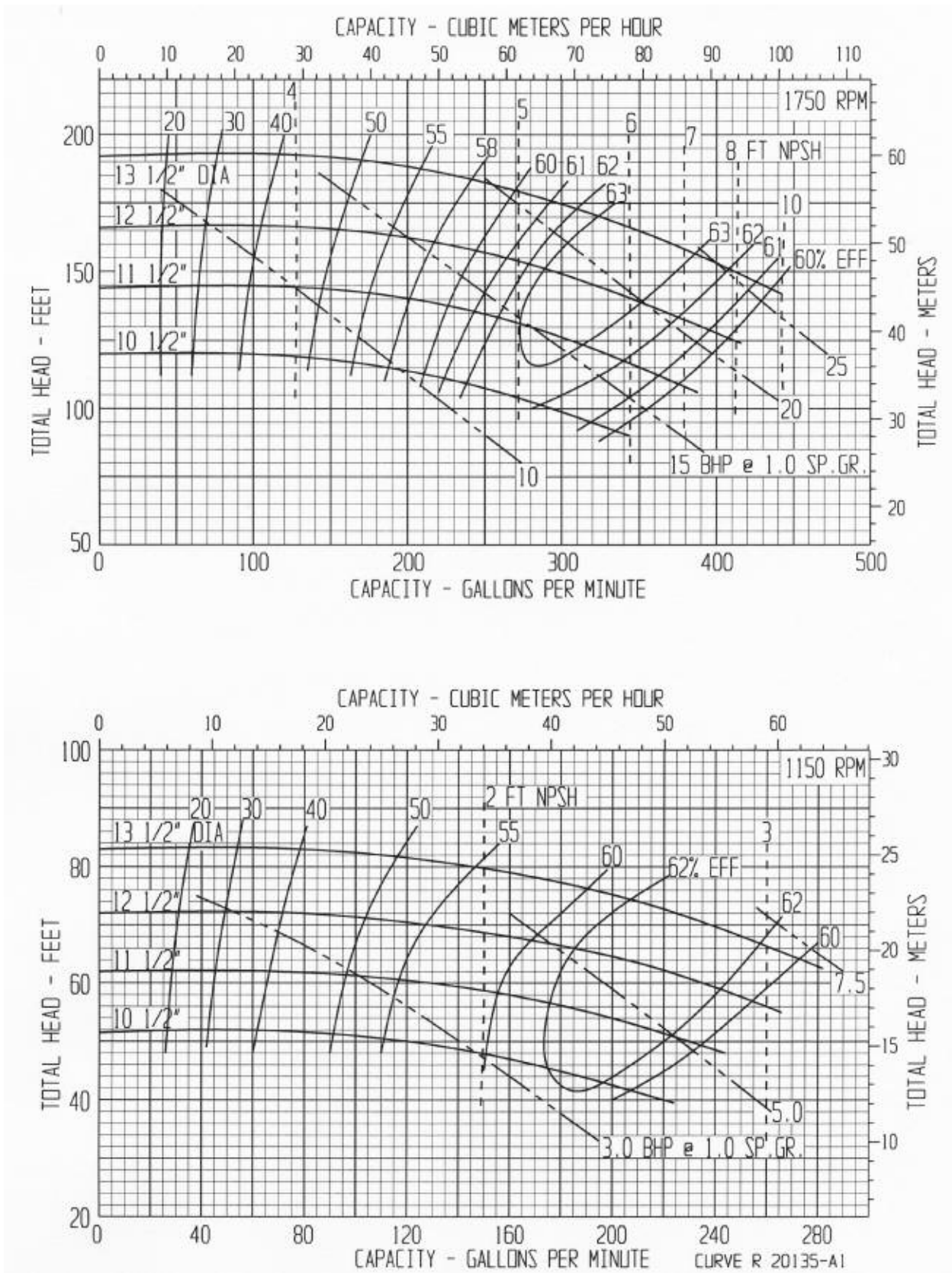

PUMP PERFORMANCE: This curve, based on extensive tests, defines the average performance of this pump for liquids having a viscosity of 70 SSU or less. Actual performance of individual units may differ slightly from the performance indicated on this curve. Pump applications made from the data contained herein are subject to confirmation and acceptance by our Engineering Department at our Indianapolis Office.

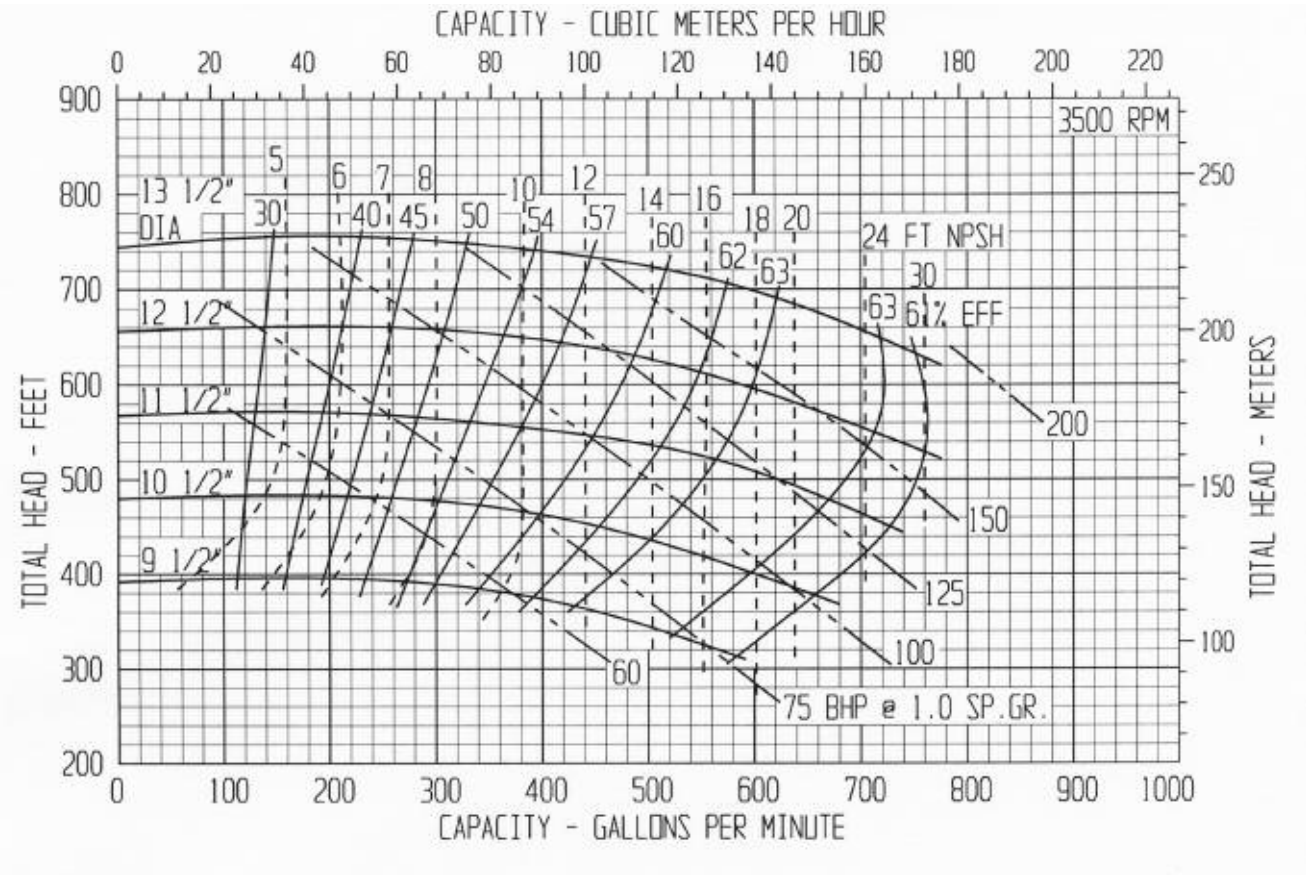

PUMP PERFORMANCE: This curve, based on extensive tests, defines the average performance of this pump for liquids having a viscosity of 70 SSU or less. Actual performance of individual units may differ slightly from the performance indicated on this curve. Pump applications made from the data contained herein are subject to confirmation and acceptance by our Engineering Department at our Indianapolis Office.

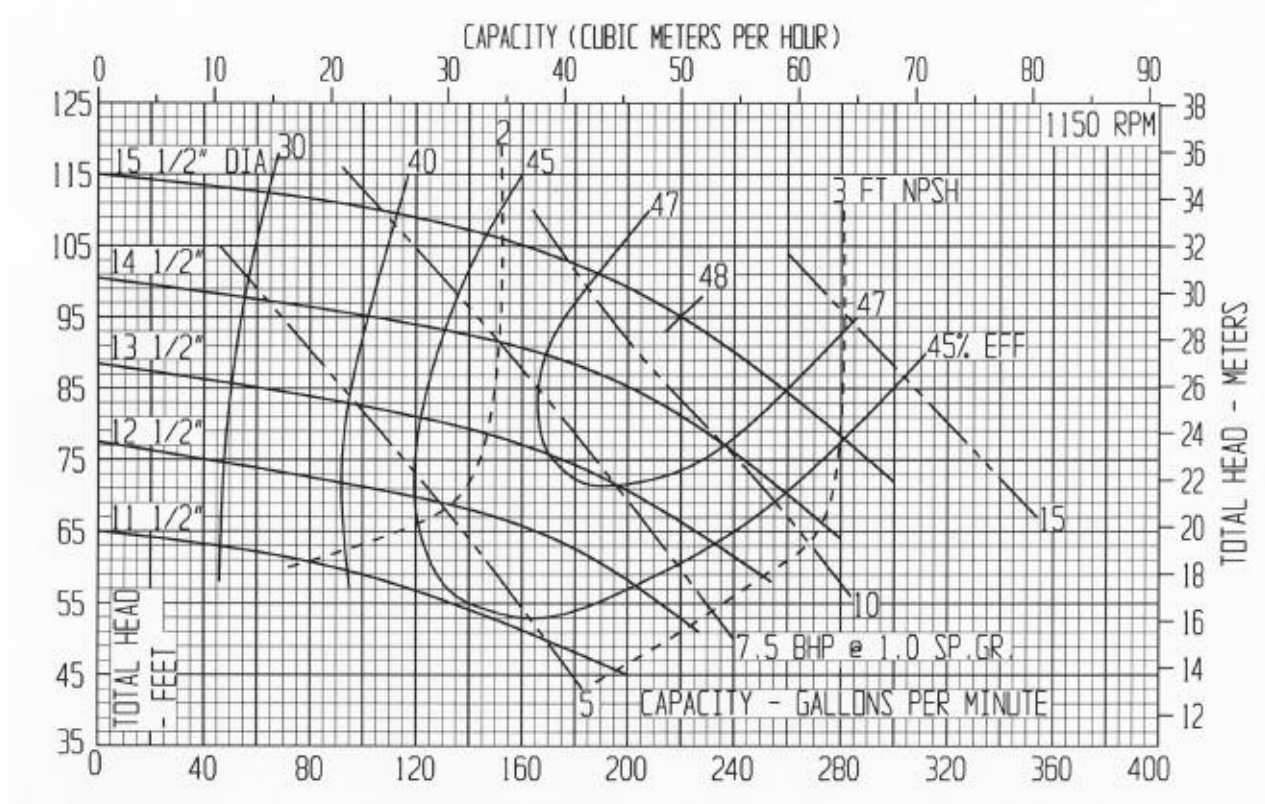
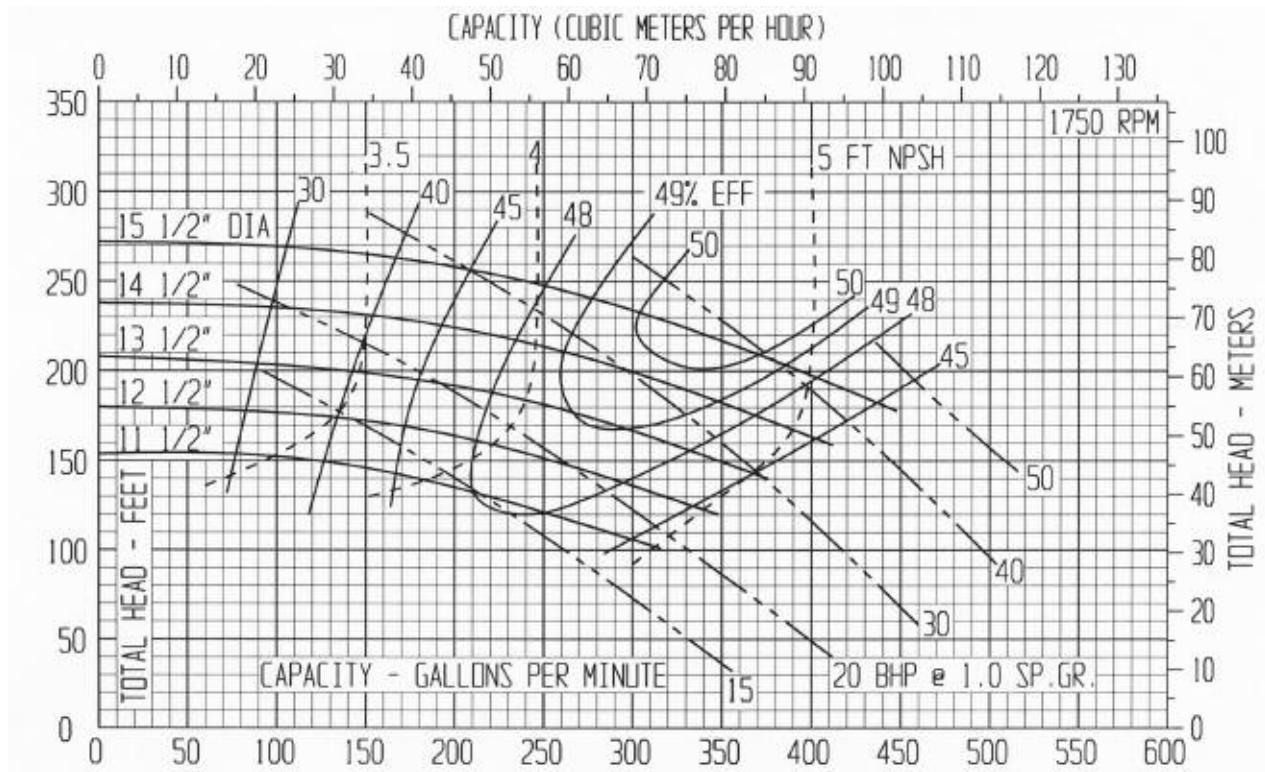

PUMP PERFORMANCE: This curve, based on extensive tests, defines the average performance of this pump for liquids having a viscosity of 70 SSU or less. Actual performance of individual units may differ slightly from the performance indicated on this curve. Pump applications made from the data contained herein are subject to confirmation and acceptance by our Engineering Department at our Indianapolis Office.

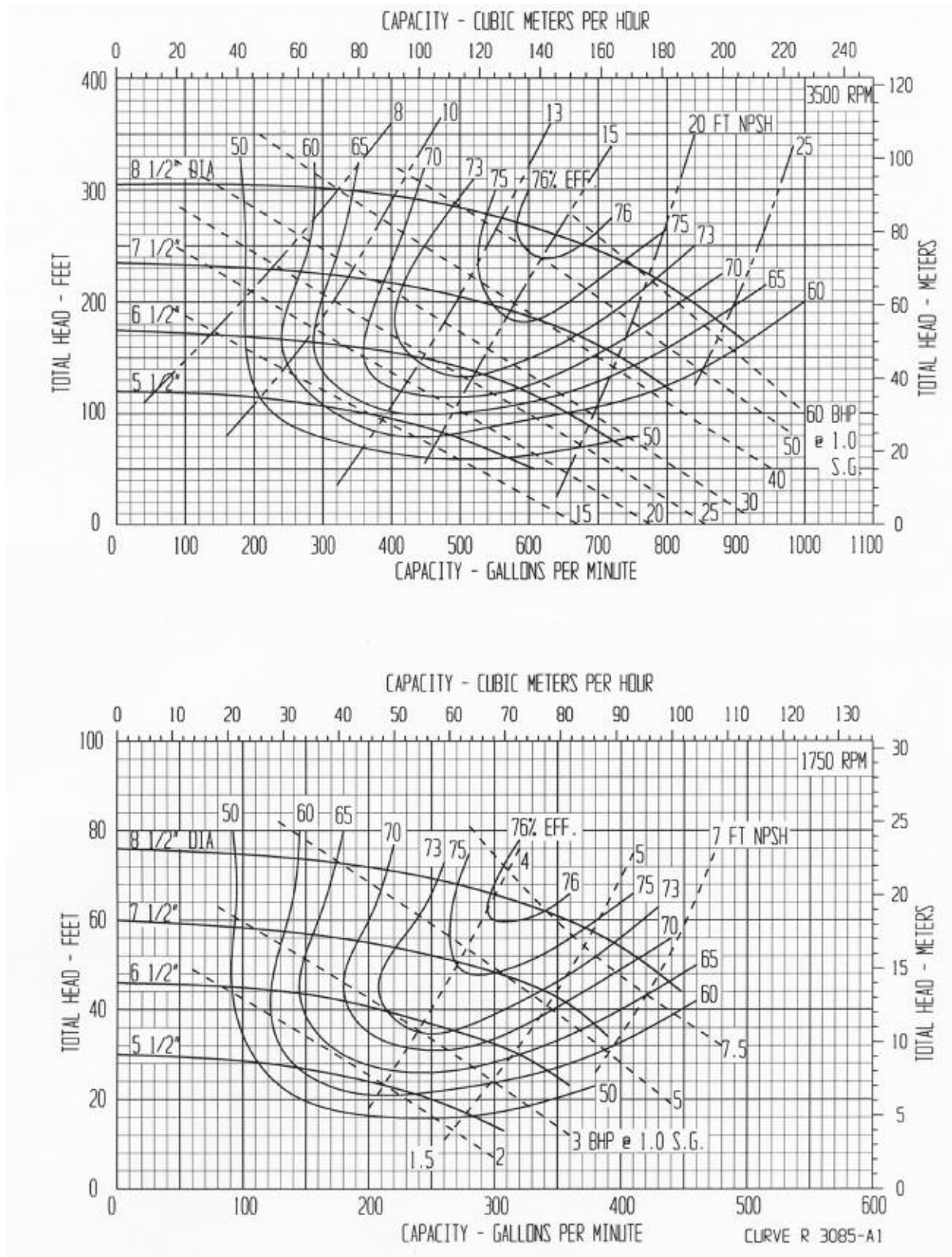

PUMP PERFORMANCE: This curve, based on extensive tests, defines the average performance of this pump for liquids having a viscosity of 70 SSU or less. Actual performance of individual units may differ slightly from the performance indicated on this curve. Pump applications made from the data contained herein are subject to confirmation and acceptance by our Engineering Department at our Indianapolis Office.

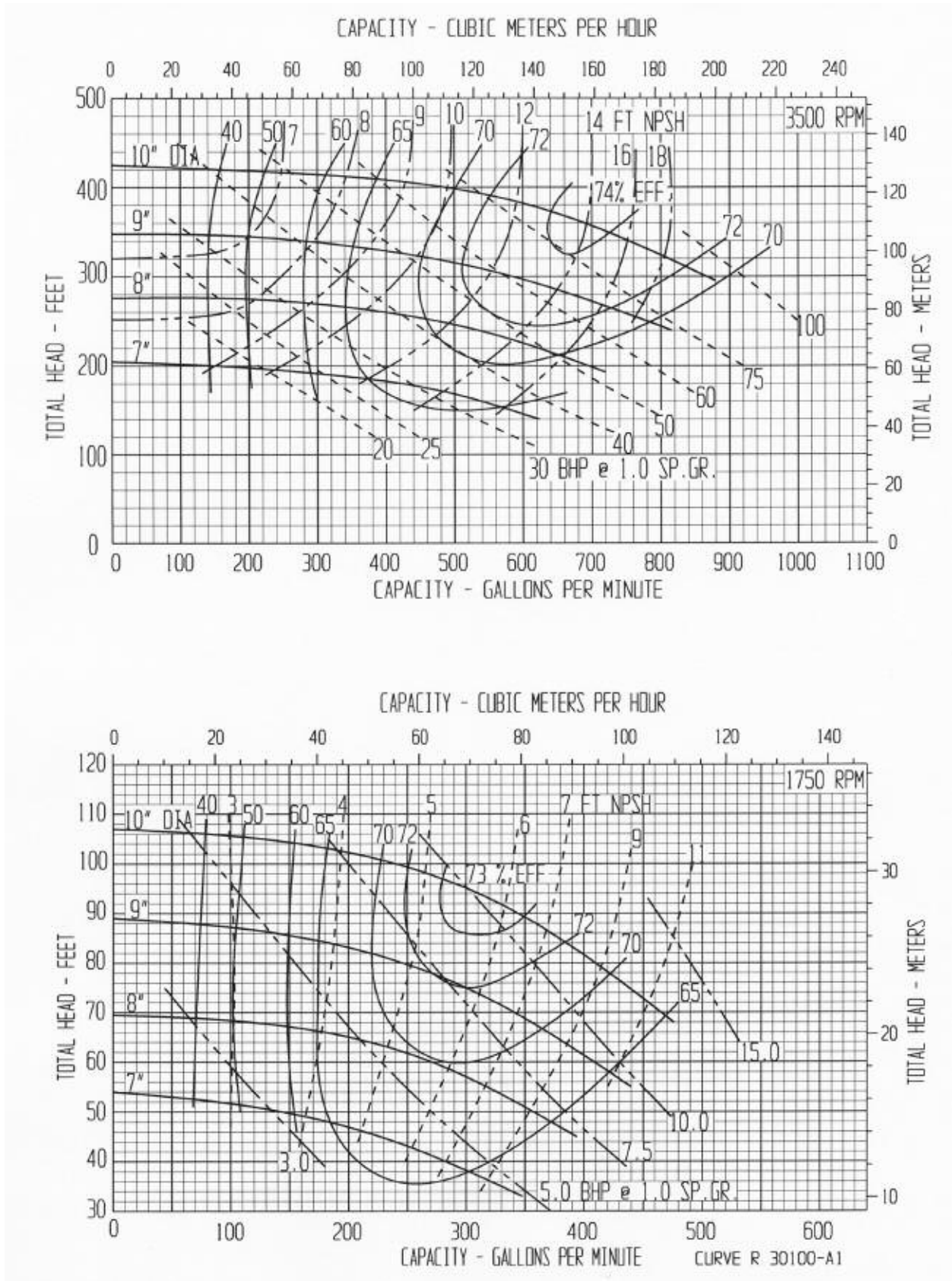

PUMP PERFORMANCE: This curve, based on extensive tests, defines the average performance of this pump for liquids having a viscosity of 70 SSU or less. Actual performance of individual units may differ slightly from the performance indicated on this curve. Pump applications made from the data contained herein are subject to confirmation and acceptance by our Engineering Department at our Indianapolis Office.

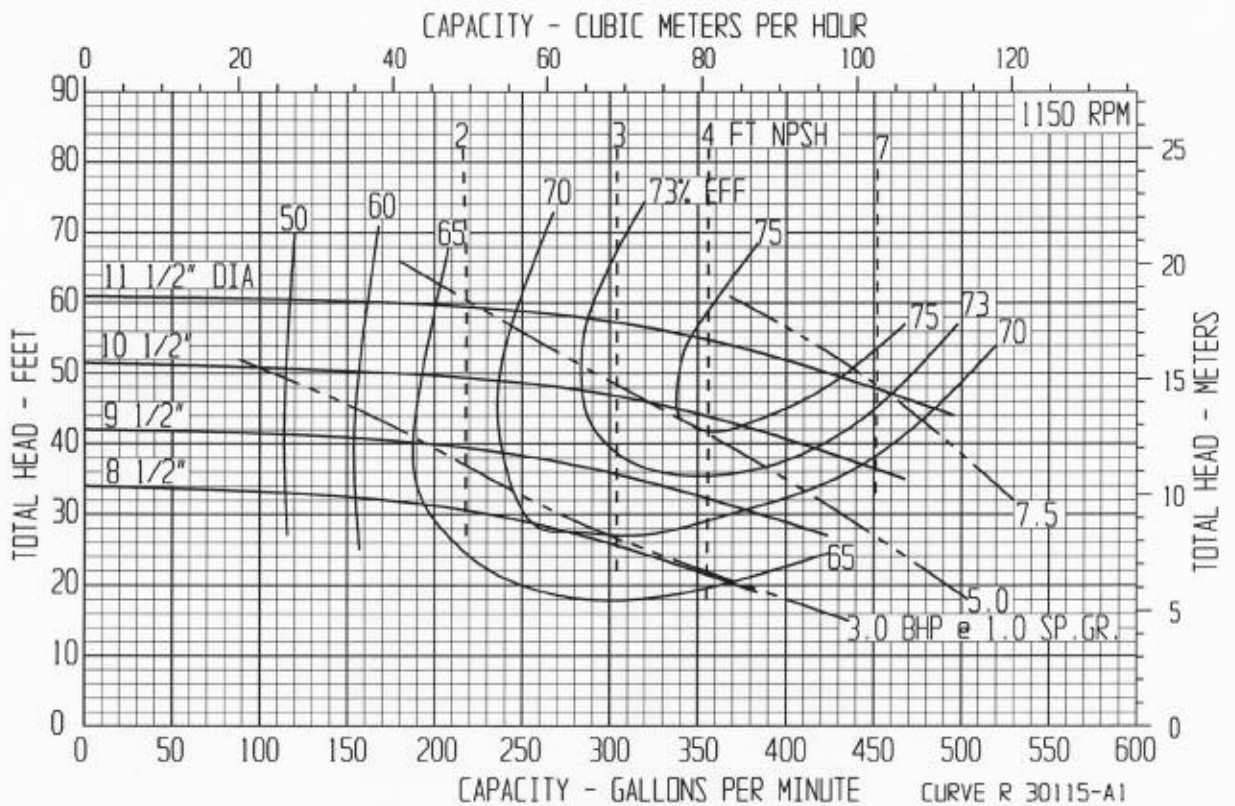
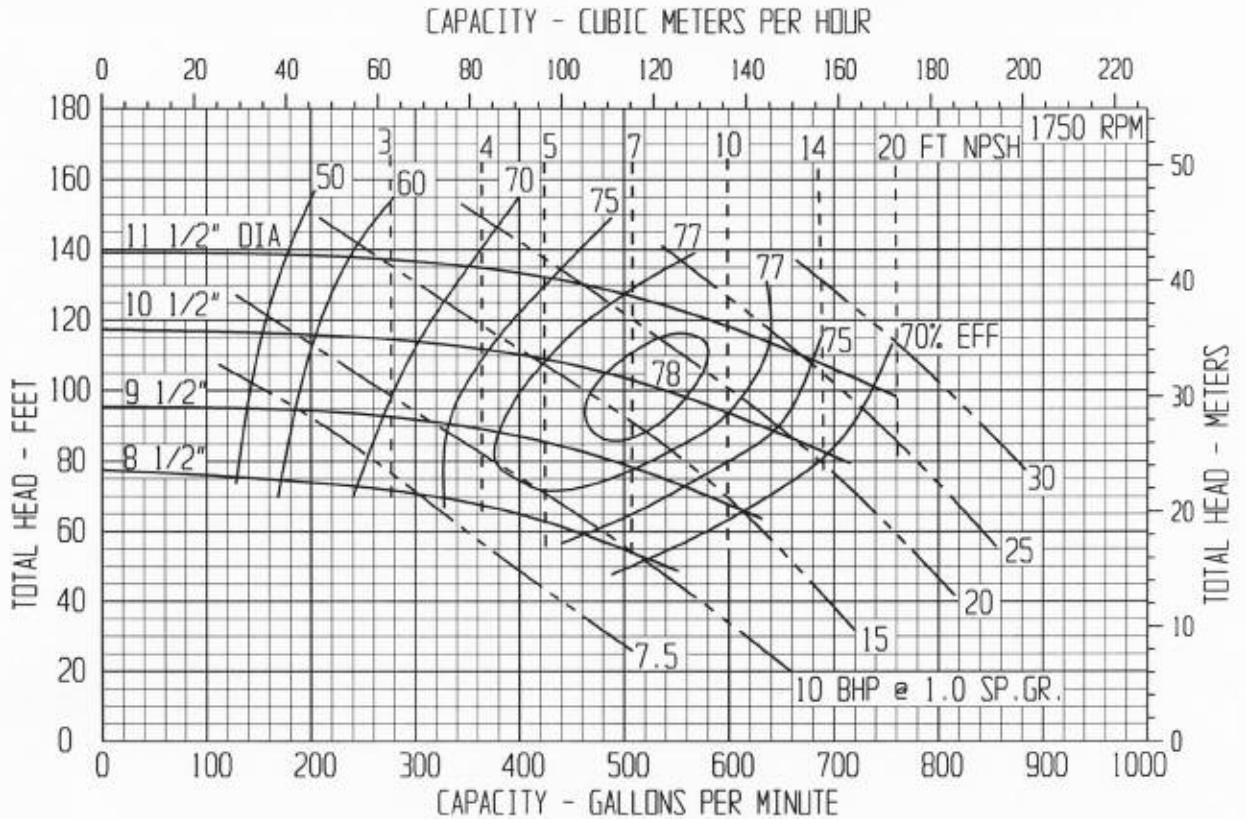

PUMP PERFORMANCE: This curve, based on extensive tests, defines the average performance of this pump for liquids having a viscosity of 70 SSU or less. Actual performance of individual units may differ slightly from the performance indicated on this curve. Pump applications made from the data contained herein are subject to confirmation and acceptance by our Engineering Department at our Indianapolis Office.

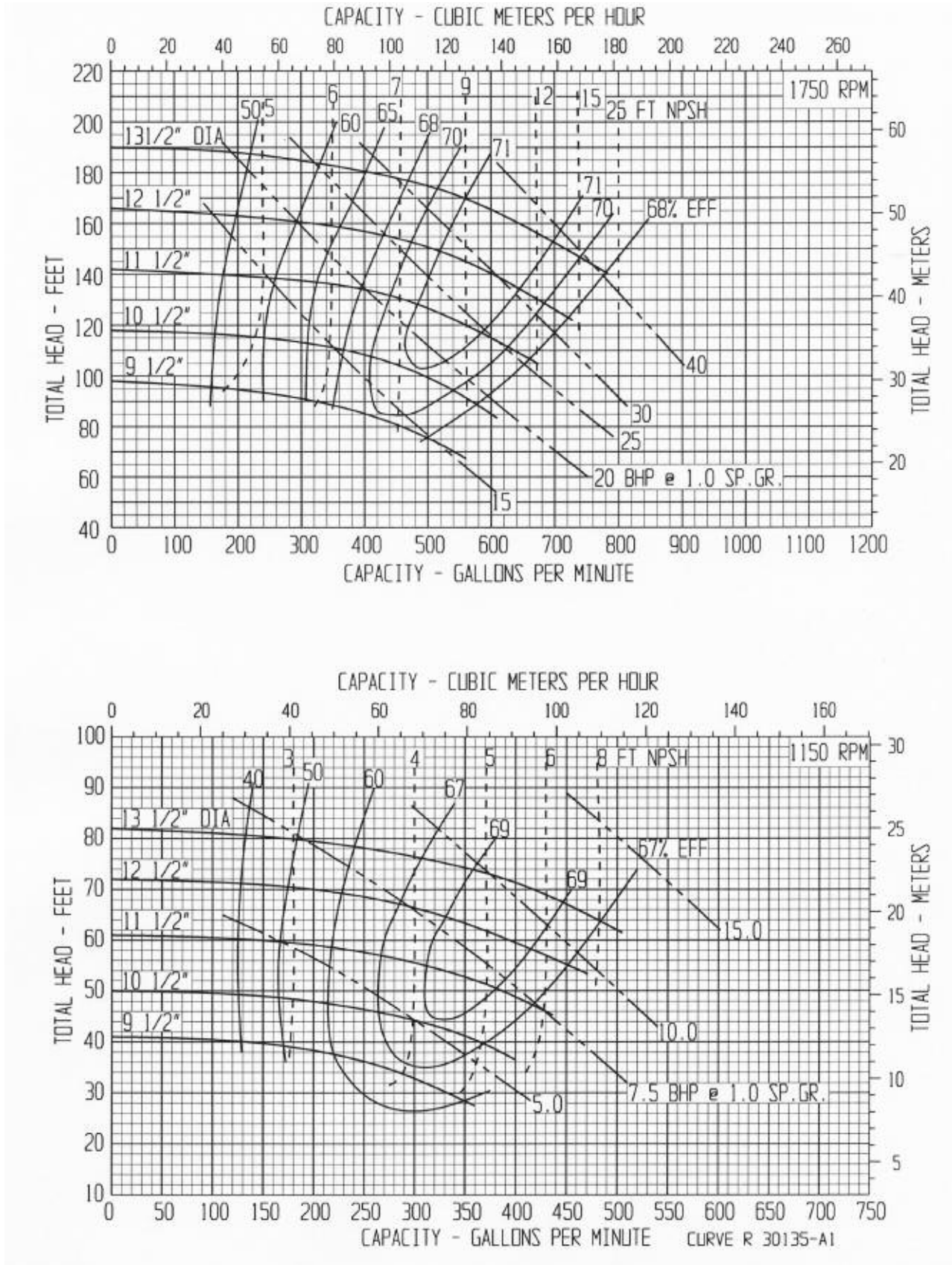

PUMP PERFORMANCE: This curve, based on extensive tests, defines the average performance of this pump for liquids having a viscosity of 70 SSU or less. Actual performance of individual units may differ slightly from the performance indicated on this curve. Pump applications made from the data contained herein are subject to confirmation and acceptance by our Engineering Department at our Indianapolis Office.

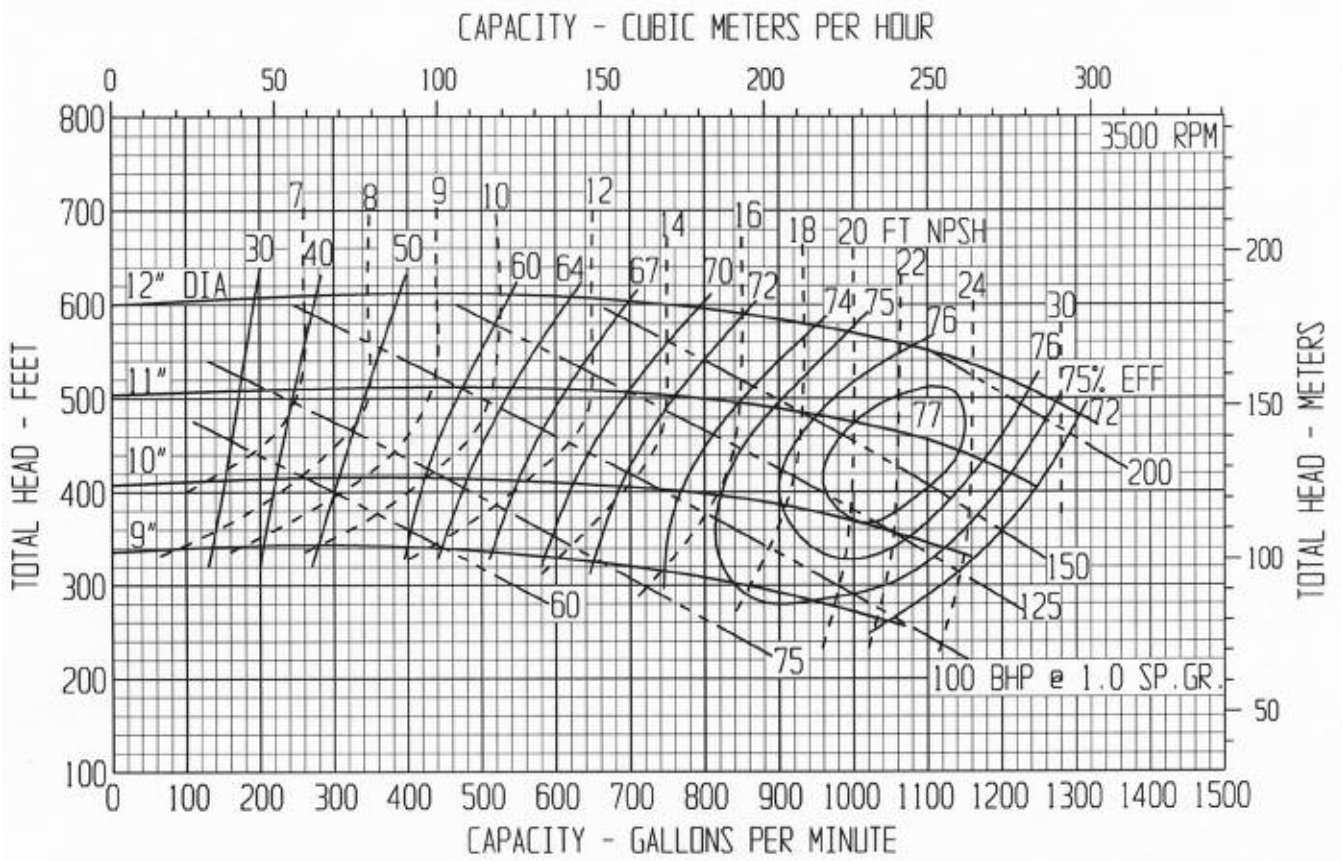

PUMP PERFORMANCE: This curve, based on extensive tests, defines the average performance of this pump for liquids having a viscosity of 70 SSU or less. Actual performance of individual units may differ slightly from the performance indicated on this curve. Pump applications made from the data contained herein are subject to confirmation and acceptance by our Engineering Department at our Indianapolis Office.

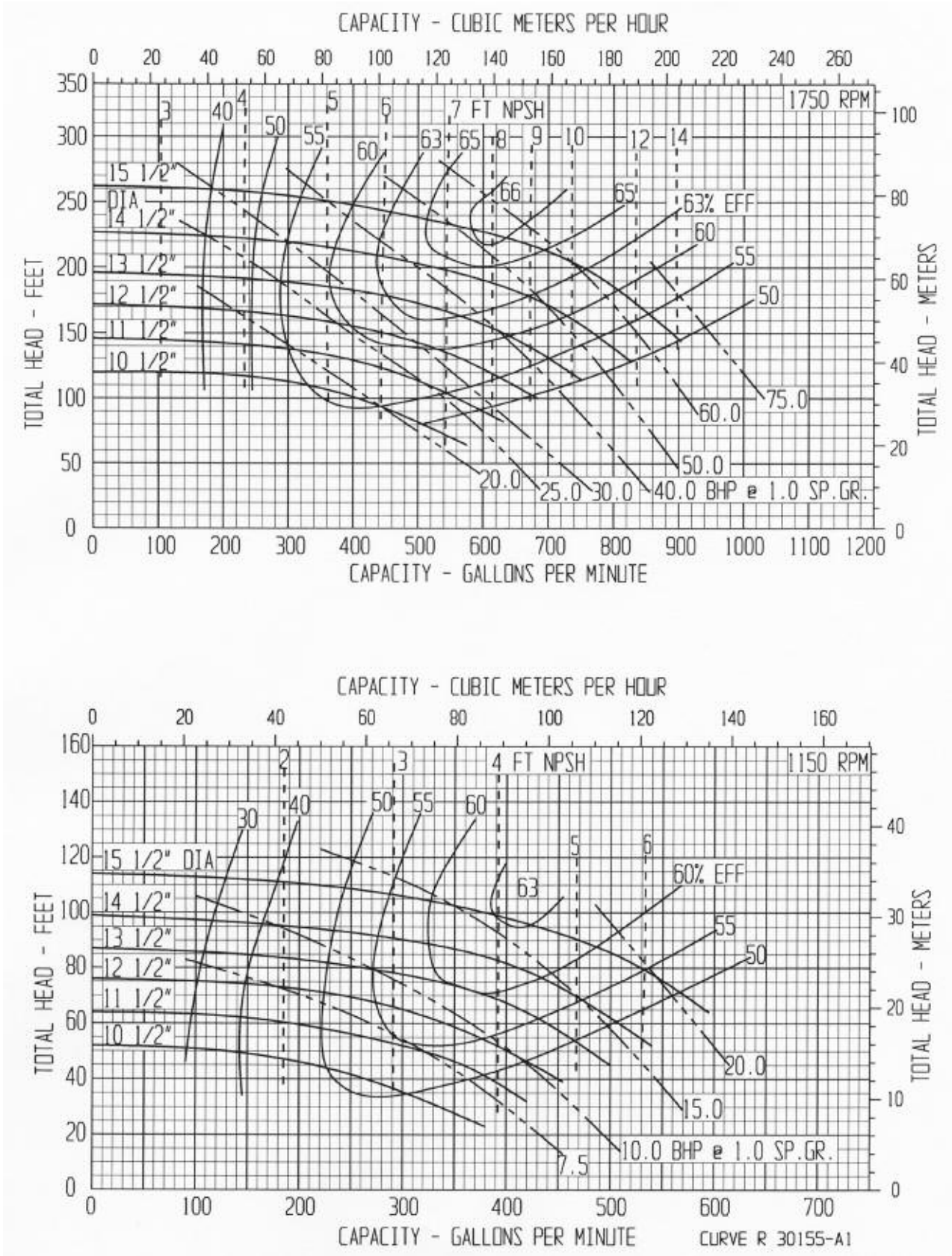

PUMP PERFORMANCE: This curve, based on extensive tests, defines the average performance of this pump for liquids having a viscosity of 70 SSU or less. Actual performance of individual units may differ slightly from the performance indicated on this curve. Pump applications made from the data contained herein are subject to confirmation and acceptance by our Engineering Department at our Indianapolis Office.

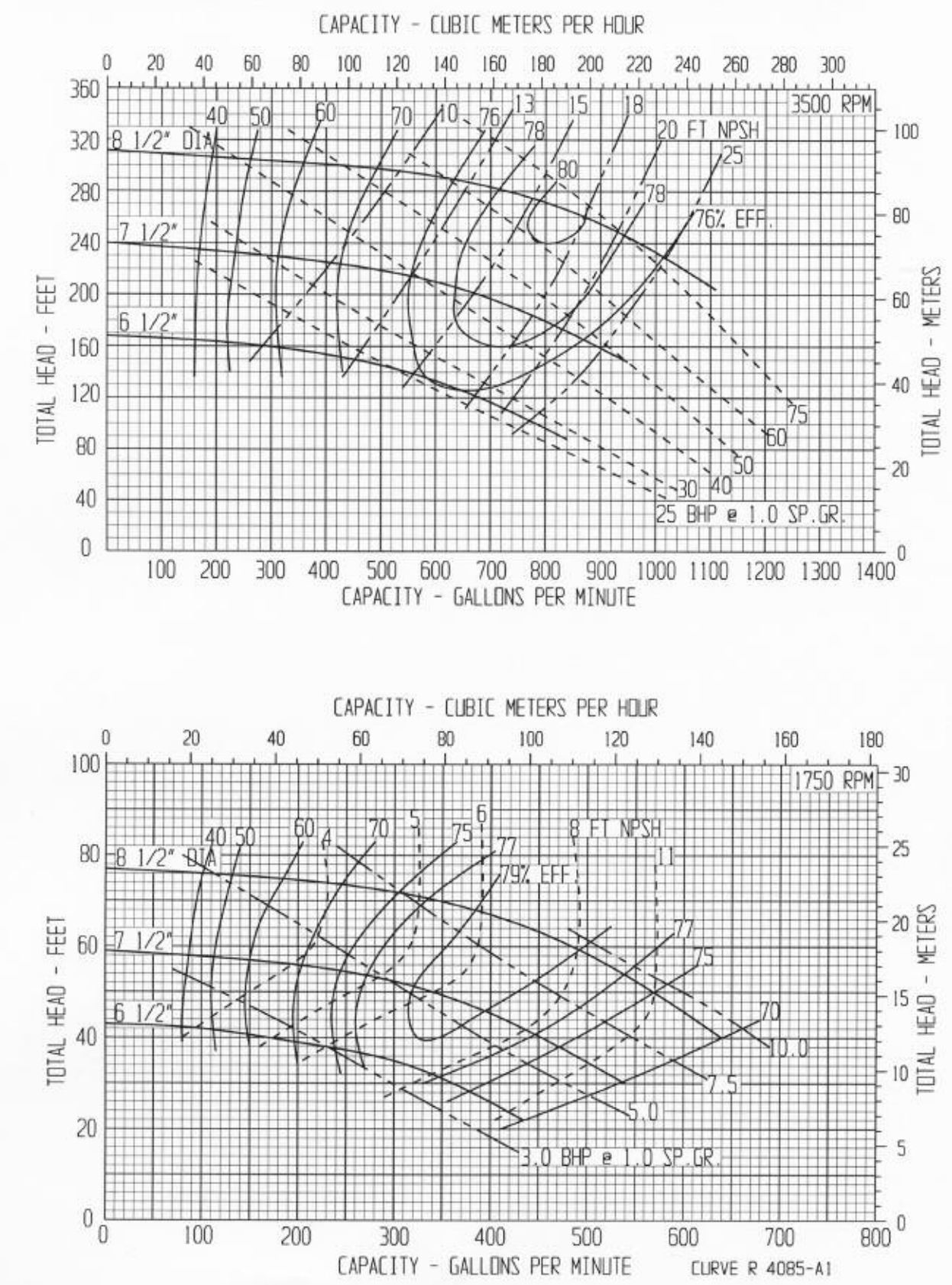

PUMP PERFORMANCE: This curve, based on extensive tests, defines the average performance of this pump for liquids having a viscosity of 70 SSU or less. Actual performance of individual units may differ slightly from the performance indicated on this curve. Pump applications made from the data contained herein are subject to confirmation and acceptance by our Engineering Department at our Indianapolis Office.

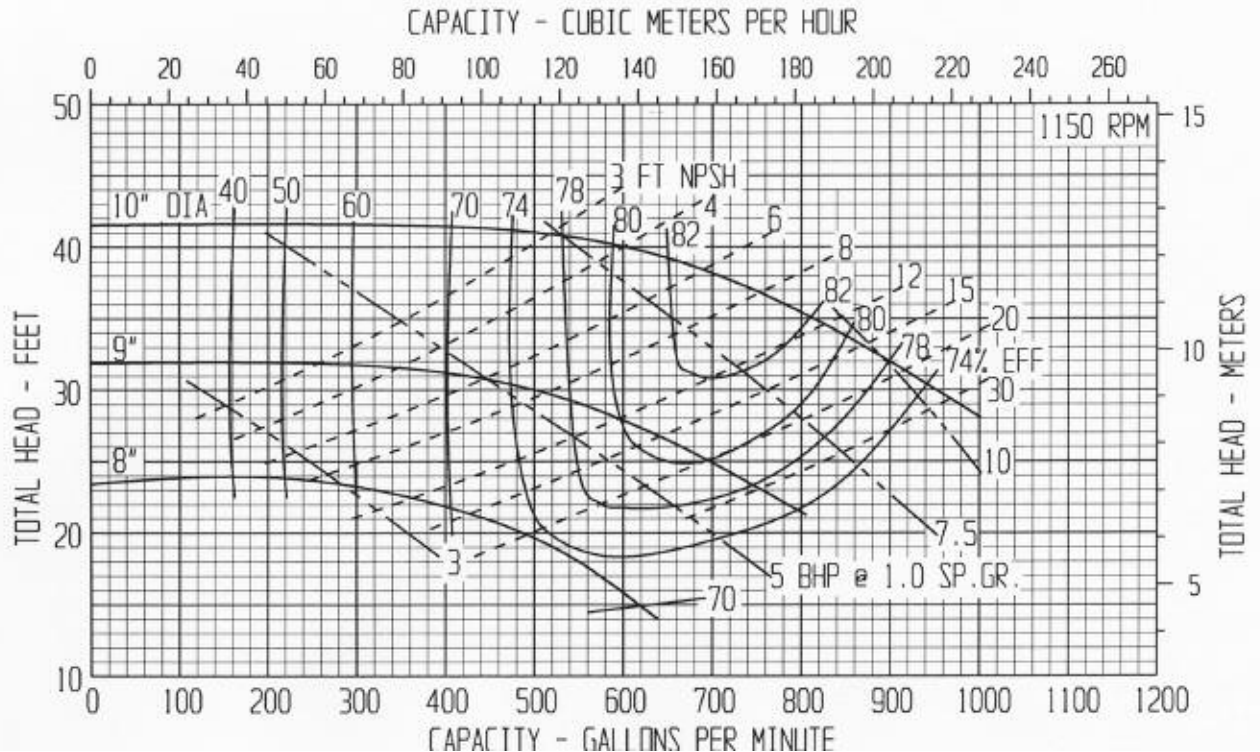
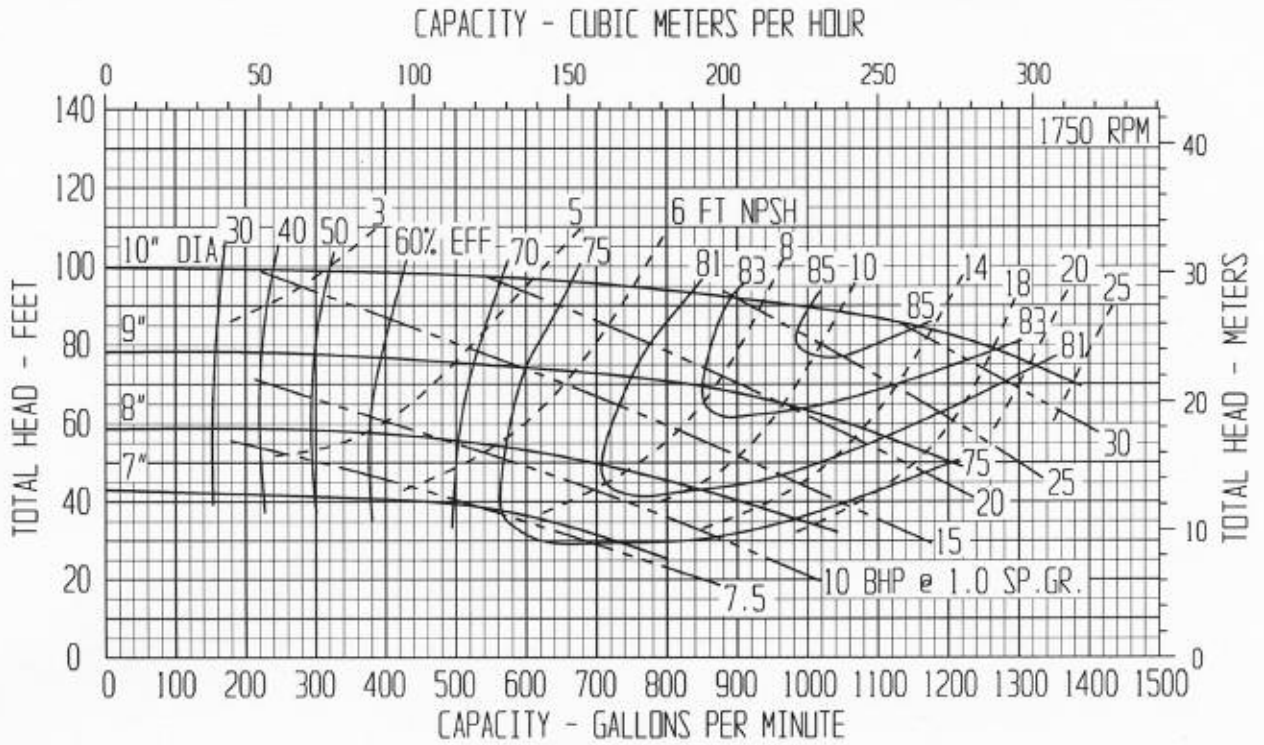

PUMP PERFORMANCE: This curve, based on extensive tests, defines the average performance of this pump for liquids having a viscosity of 70 SSU or less. Actual performance of individual units may differ slightly from the performance indicated on this curve. Pump applications made from the data contained herein are subject to confirmation and acceptance by our Engineering Department at our Indianapolis Office.

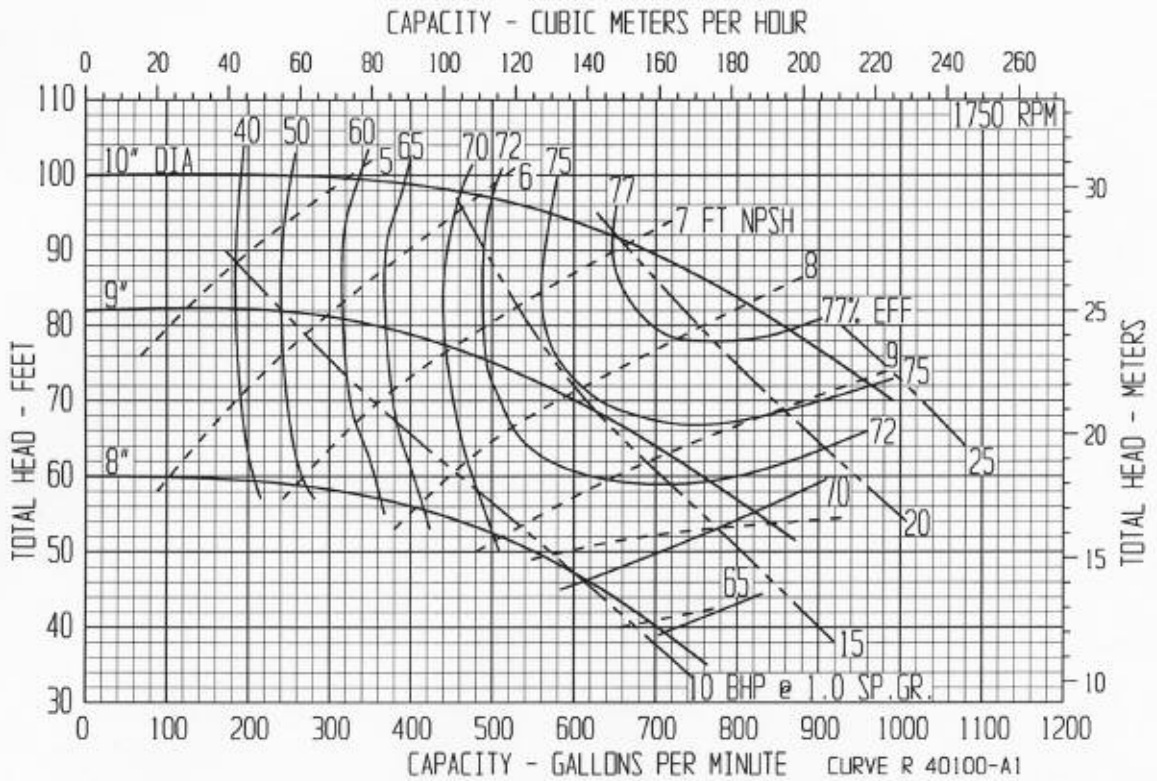
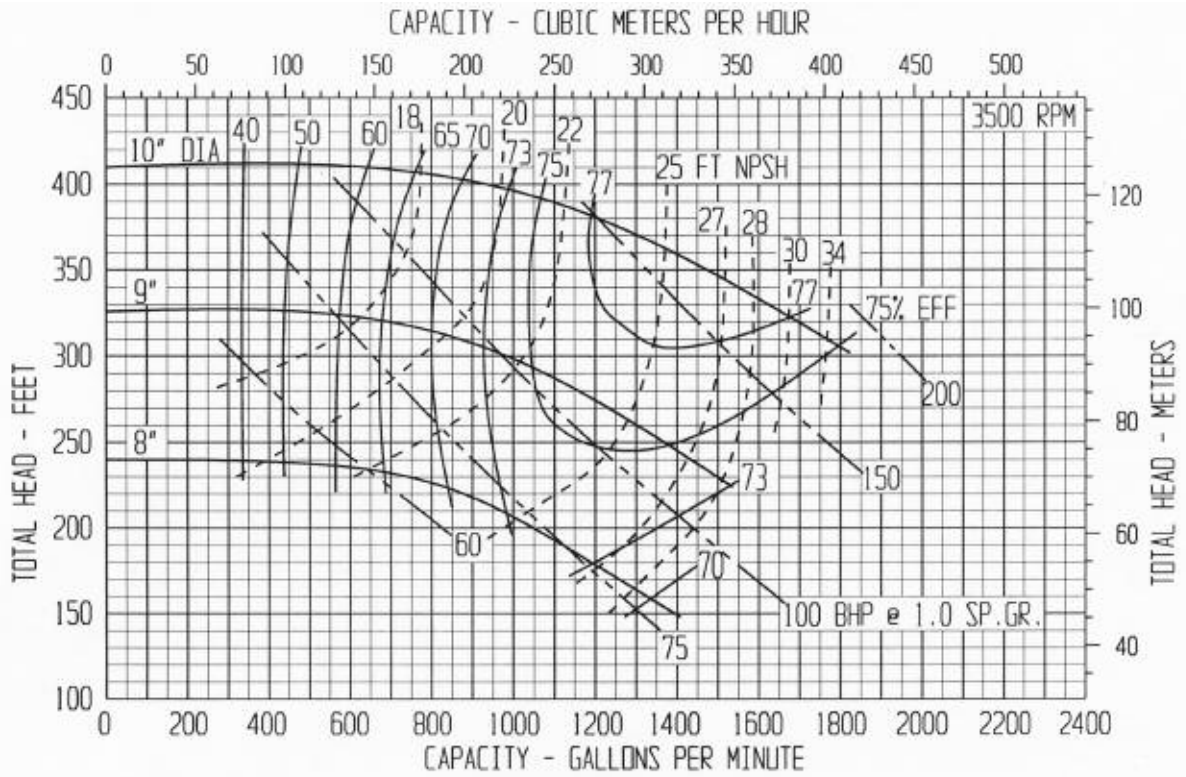

PUMP PERFORMANCE: This curve, based on extensive tests, defines the average performance of this pump for liquids having a viscosity of 70 SSU or less. Actual performance of individual units may differ slightly from the performance indicated on this curve. Pump applications made from the data contained herein are subject to confirmation and acceptance by our Engineering Department at our Indianapolis Office.

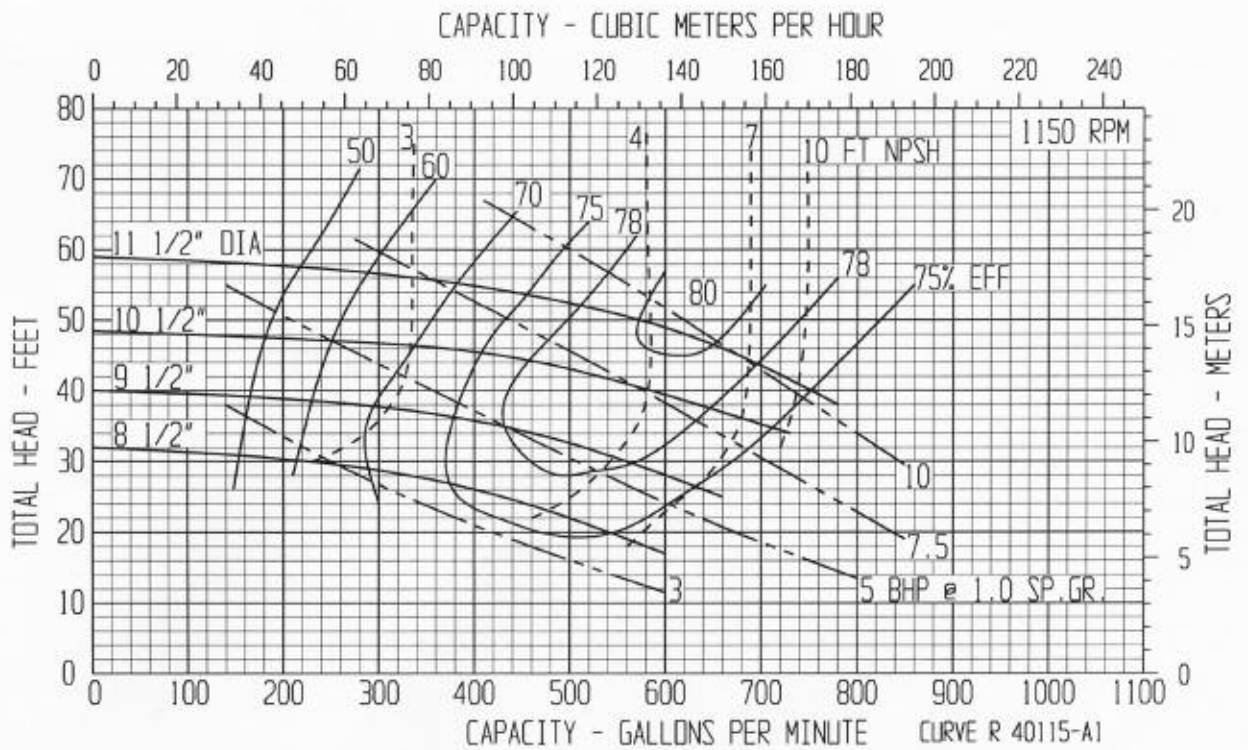
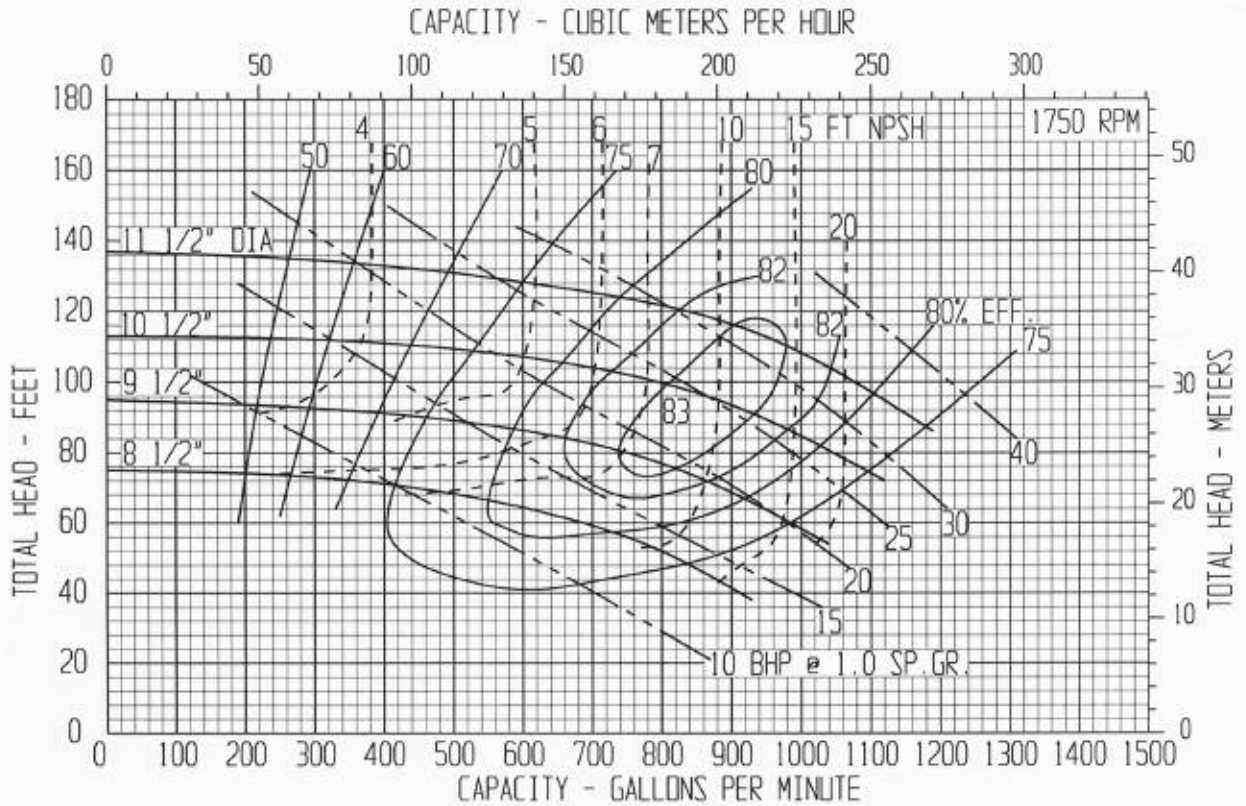

PUMP PERFORMANCE: This curve, based on extensive tests, defines the average performance of this pump for liquids having a viscosity of 70 SSU or less. Actual performance of individual units may differ slightly from the performance indicated on this curve. Pump applications made from the data contained herein are subject to confirmation and acceptance by our Engineering Department at our Indianapolis Office.

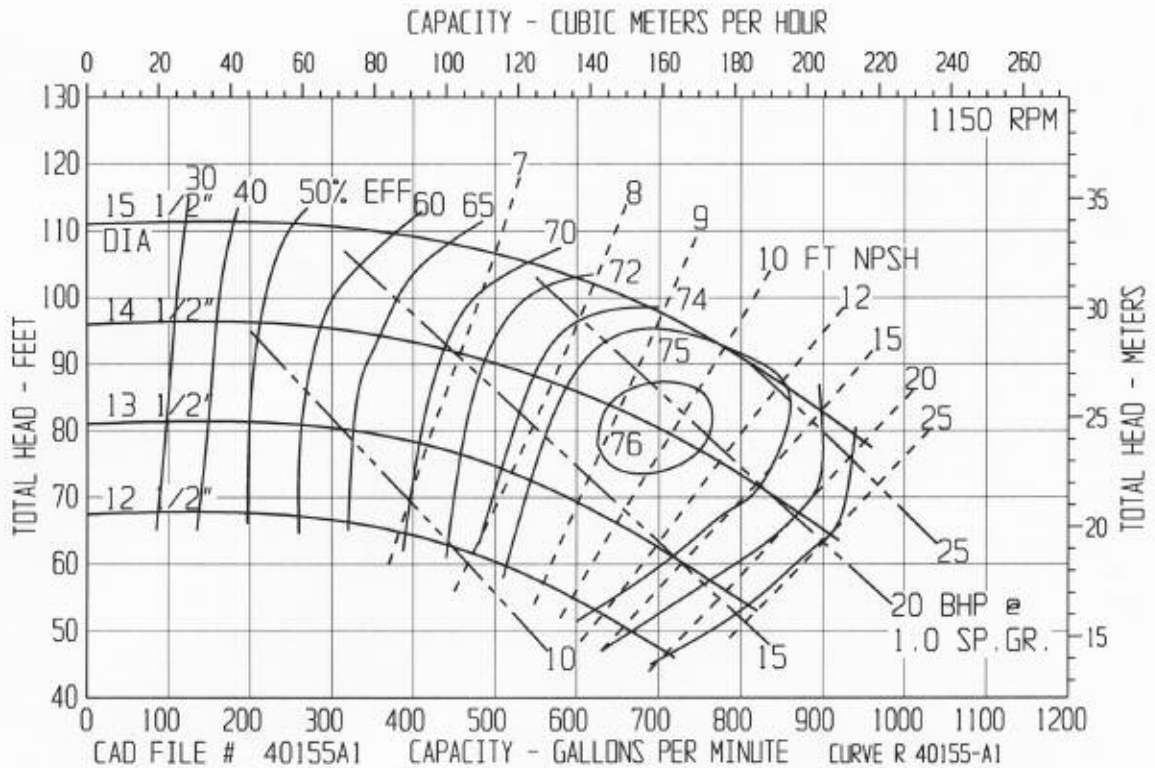
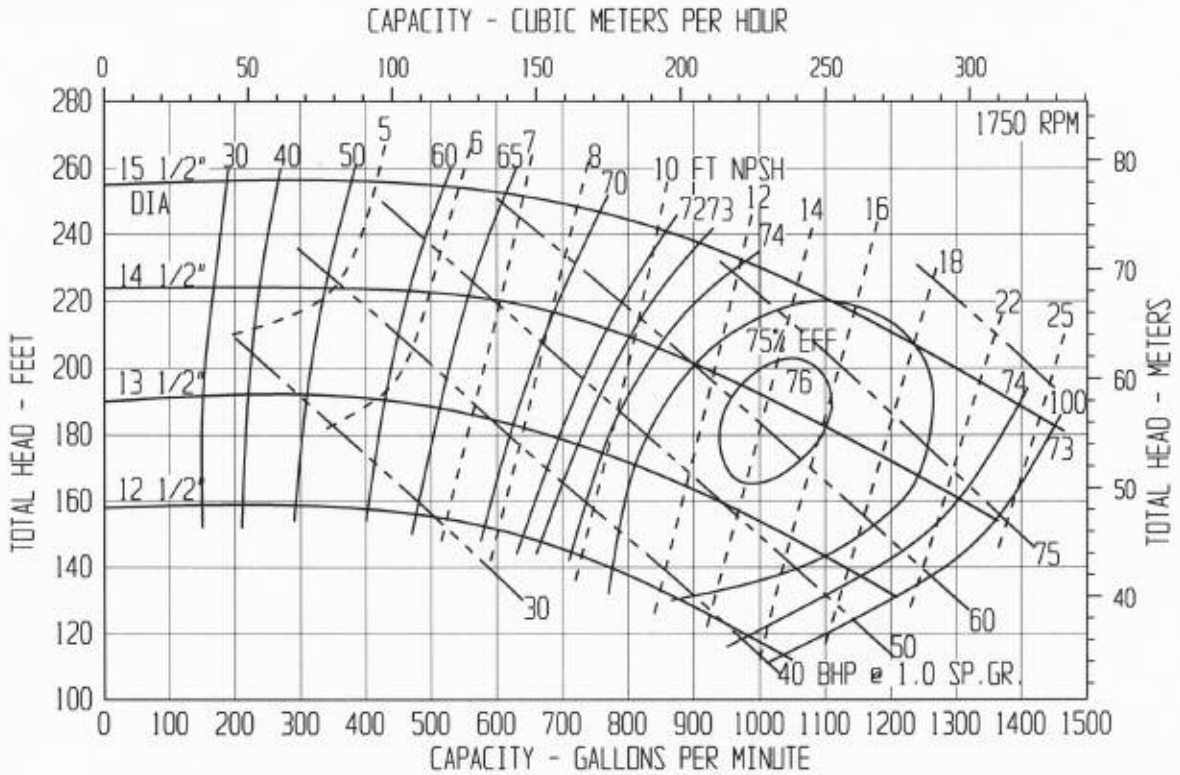

CAD FILE # 40155A1 CAPACITY - GALLONS PER MINUTE CURVE R 40155-A1

PUMP PERFORMANCE: This curve, based on extensive tests, defines the average performance of this pump for liquids having a viscosity of 70 SSU or less. Actual performance of individual units may differ slightly from the performance indicated on this curve. Pump applications made from the data contained herein are subject to confirmation and acceptance by our Engineering Department at our Indianapolis Office.

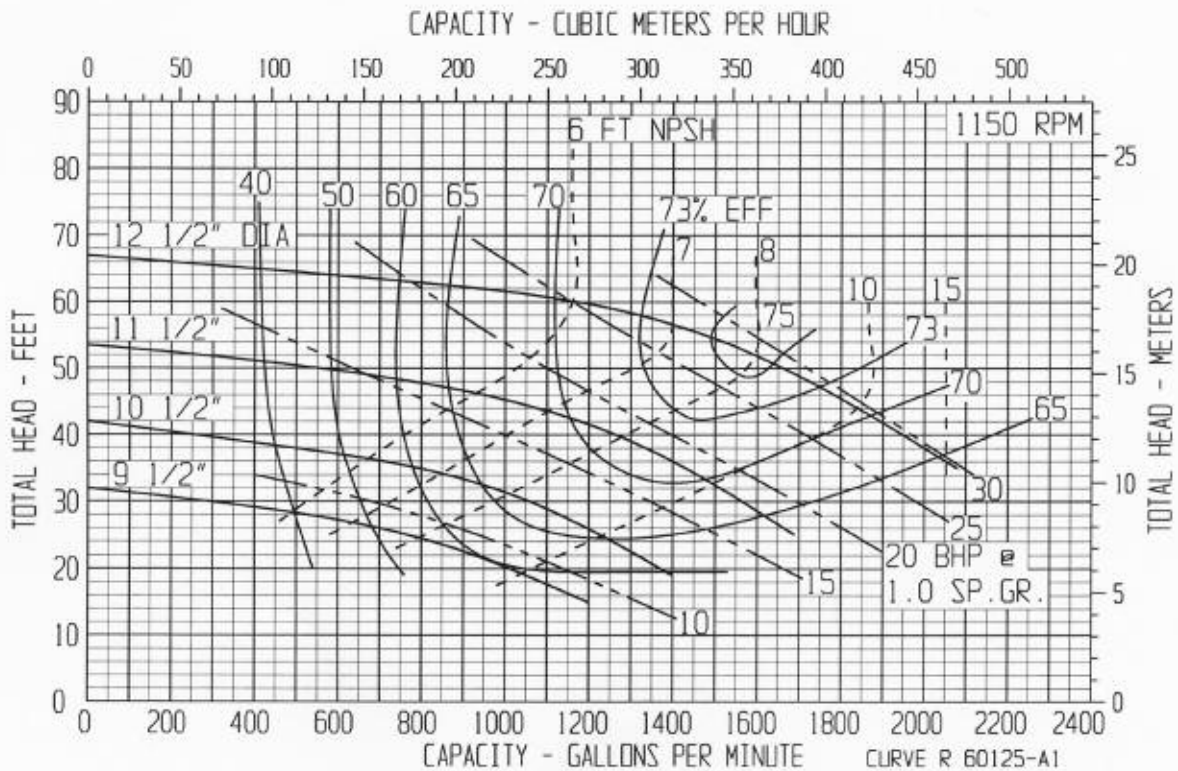
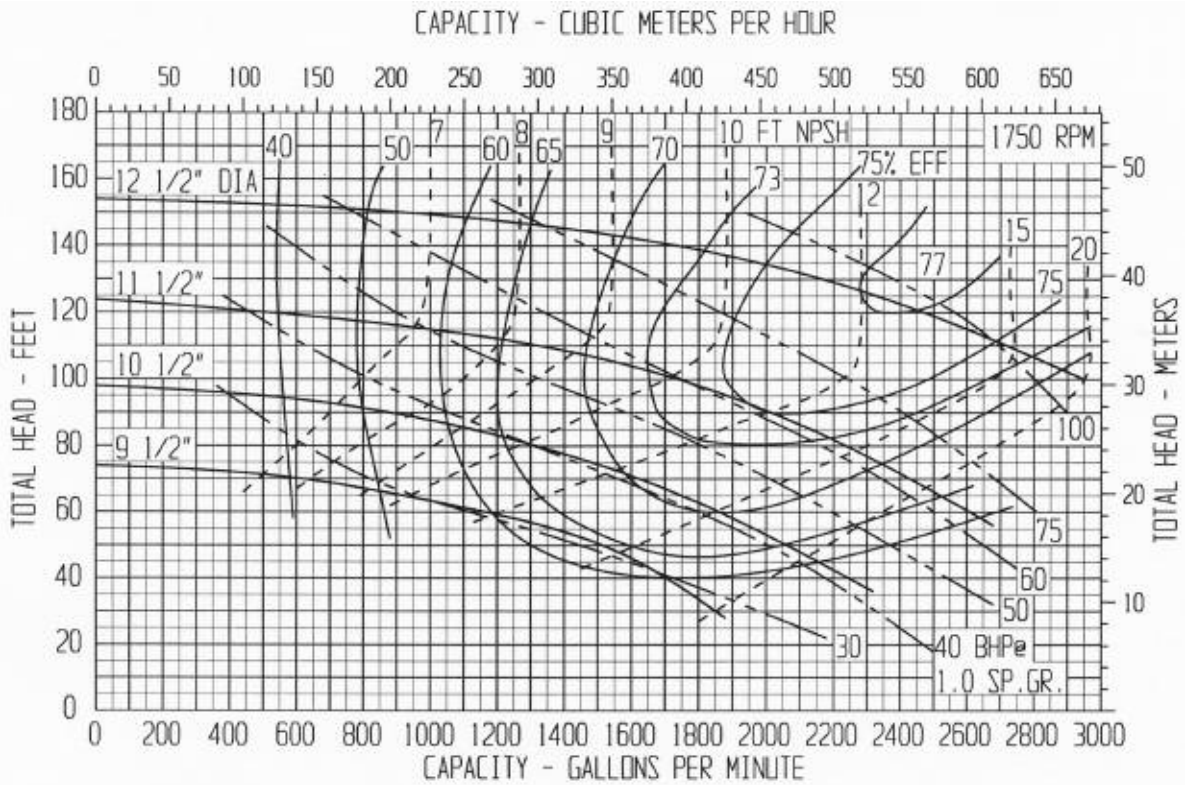

PUMP PERFORMANCE: This curve, based on extensive tests, defines the average performance of this pump for liquids having a viscosity of 70 SSU or less. Actual performance of individual units may differ slightly from the performance indicated on this curve. Pump applications made from the data contained herein are subject to confirmation and acceptance by our Engineering Department at our Indianapolis Office.

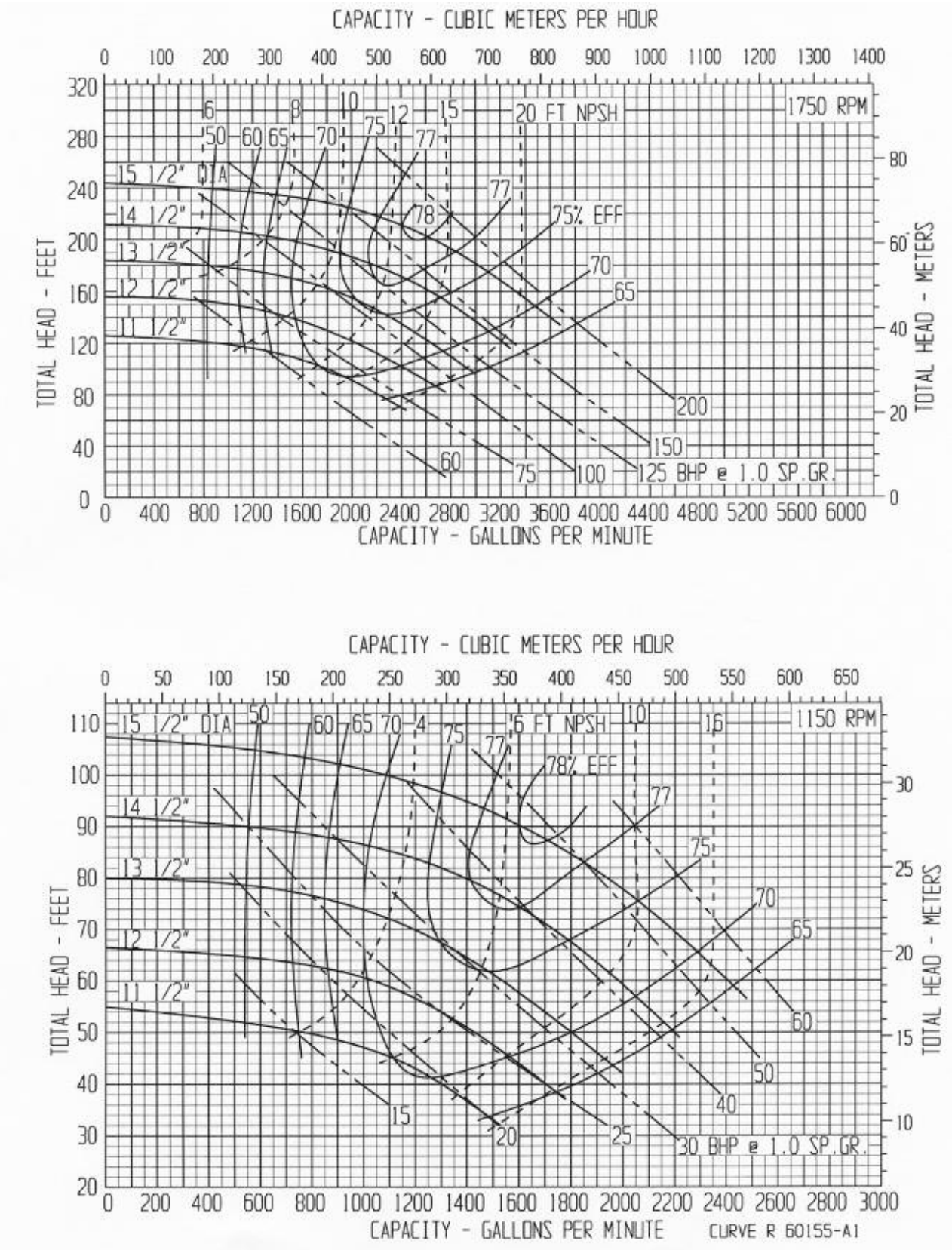

PUMP PERFORMANCE: This curve, based on extensive tests, defines the average performance of this pump for liquids having a viscosity of 70 SSU or less. Actual performance of individual units may differ slightly from the performance indicated on this curve. Pump applications made from the data contained herein are subject to confirmation and acceptance by our Engineering Department at our Indianapolis Office.

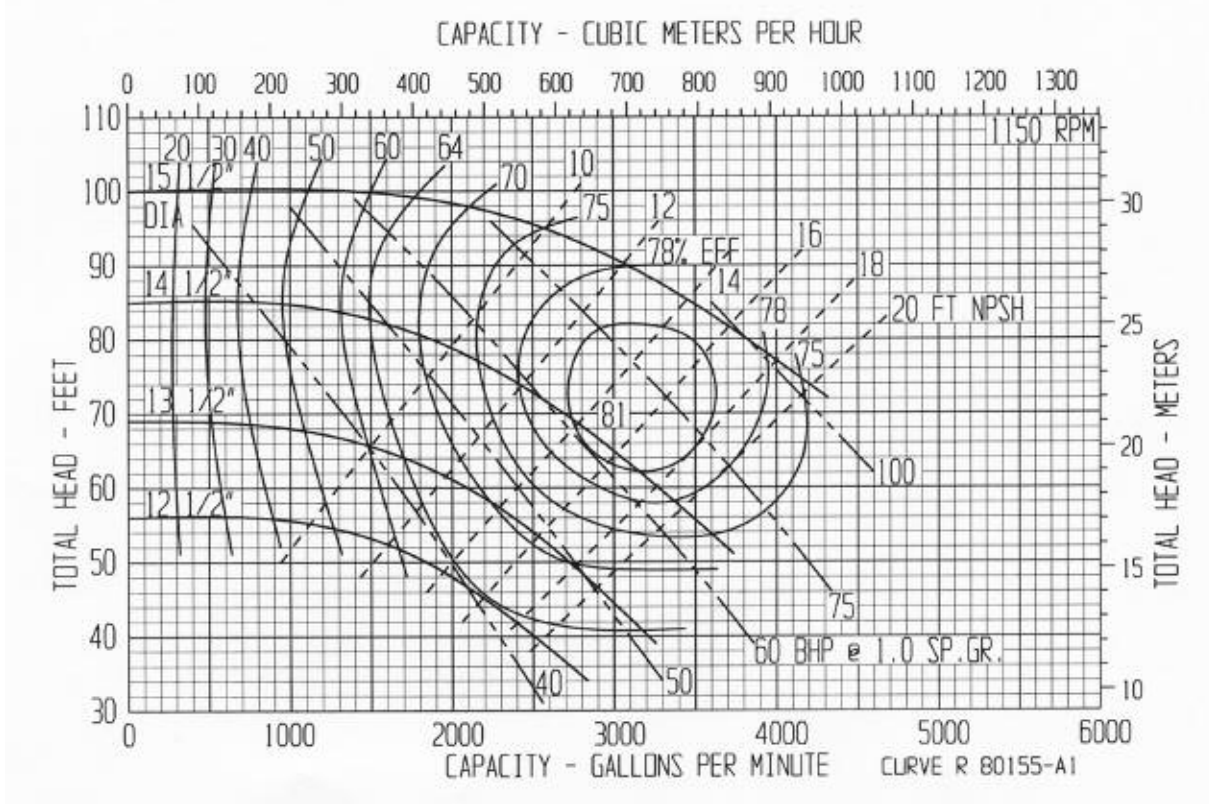
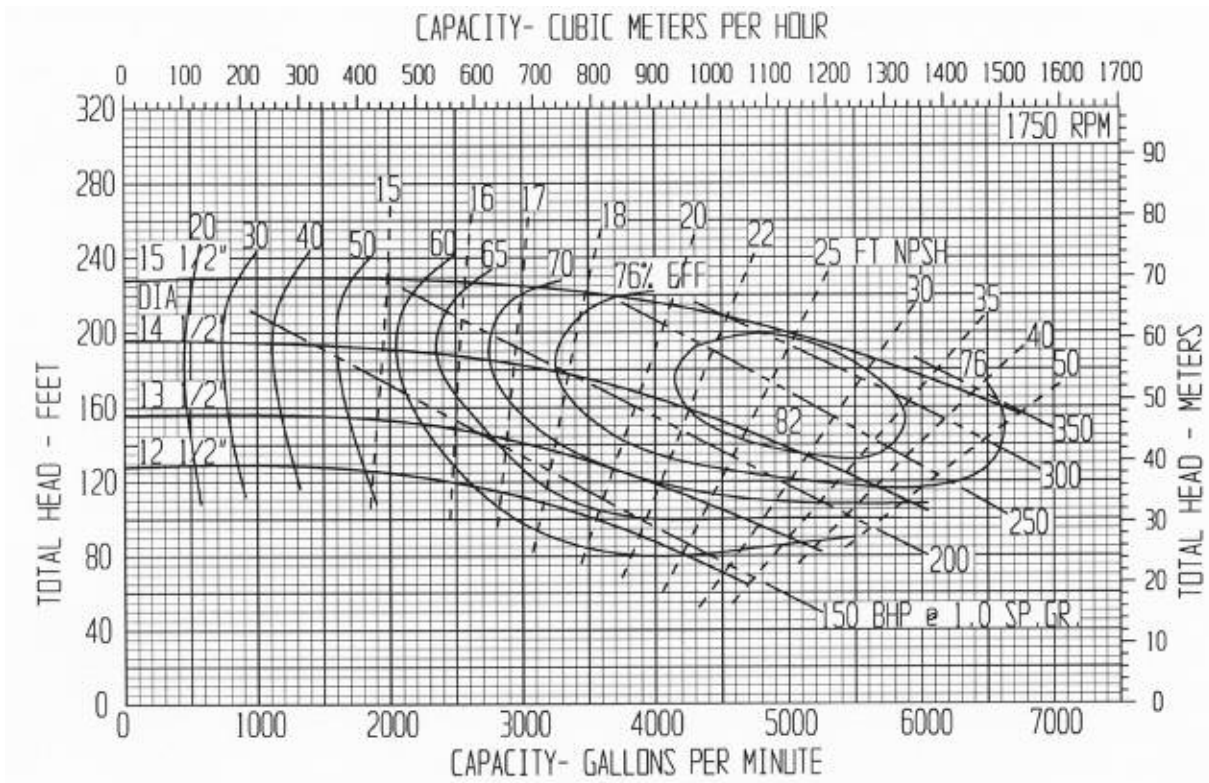



A Met-Pro Fluid Handling Technologies Business
Combining the Resources of **Dean Pump, Fybroc & Sethco**

6040 Guion Road • Indianapolis, IN 46254
(317) 293-2930 • FAX: (317) 297-7028
E-mail: info@deanpump.com • Web Site: www.deanpump.com

