

Installation & Service
G25-991-2400B

Hydra-Cell[®]

INDUSTRIAL PUMPS

Models: G-25, H-25

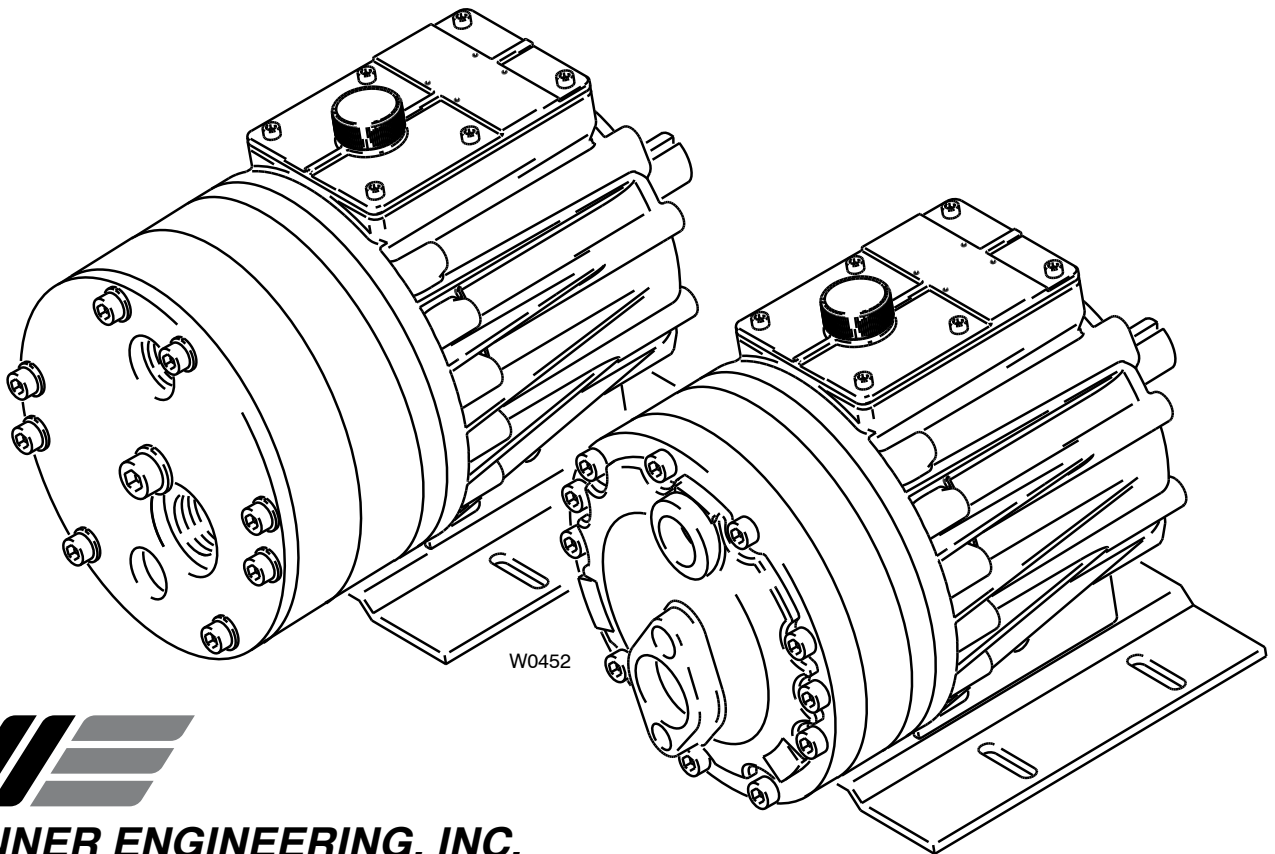

WANNER ENGINEERING, INC.

1204 Chestnut Avenue, Minneapolis, MN 55403
TEL: (612) 332-5681 FAX: (612) 332-6937
TOLL-FREE FAX [US only]: (800) 332-6812

www.hydra-cell.com
email: sales@wannereng.com

G/H-25 Contents

| | Page |
|-------------------------------|------|
| Specifications..... | 2 |
| Dimensions | 4 |
| Installation..... | 5 |
| Maintenance..... | 9 |
| Service (Fluid End) | 10 |
| Service (Hydraulic End) | 15 |
| Troubleshooting..... | 18 |

G/H-25 Specifications

Max Pressure

| | |
|---------------|-------------------|
| Metallic: | 1000 psi (70 bar) |
| Non-Metallic: | 250 psi (17 bar) |

Capacity @ Max Pressure

| | rpm | gpm | l/min |
|----------|------|------|-------|
| G/H-25-X | 1050 | 20.0 | 76 |
| G/H-25-E | 1150 | 20.2 | 77 |
| G/H-25-S | 1150 | 15.6 | 59 |
| G/H-25-I | 1150 | 11.6 | 44 |

Delivery @ Max Pressure

| | revs/gal | revs/liter |
|----------|----------|------------|
| G/H-25-X | 52 | 14 |
| G/H-25-E | 57 | 15 |
| G/H-25-S | 74 | 19 |
| G/H-25-I | 99 | 26 |

| | |
|---------------------------|--------------------------------|
| Max Inlet Pressure | Metallic: 250 psi (17 bar) |
| | Non-Metallic: 50 psi (3.5 bar) |

Max Temperature

| | |
|---------------|---|
| Metallic: | 250°F (121°C) – consult factory for temperatures above 160°F (71°C) |
| Non-Metallic: | Polypropylene 120°F (49°C) Kynar 140°F (60°C) |

| | |
|-------------------|---|
| Inlet Port | H-25: 1-1/2 inch NPT G-25: 1-1/2 inch BSPT |
|-------------------|---|

| | |
|-----------------------|---------------------------------------|
| Discharge Port | H-25: 1 inch NPT G-25: 1 inch BSPT |
|-----------------------|---------------------------------------|

| | |
|-----------------------|-----------------------|
| Shaft Diameter | 1-1/8 inch (28.58 mm) |
|-----------------------|-----------------------|

| | |
|-----------------------|----------------|
| Shaft Rotation | Bi-directional |
|-----------------------|----------------|

| | |
|-----------------|----------------|
| Bearings | Tapered roller |
|-----------------|----------------|

| | |
|---------------------|----------------------------|
| Oil Capacity | 2.5 US quarts (2.4 liters) |
|---------------------|----------------------------|

Weight

| | |
|---------------------|-------------------|
| Metallic Heads: | 125 lbs (56.8 kg) |
| Non-Metallic Heads: | 90 lbs (40.9 kg) |

Calculating Required Horsepower (kW)*

$$\frac{50 \times \text{rpm}}{63,000} + \frac{\text{gpm} \times \text{psi}}{1,460} = \text{electric motor HP}^*$$

$$\frac{50 \times \text{rpm}}{84,428} + \frac{\text{lpm} \times \text{bar}}{511} = \text{electric motor kW}^*$$

* rpm equals pump shaft rpm. HP/kW is required application power. Use caution when sizing motors with variable speed drives.

G/H-25 Specifications

Performance

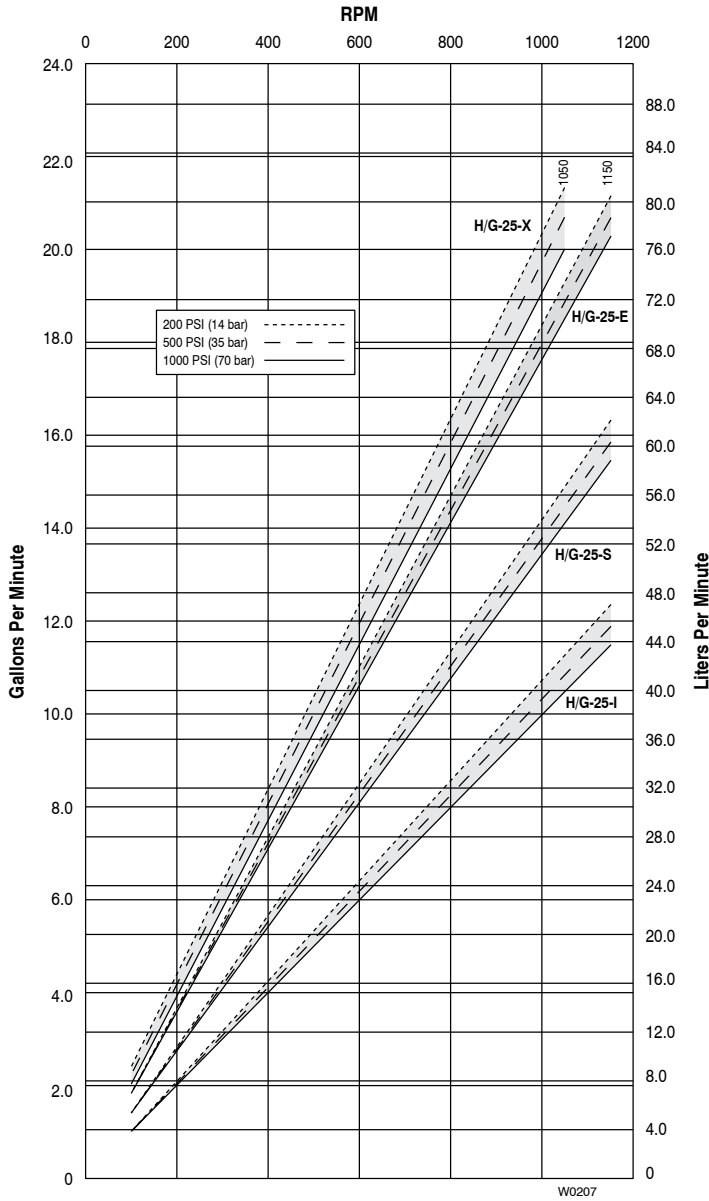

Net Positive Suction Head – NPSHr

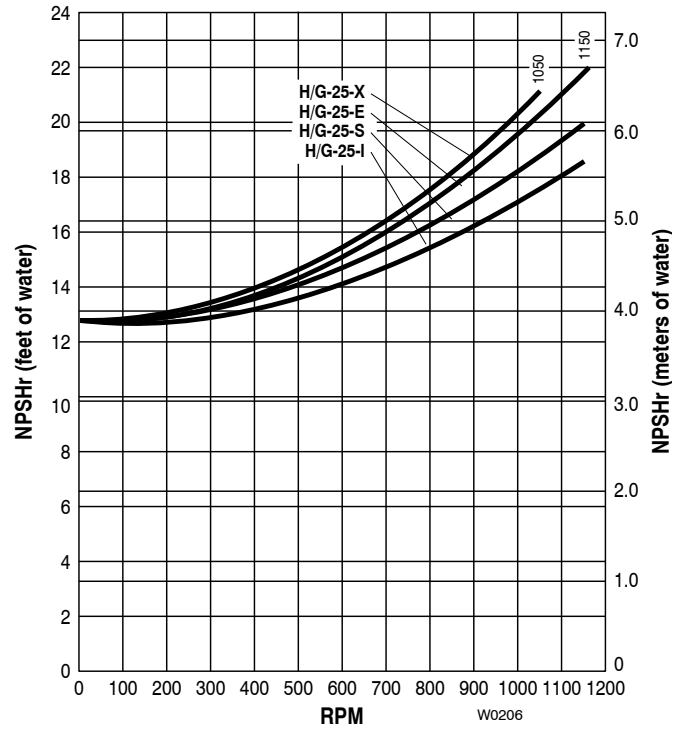

Dry Lift

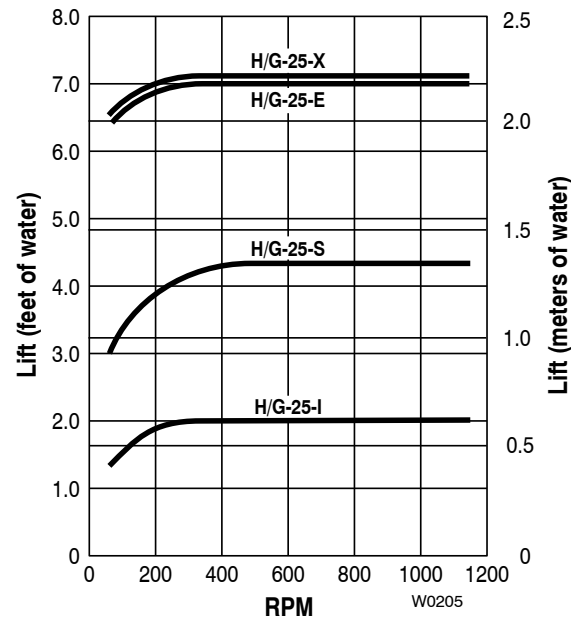

G/H-25 Dimensions

Models with Metallic Pumping Head

Brass

Cast Iron

316 Stainless Steel

Nickel Alloy (Hastelloy CW12MW)

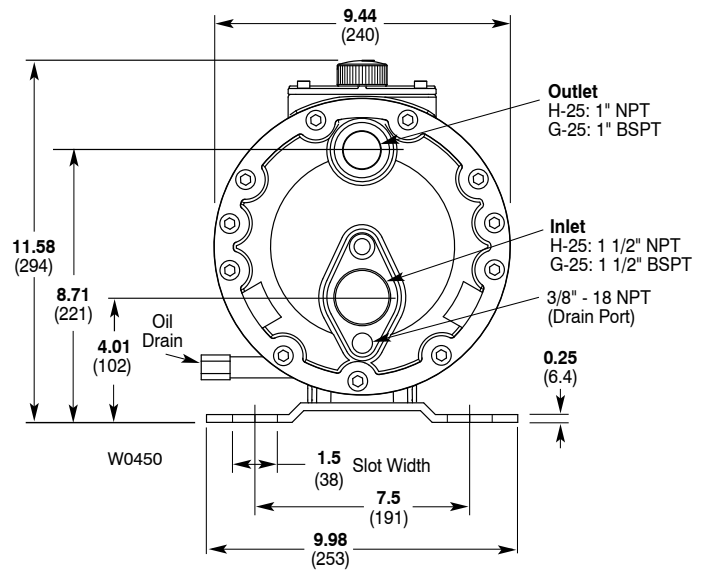
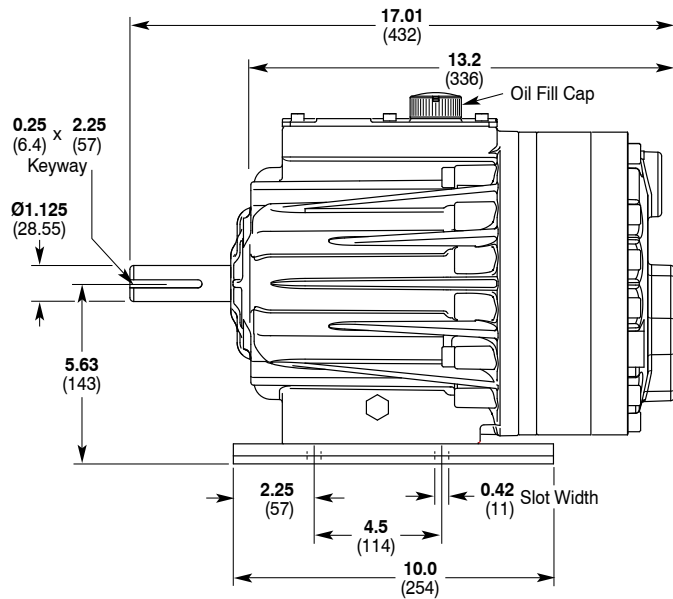

Models with Non-metallic Pump Head

Kynar®

Polypropylene

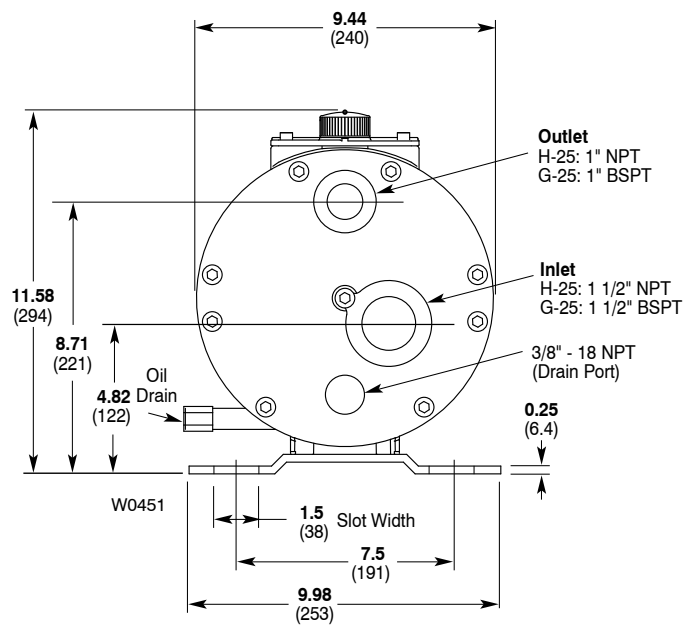
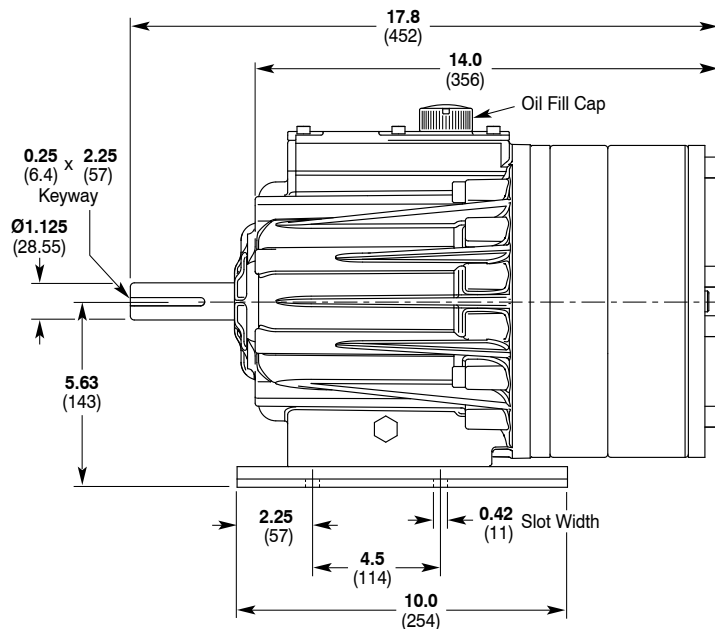

G/H-25 Installation

Location

NOTE: The numbers in parentheses are the Reference Numbers on the exploded view illustrations found later in this manual and in the Parts Manual.

Locate the pump as close to the supply source as possible.

Install it in a lighted, clean space where it will be easy to inspect and maintain. Allow room for checking the oil level, changing the oil, and removing the pump head (manifold, valve plate and related items).

Mounting

The pump shaft can be rotated in either direction.

To prevent vibration, securely attach the pump and motor to a level, rigid base.

On a belt-drive system, align the sheaves accurately: poor alignment wastes horsepower and shortens the belt and bearing life. Make sure the belts are properly tightened, as specified by the belt manufacturer.

On a direct-drive system, align the shafts accurately. Unless otherwise specified by the coupling manufacturer, maximum parallel misalignment should not exceed 0.015 in. (0.4 mm) and angular misalignment should be held to 1° maximum. Careful alignment extends life of the coupling, pump, shafts, and support bearings. Consult coupling manufacturer for exact alignment tolerances.

Important Precautions

Adequate Fluid Supply. To avoid cavitation and premature pump failure, be sure that the pump will have an adequate fluid supply and that the inlet line will not be obstructed. See "Inlet Piping".

Positive Displacement. This is a positive-displacement pump. To avoid severe system damage if the discharge line ever becomes blocked, install a relief valve downstream from the pump. See "Discharge Piping".

Safety Guards. Install adequate safety guards over all pulleys, belts, and couplings. Follow all codes and regulations regarding installation and operation of the pumping system.

Shut-Off Valves. Never install shut-off valves between the pump and discharge pressure regulator, or in the regulator bypass line.

Freezing Conditions. Protect the pump from freezing. See also the Maintenance Section.

Consult the Factory for the following situations:

- Extreme temperature applications – above 160° F (71° C) or below 40° F (5° C)
- Pressure feeding of pumps
- Viscous or abrasive fluid applications
- Chemical compatibility problems
- Hot ambient temperatures – above 110° F (43° C)
- Conditions where pump oil may exceed 200° F (93° C) because of a combination of hot ambient temperatures, hot fluid temperature, and full horsepower load — an oil cooler may be required.

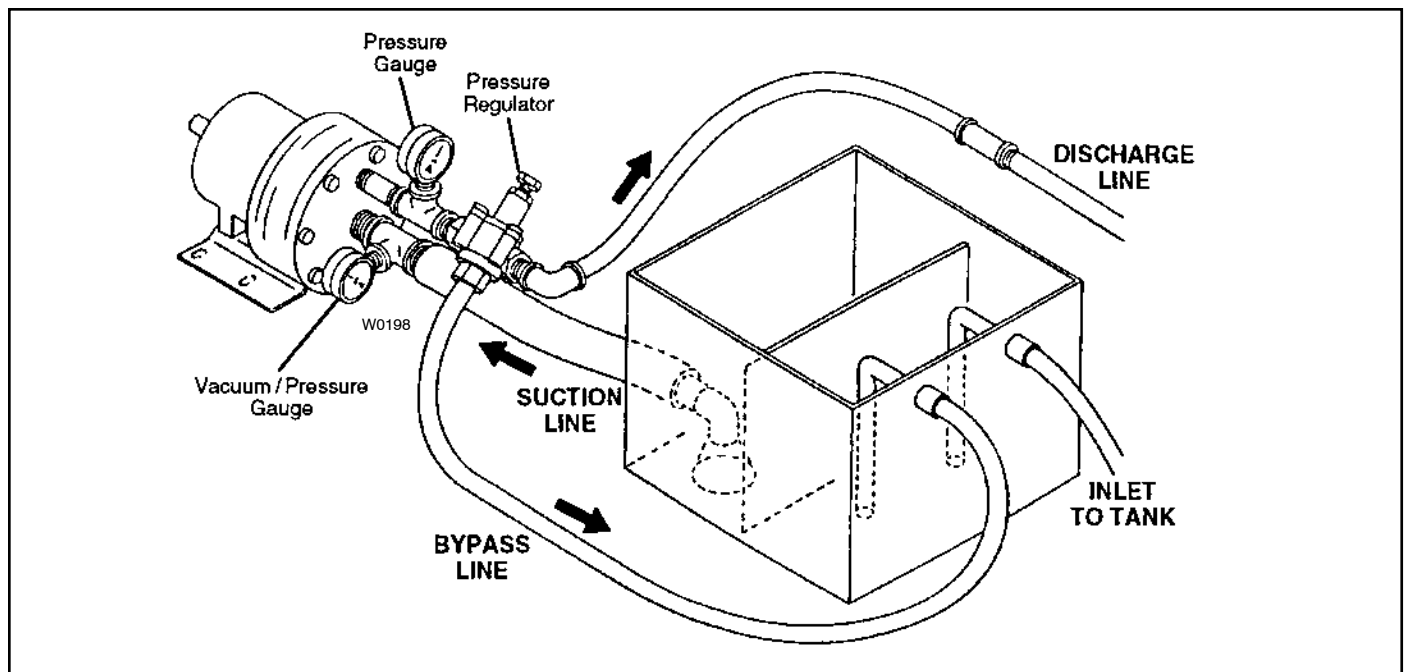

G/H-25 Installation

Inlet Piping (Suction Feed)

CAUTION: When pumping at temperatures above 160° F (71° C), use a pressure-feed system.

Install draincocks at any low points of the suction line, to permit draining in freezing conditions.

Provide for permanent or temporary installation of a vacuum gauge to monitor the inlet suction. To maintain maximum flow, vacuum at the pump inlet should not exceed 7 in. Hg at 70° F (180 mm Hg at 21° C). **Do not supply more than one pump from the same inlet line.**

Supply Tank

Use a supply tank that is large enough to provide time for any trapped air in the fluid to escape. The tank size should be at least twice the maximum pump flow rate.

Isolate the pump and motor stand from the supply tank, and support them separately.

Install a separate inlet line from the supply tank to each pump.

Install the inlet and bypass lines so they empty into the supply tank below the lowest water level, on the opposite side of the baffle from the pump suction line.

If a line strainer is used in the system, install it in the inlet line to the supply tank.

To reduce aeration and turbulence, install a completely submerged baffle plate to separate the incoming and outgoing liquids.

Install a vortex breaker in the supply tank, over the outlet port to the pump.

Place a cover over the supply tank, to prevent foreign objects from falling into it.

Hose and Routing

Size the suction line at least one size larger than the pump inlet, and so that the velocity will not exceed 1-3 ft/sec (0.3 to 0.9 m/s):

For pipe in inches: Velocity (ft/sec) = 0.408 x GPM/Pipe ID²

For pipe in mm: Velocity (m/sec) = 21.2 x LPM/Pipe ID²

Keep the suction line as short and direct as possible. A maximum of 3 feet (1 m) is recommended.

Use flexible hose and/or expansion joints to absorb vibration, expansion, or contraction.

If possible, keep the suction line level. Do not have any high points to collect vapor unless these high points are vented.

To reduce turbulence and resistance, do not use 90° elbows. If turns are necessary in the suction line, use 45° elbows or arrange sweeping curves in the flexible inlet hose.

If a block valve is used, be sure it is fully opened so that the flow to the pump is not restricted. The opening should be at least the same diameter as the inlet plumbing ID.

Do not use a line strainer or filter in the suction line unless regular maintenance is assured. If used, it should have a free-flow area of at least three times the free-flow area of the inlet.

Install piping supports where necessary to relieve strain on the inlet line and to minimize vibration.

Inlet Piping (Pressure Feed)

Provide for permanent or temporary installation of a vacuum/pressure gauge to monitor the inlet vacuum or pressure. Pressure at the pump inlet should not exceed 250 psi (17 bar); if it could get higher, install an inlet pressure reducing regulator.

Do **not** supply more than one pump from the same inlet line.

Inlet Calculations

Acceleration Head

Calculating the Acceleration Head

Use the following formula to calculate acceleration head losses. Subtract this figure from the NPSHa, and compare the result to the NPSHr of the Hydra-Cell pump.

$$H_a = (L \times V \times N \times C) \div (K \times G)$$

where:

H_a = Acceleration head (ft of liquid)

L = Actual length of suction line (ft) — not equivalent length

V = Velocity of liquid in suction line (ft/sec)

$$[V = \text{GPM} \times (0.408 \div \text{pipe ID}^2)]$$

N = RPM of crank shaft

C = Constant determined by type of pump — use 0.066 for the H-25 and G-25 Hydra-Cell pumps

K = Constant to compensate for compressibility of the fluid — use: 1.4 for de-aerated or hot water; 1.5 for most liquids; 2.5 for hydrocarbons with high compressibility

G = Gravitational constant (32.2 ft/sec²)

Friction Losses

Calculating Friction Losses in Suction Piping

When following the above recommendations (under “Inlet Piping”) for minimum hose/pipe I.D. and maximum length, frictional losses in the suction piping are negligible (i.e., H_f = 0) if you are pumping a water-like fluid.

When pumping more-viscous fluids such as lubricating oils, sealants, adhesives, syrups, varnishes, etc., frictional losses in the suction piping may become significant. As H_f increases, the available NPSH (NPSHa) will decrease, and cavitation will occur.

In general, frictional losses increase with increasing viscosity, increasing suction-line length, increasing pump flow rate, and decreasing suction-line diameter. Changes in suction-line diameter have the greatest impact on frictional losses: a 25% increase in suction-line diameter cuts losses by more than two times, and a 50% increase cuts losses by a factor of five times.

Consult the factory before pumping viscous fluids.

Loctite is a registered trademark of Loctite Corporation.
Scotchbrite is a registered trademark of 3M Company.

G/H-25 Installation

Minimizing Acceleration Head and Frictional Losses

To minimize the acceleration head and frictional losses:

- Keep inlet lines less than 3 ft (1 m) long
- Use at least 1-1/2 in. (38 mm) I.D. inlet hose
- Use soft hose (low-pressure hose, non collapsing) for the inlet lines
- Minimize fittings (elbows, valves, tees, etc.)
- **Use a suction stabilizer on the inlet.**

Net Positive Suction Head

NPSHa must be equal to or greater than NPSHr. If not, the pressure in the pump inlet will be lower than the vapor pressure of the fluid — and cavitation will occur.

Calculating the NPSHa

Use the following formula to calculate the NPSHa:

$$\text{NPSHa} = P_t + H_z - H_f - H_a - P_{vp}$$

where:

P_t = Atmospheric pressure

H_z = Vertical distance from surface liquid to pump centerline (if liquid is below pump centerline, the H_z is negative)

H_f = Friction losses in suction piping

H_a = Acceleration head at pump suction

P_{vp} = Absolute vapor pressure of liquid at pumping temperature

NOTES:

- In good practice, NPSHa should be 2 ft greater than NPSHr
- All values must be expressed in feet of liquid

Atmospheric Pressure at Various Altitudes

| Altitude (ft) | Pressure (ft of H ₂ O) | Altitude (ft) | Pressure (ft of H ₂ O) |
|---------------|-----------------------------------|---------------|-----------------------------------|
| 0 | 33.9 | 1500 | 32.1 |
| 500 | 33.3 | 2000 | 31.5 |
| 1000 | 32.8 | 5000 | 28.2 |

Discharge Piping

NOTE: Consult the Factory before manifolding two or more pumps together.

Hose and Routing

Use the shortest, most-direct route for the discharge line.

Select pipe or hose with a **working pressure** rating of at least 1.5 times the maximum system pressure. EXAMPLE: Select a 1500-psi W.P.-rated hose for systems to be operated at 1000-psi-gauge pressure.

Use about 6 ft (1.8 m) of flexible hose between the pump and rigid piping to absorb vibration, expansion or contraction.

Support the pump and piping independently. Size the discharge line so that the velocity of the fluid will not exceed 7-10 ft/sec (2-3 m/sec):

$$\text{For pipe in inches: Velocity (ft/sec)} = 0.408 \times \text{GPM/Pipe ID}^2$$

$$\text{For pipe in mm: Velocity (m/sec)} = 21.2 \times \text{LPM/Pipe ID}^2$$

Pressure Regulation

Install a pressure regulator or unloader in the discharge line. Bypass pressure must not exceed the pressure limit of the pump.

Size the regulator so that, when fully open, it will be large enough to relieve the full capacity of the pump without overpressurizing the system.

Locate the valve as close to the pump as possible and ahead of any other valves.

Adjust the pressure regulating valve to no more than 10% over the maximum working pressure of the system. Do not exceed the manufacturer's pressure rating for the pump or regulator.

Route the bypass line to the supply tank, or to the suction line as far as possible from the pump (to reduce the chance of turbulence and cavitation).

If the pump may be run for a long time with the discharge closed and fluid bypassing, install a thermal protector in the bypass line (to prevent severe temperature buildup in the bypassed fluid).

CAUTION: Never install shutoff valves in the bypass line or between the pump and pressure regulator or relief valve.

Provide for permanent or temporary installation of a pressure gauge to monitor the discharge pressure at the pump.

For additional system protection, install a safety relief valve in the discharge line, downstream from the pressure regulator.

G/H-25 Installation

Before Initial Start-Up

Before you start the pump, be sure that:

- All shutoff valves are open, and the pump has an adequate supply of fluid.
- All connections are tight.
- The oil level is 1/4 in. (6 mm) above the cast surface in the upper oil reservoir.
- The relief valve on the pump outlet is adjusted so the pump starts under minimum pressure.
- All pulleys and belts are properly aligned, and belts are tensioned according to specification.
- All pulleys, belts and shaft couplings have adequate safety guards.

Initial Start-Up Procedure

1. Turn on power to the pump motor.
2. Check the inlet pressure or vacuum. To maintain maximum flow, inlet vacuum must not exceed 7 in. Hg at 70° F (180 mm Hg at 21° C). Inlet pressure must not exceed 250 psi (17 bar).
3. Listen for any erratic noise, and look for unsteady flow. If the pump does not clear, refer to the Troubleshooting Section.
4. If the system has an air lock and the pump fails to prime:
 - a. Turn off the power.
 - b. Remove the pressure gauge or plug from the tee fitting at the pump outlet (refer to the illustration on page 5).

NOTE: Fluid may come out of this port when the plug is removed. Provide an adequate catch basin for fluid spillage, if required. Fluid will come out of this port when the pump is started, so we recommend that you attach adequate plumbing from this port so fluid will not be sprayed or lost. Use high-pressure-rated hose and fittings from this port. Take all safety precautions to assure safe handling of the fluid being pumped.

- c. Jog the system on and off until the fluid coming from this port is air-free.
 - d. Turn off the power.
 - e. Remove the plumbing that was temporarily installed, and reinstall the pressure gauge or plug.
5. Adjust the discharge pressure regulator to the desired operating and bypass pressures. Do not exceed the maximum pressure rating of the pump.
 6. After the pressure regulator is adjusted, set the safety relief valve at 100 psi (7 bar) higher than the desired operating pressure. To verify this setting, adjust the discharge pressure regulator upward until the relief valve opens. Follow the recommendations in the above NOTE (step 4b) for handling the fluid that will come from the relief valve.
 7. Reset the discharge pressure regulator to the desired system pressure.
 8. Provide a return line from the relief valve to the supply tank, similar to the bypass line from the pressure regulator.

G/H-25 Maintenance

NOTE: The numbers in parentheses are the Reference Numbers on the exploded view illustrations found in this manual and in the Parts Manual.

Daily

Check the oil level and the condition of the oil. The oil level should be 1/4 in. (6 mm) above the cast surface in the upper oil reservoir.

Use the appropriate Hydra-Oil for the application (contact Wanner Engineering if in doubt).

CAUTION: If you are losing oil but don't see any external leakage, or if the oil becomes discolored and contaminated, one of the diaphragms (22) may be damaged. Refer to the Fluid-End Service Section. Do not operate the pump with a damaged diaphragm.

CAUTION: Do not leave contaminated oil in the pump housing or leave the housing empty. Remove contaminated oil as soon as discovered, and replace it with clean oil.

Periodically

Change the oil after the first 100 hours of operation, and then according to the guidelines below. When changing, remove the drain plug cap (34) at the bottom of the pump so all oil and accumulated sediment will drain out.

Hours Between Oil Changes @ Various Process Fluid Temperatures

| Pressure | RPM | <90°F (32°C) | <139°F (60°C) | <180°F (82°C) |
|-------------------------------|-------|-----------------|------------------|------------------|
| Metallic Pump Head | | | | |
| <650 psi (45 bar) | <800 | 6,000 | 4,500 | 3,000 |
| | <1200 | 4,000 | 3,000 | 2,000 |
| <1000 psi (70 bar) | <800 | 4,000 | 3,000 | 2,000 |
| | <1200 | 2,000 | 1,500 | 1,000 |
| Non-Metallic Pump Head | | | | |
| <250 psi (17 bar) | <800 | 4,000 | 3,000 | — |
| | <1200 | 2,000 | 1,500 | — |

NOTE: Minimum oil viscosity for proper hydraulic end lubrication is 16-20 cST (80-100 SSU).

NOTE: Use of an oil cooler is recommended when process fluid and/or hydraulic end oil exceeds 180°F (82°C) for Metallic Pump Head models or when hydraulic end oil exceeds 180°F (82°C) for Non-Metallic Pump Head models.

CAUTION: Do not turn the drive shaft while the oil reservoir is empty.

Check the inlet pressure or vacuum periodically with a gauge. If vacuum at the pump inlet exceeds 7 in. Hg (180 mm Hg), check the inlet piping system for blockages. If the pump inlet is located above the supply tank, check the fluid supply level and replenish if too low.

CAUTION: Protect the pump from freezing. Refer also to the "Shutdown Procedure".

Shutdown Procedure During Freezing Temperatures

Take all safety precautions to assure safe handling of the fluid being pumped. Provide adequate catch basins for fluid drainage and use appropriate plumbing from drain ports, etc. when flushing the pump and system with a compatible antifreeze.

1. Adjust the discharge pressure regulating valve so the pump runs under minimum pressure. Stop the pump.
2. Drain supply tank; open any draincocks in system piping and collect drainage; remove plug (4) from manifold and collect drainage.
3. Close draincocks in system piping and replace manifold plug.
4. Fill supply tank with enough antifreeze to fill system piping and pump.

NOTE: Disconnect the system return line from the supply tank and connect it to a separate reservoir.

5. Start the pump and allow it to run until the system is filled with antifreeze. **NOTE:** If the system has an airlock and the pump fails to prime, follow step 4 of the Initial Start-Up Procedure to clear the air.
6. When mostly antifreeze is flowing from the system return line stop the pump. Connect the system return line back to the supply tank and circulate the antifreeze for a short period.
7. It is also good practice to change the oil in the hydraulic end before storage for an extended period. This will remove any accumulated condensation and sediment from the oil reservoir. Drain and refill the hydraulic end with the appropriate Hydra-Oil and operate the pump for a short period to assure smooth performance.

G/H-25 Service (Fluid End)

Models with Non-Metallic Pump Head

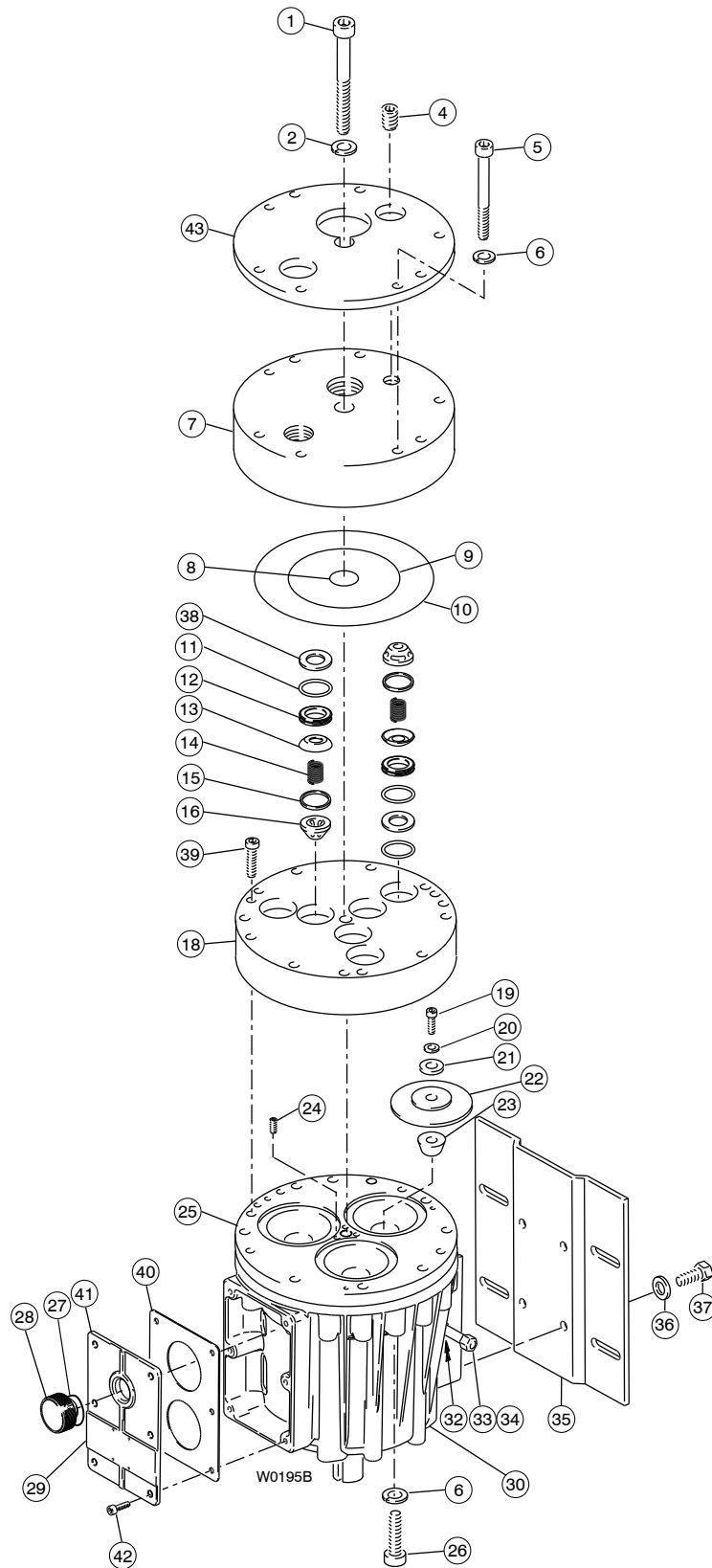

G/H-25 Service (Fluid End)

Models with Metallic Pumping Head

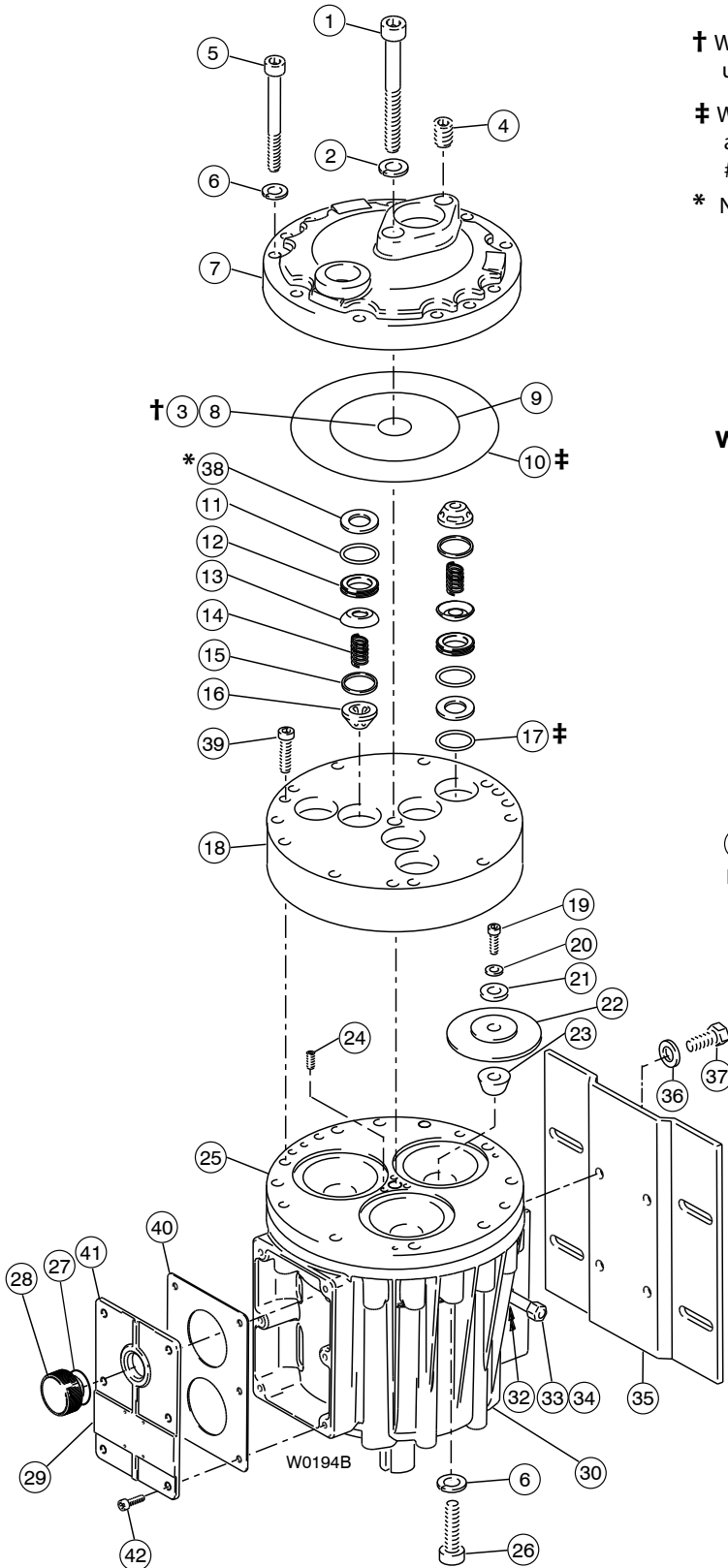

† With brass external-centerbolt models, use #8; with all other models, use #3.

‡ With cast iron pump heads, use #17 and not #10; with all other heads, use #10 and not #17.

* Not included with brass pump heads.

Valve Assemblies with metal spring retainers

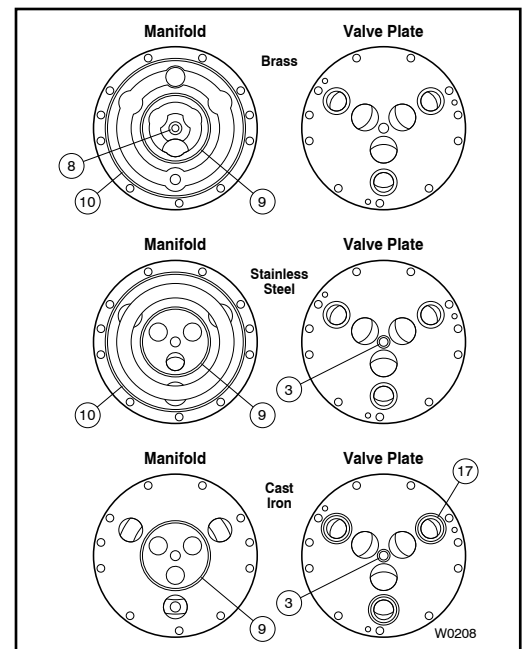
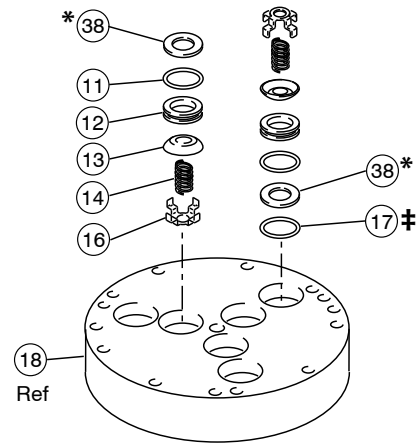

G/H-25 Service (Fluid End)

NOTE: The numbers in parentheses refer to the parts illustrations.

This section explains how to disassemble and inspect all easily-serviceable parts of the pump. Repair procedures for the hydraulic end (oil reservoir) of the pump are included in a later section of the manual.

CAUTION: Do not disassemble the hydraulic end unless you are a skilled mechanic. For assistance, contact Wanner Engineering (TEL 612-332-5681 or FAX 612-332-6937) or the distributor in your area.

CAUTION: The four bolts (26) that screw through the back of the housing into the cylinder casting hold the casting over the hydraulic end of the pump. Do not remove them except when repairing the hydraulic end.

1. Remove Manifold (7), and Valve Plate (18)

a. Remove all bolts (5) and lockwashers (6) around manifold (7). Do not remove four bolts (26) that are installed through back of pump housing (30).

b. With 3/8-in (10-mm) hex Allen wrench, remove centerbolt (1) and washer (2) in center of manifold.

CAUTION: Do not turn the pump drive shaft while the manifold and valve plate are off the pump, except when removing diaphragms or repriming the hydraulic cells.

c. Remove manifold (7) and support plate (43, used on non-metallic pump only).

d. Inspect manifold for warping or wear around inlet and outlet ports. If wear is excessive, replace manifold.

To check for warped manifold, remove O-rings and place straightedge across it. If warped replace.

e. Remove three socket-head cap screws (39) with 3/16-in. (5-mm) hex Allen wrench.

f. Inspect valve plate (18) for warping as in step d for manifold. If warped replace.

NOTE: Plastic valve plates and manifolds should also be inspected for cracks, and replaced as necessary.

2. Inspect Valve Assemblies (parts 11-16, and 38)

NOTE: The three inlet and three outlet valve assemblies in the pump are identical (but face in opposite directions).

Inspect each valve assembly as follows:

- Check spring retainer (16), and replace if worn.
- Check valve spring (14). If shorter than new spring, replace. (Don't stretch old spring.)
- Check valve poppet (13). If worn, replace.

NOTE: If pump has plastic spring retainers, there is a tetra seal O-ring (15) between the retainer (16) and valve seat (12).

- Remove valve seat (12). (Seat remover is included in Wanner Tool Kit.) On cast iron valve plates, be careful not to break metal ridge around O-ring groove.

Inspect valve seat for wear. If worn, replace and install new O-ring (11).

- Reinstall valve assemblies:

- Clean valve ports and valve shoulders with emery cloth, and grease with lubricating gel or petroleum jelly.
- Install O-ring (11) on valve seat (12).

NOTE: Some pumps use plastic dampening washers (38) between the valve seat (12) and the manifold (7) or valve plate (18). Refer to the parts illustrations and the fluid-end exploded views in the Parts Manual.

- Inlet (3 center valves).** Insert retainer (16) into valve plate (18), then spring (14), valve (13), and valve seat (12). If pump has **plastic** retainers, O-ring (15) goes between retainer and seat.

- Outlet (3 outer valves).** Insert valve seat (12), valve (13), and spring (14), then retainer (16). If pump has **plastic** retainers, install the O-ring (15) between retainer and seat. If pump has **metal** retainers in outlet valves, position them so leg does not point toward center of pump. See illustration following.

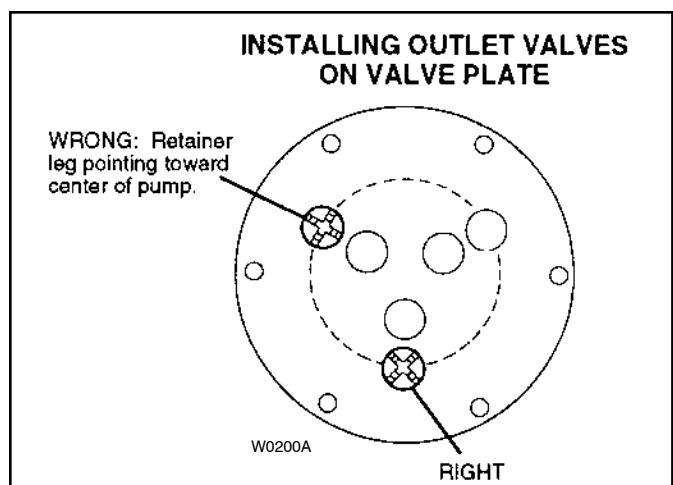

G/H-25 Service (Fluid End)

3. Inspect and Replace Diaphragms (22)

- a. Lift diaphragm (22) by one edge, and turn pump shaft until diaphragm pulls up. This will expose machined cross holes in valve plunger shaft behind diaphragm.
- b. Insert Allen wrench through one of holes, to hold diaphragm up. (The proper size tool is included in the Wanner Tool Kit.)
- c. Remove screw (19), O-ring (20), and follower (21) in center of diaphragm.
- d. Remove diaphragm and inspect carefully.

NOTE: A ruptured diaphragm indicates a pumping system problem, and replacing only the diaphragm will not solve the larger problem.

Inspect diaphragm (22) for following:

- **Half-moon marks.** Usually caused by cavitation of pump (See Troubleshooting section).
 - **Concentric circular marks.** Usually caused by cavitation of pump (See Troubleshooting section).
 - **Small puncture.** Usually caused by sharp foreign object in fluid, or by ice particle.
 - **Diaphragm pulled away** from center screw or from cylinder sides. Usually caused by fluid being frozen in pump, or by overpressurization of pump.
 - **Diaphragm stiff and inflexible.** Usually caused by pumping fluid incompatible with diaphragm material, or diaphragm operated at temperatures below rated capability.
 - **Diaphragm edge chewed away.** Usually caused by overpressurizing system.
- f. Inspect plunger (23) for any rough surfaces or edges. Do not remove plunger from valve plunger (54). Smooth surfaces and edges as necessary with emery cloth or fine file.

CAUTION: If a diaphragm has ruptured and foreign material or water has entered the oil reservoir, do not operate the pump. Check all diaphragms, then flush the reservoir completely (as outlined below) and refill it with fresh oil. Never let the pump stand with foreign material or water in the reservoir, or with the reservoir empty.

- g. Install new diaphragm (22) or reinstall old diaphragm (if good) ridge side out.
- h. Clean screw (19) including any oil. Apply medium-strength threadlocker to screw. Reinstall screw, follower (21), and new O-ring (20). Tighten to 18 in.-lbs (2.0 N-m).
- i. Repeat steps a. thru h. for other two diaphragms (22). Replace diaphragms if indicated.

4. Flush Contaminant from Hydraulic End (use if diaphragm has ruptured)

- a. Remove oil drain cap (34) and allow all oil and contaminants to drain out. Replace oil drain cap.
- b. Remove oil cap (28) and fill reservoir with kerosene or solvent, manually turn pump shaft to circulate kerosene, and drain.

CAUTION: If you have EPDM diaphragms, or if food grade oil is in the reservoir, do not use kerosene or solvents. Instead, flush with the same lubricant used in the reservoir. Pumps with EPDM diaphragms have an "E" as the 7th digit of the Model No.

- c. Repeat step b.
- d. Fill reservoir with fresh oil, manually turn pump shaft to circulate oil, and drain once again.
- e. Refill reservoir. If oil appears milky, there is still contaminant in reservoir. Repeat flushing procedure until oil appears clean.
- d. Replace oil cap (28).

5A. Prime Hydraulic Cells on Standard Pumps

- a. With pump horizontal, and fluid-end head removed, remove oil cap (28) and fill reservoir with correct Hydraulic oil for application. Have catch basin for oil leaks from behind diaphragms when priming. Catch oil and dispose of properly. **Do not reuse.**
- b. Force air out of oil in hydraulic cell (behind diaphragms) by turning shaft and pumping piston. (A shaft rotator is included in the Wanner Tool Kit.) Turn shaft until bubble-free flow of oil comes from behind all diaphragms. Watch oil level in reservoir. If oil gets too low during priming, air will be drawn into pistons (inside hydraulic end) and cause pump to run rough.
- c. Wipe excess oil from cylinder housing (25) and diaphragms (22).
- d. Ensure that oil is one inch (25 mm) from top of fill port.
- e. Replace oil cap (28).

5B. Prime Hydraulic Cells on Kel-Cell Pumps

NOTE: Providing oil prime to Kel-Cell fitted pumps requires pressure be applied to the diaphragms. This can be done manually, with the system head pressure, or with pressurized air if available. Review all methods below to determine the procedure most suitable.

G/H-25 Service (Fluid End)

5B. Prime Hydraulic Cells on Kel-Cell Pumps (Cont'd)

Method #1 (with system head pressure less than 2 psi)

- a. Install valve plate (18) without outlet valves (leave seats (12) installed) onto cylinder housing (25). Tighten two socket-head screws (39).
- b. Remove oil cap (28) and fill reservoir with correct Hydra-oil to top of fill port.
- c. With blunt pointer (eraser end of pencil), reach in through each outlet valve port and push follower-diaphragm backwards. Note air bubbles coming out at oil fill port. Now turn shaft about 1/2 turn.
- d. Repeat depressing diaphragms and rotating shaft (approximately 4 to 6 times) until no more air bubbles escape and oil has dropped about 1 inch (25 mm) from top of fill port. Hydraulic cells are now primed. Replace oil cap (28).
- e. Install outlet valve assemblies in each outlet valve port. See parts illustration for correct assembly order. You may have to tip pump (head upward) in order to keep valve centered on seat (12) and allow retainer (16) to fit flush in port.
- f. Install manifold (7) and complete installation.

Method #1 Alternative (with system head pressure less than 2 psi)

- a. With pump horizontal, and fluid-end head removed, remove oil cap (28) and fill reservoir with correct Hydra-oil. Have catch basin for oil leaks from behind diaphragms when priming. Catch oil and dispose of properly. **Do not reuse.**
- b. Force air out of oil in hydraulic cell (behind diaphragms) by turning shaft and pumping piston. (A shaft rotator is included in the Wanner Tool Kit.) Keep pressure on diaphragms while turning shaft until bubble-free flow of oil comes from behind all diaphragms. Watch oil level in reservoir. If oil gets too low during priming, air will be drawn into pistons (inside hydraulic end) and cause pump to run rough.
- c. Quickly attach assembled valve plate (18) (before oil runs out past diaphragms) with socket head screw (39). Do not tighten screw completely. Leave gap between valve plate and cylinder housing (25). Turn shaft 2-3 turns to force out any remaining air behind diaphragms. Hydraulic cells are now primed. Complete valve plate installation with two socket head screws (39) and add pump manifold (7).
- d. Wipe off excess oil from around pump head.
- e. Check that oil level is 1 inch (25 mm) from top of fill port.
- f. Replace oil cap (28) and complete installation.

Method #2 (with system head pressure greater than 2 psi)

NOTE: This simple and clean method of priming the

Hydra-cells requires an inlet head pressure of at least 5 feet (1.5 m) or 2 psi (.14 bar). This pressure is required to hold the diaphragms back while the piston moves to force out the air.

- a. Completely assemble pump.
- b. Remove oil cap (28) and fill reservoir with correct Hydra-oil to top of fill port.

When tank head pressure is being used to prime, use the following steps:

- c. Install pump in system and connect tank supply line to pump inlet. Connect pump discharge line. Leave end of line open to allow air to pass out.
- d. Slowly turn pump shaft by hand and watch for bubbles at oil reservoir fill opening. This will take several rotations. When no more bubbles come out and reservoir level has dropped about 1" (25 mm), hydraulic cells are primed.
- e. Replace oil cap (28) and complete installation.

When compressed air is being used to prime, use the following steps:

- c. Insert clean air hose to pump inlet and restrict pump outlet. Turn shaft quarter turn and apply air pressure into manifold to put pressure on diaphragms. Note air bubbles at reservoir opening. Repeat for several rotations until no more air bubbles come out and reservoir level has dropped about 1" (25 mm). Hydraulic cells are now primed.
- d. Replace oil cap (28) and complete installation.

6. Reinstall Valve Plate (18), and Manifold (7)

- a. Install valve assemblies in valve plate (18) as outlined in paragraph 2, step e.
- b. Install valve plate (18) on cylinder housing (25) with three cap screws (39).
- c. Reinstall O-rings (8, 9, and 10) between valve plate and manifold (7). (See illustrations to determine which O-rings to use depending on pumping head material.) Use petroleum jelly or lubricating gel to hold them in place.
- d. Reinstall manifold (7) onto valve plate (18). Be sure drain plug (4) is at bottom of manifold. If pumping head is non-metallic, support plate (43) is also used.
- e. Insert all bolts (5), washers (6), and nuts (31) around edge of manifold, and centerbolt (1) with washer (2). Hand tighten.
- f. **H-25 (external centerbolt models only).** Install centerbolt (1), with washer (2), and tighten. Torque to 60 N-m.

For Model H-25

- g. Torque centerbolt to 45 ft-lbs.
- h. Alternately tighten opposite bolts (5) until all are secure. Torque to 45 ft-lbs.

For Model G-25

- g. Alternately tighten opposite bolts (5) until all are secure. Torque to 60 N-m.
- h. Torque centerbolt to 60 N-m.

G/H-25 Service (Hydraulic End)

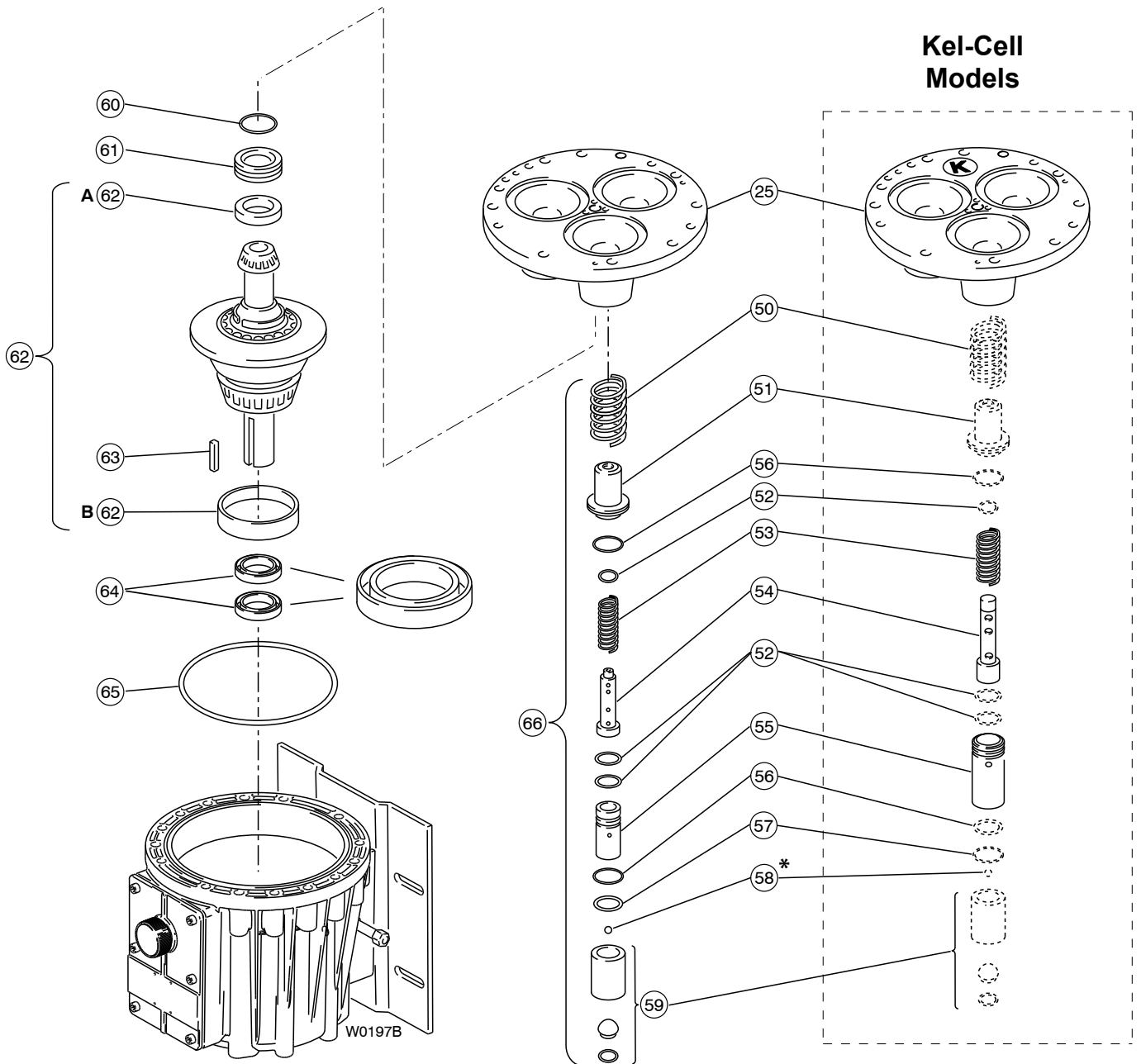

G/H-25 Service (Hydraulic End)

NOTE: The numbers in parentheses are the Reference Numbers used in the Parts Manual illustrations.

CAUTION: Do not disassemble the hydraulic end unless you are a skilled mechanic. For assistance, contact Wanner Engineering (TEL 612-332-5681 or FAX 612-332-6937) or the distributor in your area.

CAUTION: The four socket head screws (26) that screw through the back of the pump housing (30) into the cylinder housing (25) hold the cylinder housing to the pump housing. Do not remove them except when repairing the hydraulic end.

NOTE: The following service procedures refer several times to the Wanner Tool Kit. We strongly urge you not to try to repair the hydraulic end of the pump without using the tools in this kit (available from Wanner or your local distributor).

1. Disassemble Pump Housing (30) and Cylinder Housing (25)

- Remove pump head and diaphragms (22) as outlined in Fluid-End Service Section.
- Remove cap (34) and drain oil from pump housing.
- Set hydraulic end of pump face-down on cylinder housing (25).
- Check cam assembly shaft (62) for sharp burrs. Smooth any burrs. Burrs can scar seals (64) during pump disassembly.
- Remove four socket head screws (26) and washers (6) that secure cylinder housing to pump housing (30). Piston return springs (50) will force cylinder housing and pump housing apart.
- Lift off pump housing.
- Inspect cam assembly and bearings (62). Inspect bearing race in rear of pump housing (30). If bearings are pitted or binding, or if housing race is worn, contact Wanner Engineering.

2. Disassemble Pistons (66)

- With pump housing removed (see above), turn unit over and set it on flat surface, piston side down.
- With diaphragms (22) removed (see Fluid-End Service Section), reinsert screw (19) into hole in one of valve plungers (54). Tap screw lightly with hammer. Plunger (23) should slip off valve plunger (54). Disassemble hydraulic piston assembly (66). Inspect all parts, and replace all O-rings (52, 56) and any other parts that are worn or damaged.
- Repeat step b. for remaining two pistons.

NOTE: Use new plungers (23) to reassemble hydraulic piston. They are press-fit onto the valve plungers (54) and are not reusable.

3. Reassemble Pistons (66)

- Drop ball (58) into each opening in bottom of piston assembly (59).
- Insert retaining washer (57) and O-ring (56) to hold ball in place.
- Insert valve plunger (54) into valve cylinder (55). Slide spring (53) over plunger, inside valve cylinder.
- Insert O-ring (52) into spring retainer (51).
- Install two O-rings (52) on valve cylinder (55).
- Slide assembled valve cylinder, plunger, and spring into spring retainer (51).
- Install O-ring (56) on spring retainer.
- Slide complete cylinder and retainer assembly (51-56) into piston assembly (59).
- Insert return spring (50) into piston assembly.
- Repeat above procedure for remaining two pistons.

4. Reassemble Pump Housing (30) and Cylinder Housing (25)

NOTE: Inspect shaft seals (64). If seals are damaged in any way, replace. Remove seals by pounding them out from inside pump housing (30). Both seals should be replaced. Clean seal bore in pump housing, using emery cloth or ScotchBrite™. See Paragraph 5. Replace Shaft Seals.

- Place cylinder housing (25) face-down on flat surface.
- Insert assembled pistons (66) into cylinder housing.
- Note location of outer ring holes in cylinder housing and in flange of pump housing — in particular four holes where cap screws (26) will be installed. Screw two *threaded studs* (from Wanner Tool Kit) into two of four holes in cylinder housing. Use opposite holes.
- Stand camshaft assembly (62) on cylinder housing (25).
CAUTION: The pilot bearing **MUST** be properly nested in the bearing race during assembly. If misaligned, the bearing will be damaged and the pump will fail within the first hours of operation.
- Using grease to retain it, install O-ring (65) and slide pump housing (30) over shaft and onto *threaded studs* in cylinder housing. Be sure holes in pump housing and cylinder housing are correctly aligned.
- Install cap screws (26) and washers (6), but don't tighten.
- Insert two or more bolts (5) into unthreaded holes of pump housing and cylinder housing to help align parts.

G/H-25 Service (Hydraulic End)

- h. Alternately tighten four cap screws to evenly draw pump housing and cylinder housing together. Be sure O-ring (65) stays in place.
- i. While tightening cap screws, frequently check shaft alignment by turning shaft with *rotor* (from Wanner Tool Kit). If shaft begins to bind and is hard to turn, back off cap screws and realign shaft. When pump housing is tight against cylinder housing, shaft should turn smoothly.
- j. After all cap screws are tightened, remove two *threaded studs*.
- k. Turn shaft again to check alignment.

5. Replace Shaft Seals (64)

- a. Apply thin coat of grease to *seal protector tool* (from Wanner Tool Kit). Slide both seals (64) onto tool, with spring side of seals toward open end of tool.
- b. Apply heavy coat of grease between seals and press together.
- c. Apply coating of Loctite® High-Performance Pipe Sealant with PTFE, or comparable product to outer surface of both seals and inside surface of shaft opening in pump housing (30).
- d. Apply light film of grease to cam assembly drive shaft (62). Slide *seal protector tool* and seals over end of shaft.
- e. Slide *seal inserter tool* (from Wanner Tool Kit) over *seal protector tool* and press seals into place. Carefully tap *seal inserter tool* with soft mallet to firmly seat seals.

6. Adjust Endplay of Camshaft (62)

- a. Remove and clean three set screws (24) from cylinder housing (25).
- b. Insert centerbolt (1) into center hole of cylinder housing (25).
- c. Turn in centerbolt to move bearing adjusting plate (61) and cup tight against bearing cone.
- d. Back out centerbolt **two** full turns, then turn in until it is tight against adjusting plate (61).
- e. Back out centerbolt **exactly 1/4** turn.
- f. With plastic mallet (or a regular mallet and wooden board) carefully rap end of camshaft (62) three or four times. This will provide about 0.006 in. (0.15 mm) endplay in shaft.
- g. Apply removable threadlocker to threads of three set screws (24) and screw into cylinder housing until they contact bearing adjusting plate.
- h. Remove centerbolt.

7. Install Plungers (23)

NOTE: Install new plungers if they have been removed from the valve plungers (54). Do not reuse.

- a. Rotate pump shaft so piston (66) is in top-dead-center position.
- b. Place plunger (23) on exposed screw end of *plunger guide tool* (from Wanner Tool Kit). Larger-diameter side of plunger should face tool.
- c. Screw *plunger guide tool* with plunger into valve plunger (54) until tight.
- d. Hold single bottom handle of *plunger guide tool*, and turn double top handle to force plunger to seat on valve plunger. Plunger should be tight against shoulder of valve plunger. Plunger is press-fit when installed.
- e. Leave *plunger guide tool* installed.
- f. Install diaphragm as outlined in **Reinstall Diaphragms** paragraph below.

NOTE: Do not remove the *plunger guide* until the diaphragm is installed as outlined in Paragraph 8. Reinstall Diaphragms below.

- g. Repeat steps a. thru f. for two remaining plungers and diaphragms.

8. Reinstall Diaphragms (22)

- a. Insure *plunger guide tool* (from Wanner Tool Kit) is screwed into valve plunger (54) from **Paragraph 7. Install Plungers** above. Pull valve plunger up until cross-holes in valve plunger are exposed.
- b. Insert *plunger holder* (from Wanner Tool Kit) through top hole — to hold plunger (23) away from cylinder housing (25), and keep valve plunger from turning when diaphragm (22) is installed.
- c. Place diaphragm onto plunger, ridge-side out.
- d. Place and center follower (21) on diaphragm.
- e. Place O-ring (20) on screw (19), and apply small amount of threadlocker to threads of screw.
- f. Insert screw with O-ring through follower and diaphragm, and screw it into valve plunger (54).
- g. Grasp *plunger holder* and torque screw to 18 in.-lbs (2.0 N-m).
- h. Remove *plunger holder* and *plunger guide tool*.

9. Reassemble Pump Head

- a. Reassemble pump head as outlined in Fluid-End Service Section.
- b. Fill reservoir with fresh oil and prime pump, as outlined in Fluid-End Service Section.

G/H-25 Troubleshooting

Cavitation

- Inadequate fluid supply because:
 - Inlet line collapsed or clogged
 - Clogged line strainer
 - Inlet line too small or too long
 - Air leak in inlet line
 - Worn or damaged inlet hose
 - Suction line too long
 - Too many valves and elbows in inlet line
- Fluid too hot for inlet suction piping system.
- Air entrained in fluid piping system.
- Aeration and turbulence in supply tank.
- Inlet vacuum too high

Symptoms of Cavitation

- Excessive pump valve noise
- Premature failure of spring or retainer
- Volume or pressure drop
- Rough-running pump
- Premature failure of diaphragms
- Piston return spring failure (inside hydraulic end)

Drop in Volume or Pressure

A drop in volume or pressure can be caused by one or more of the following:

- Air leak in suction piping
- Clogged suction line or suction strainer
- Suction line inlet above fluid level in tank
- Inadequate fluid supply
- Pump not operating at proper RPM
- Relief valve bypassing fluid
- Worn pump valve parts
- Foreign material in inlet or outlet valves
- Loss of oil prime in cells because of low oil level
- Ruptured diaphragm
- Cavitation
- Warped manifold from overpressurized system
- O-rings forced out of their grooves from overpressurization
- Air leak in suction line strainer or gasket
- Cracked suction hose.
- Empty supply tank
- Excessive aeration and turbulence in supply tank
- Worn and slipping drive belt(s)
- Worn spray nozzle(s)
- Cracked cylinder casting

Pump Runs Rough

- Worn pump valves
- Airlock in outlet system
- Oil level low
- Wrong weight of oil for cold operating temperatures (change to lighter weight)
- Cavitation
- Air in suction line
- Restriction in inlet/suction line
- Hydraulic cells not primed after changing diaphragm
- Foreign material in inlet or outlet valve
- Damaged diaphragm
- Fatigued or broken valve spring
- Broken piston return spring (inside hydraulic end)

Premature Failure of Diaphragm

- Frozen pump
- Puncture by a foreign object
- Elastomer incompatible with fluid being pumped
- Pump running too fast
- Excess pressure
- Cavitation
- Broken piston return spring (50)

Water (or Process Fluid) in Oil Reservoir

- Condensation
- Ruptured diaphragm
- Hydraulic cell not properly primed after diaphragm replacement
- Frozen pump
- Diaphragm screw O-ring (18) missing or cracked
- Cracked cylinder casting

Strong Water (or Process Fluid) Pulsations

NOTE: Small pulsations are normal in single-acting pumps with multiple pumping chambers.

- Foreign object lodged in pump valve
- Loss of prime in hydraulic cell because of low oil level
- Air in suction line
- Valve spring (13) broken
- Cavitation
- Aeration or turbulence in supply tank

G/H-25 Troubleshooting

Valve Wear

- Normal wear from high-speed operation
- Cavitation
- Abrasives in the fluid
- Valve incompatible with corrosives in the fluid
- Pump running too fast

Loss of Oil

- External seepage
- Rupture of diaphragm
- Frozen pump
- Diaphragm screw O-ring (18) missing or cracked
- Worn shaft seal
- Oil drain piping or fill cap loose.
- Valve plate and manifold bolts loose

Premature Failure of Valve Spring or Retainer

- Cavitation
- Foreign object in the pump
- Pump running too fast
- Spring/retainer material incompatible with fluid being pumped
- Excessive inlet pressure.

Limited Warranty

Wanner Engineering, Inc. extends to the original purchaser of equipment manufactured by it and bearing its name, a limited one-year warranty from the date of purchase against defects in material or workmanship, provided that the equipment is installed and operated in accordance with the recommendations and instructions of Wanner Engineering, Inc. Wanner Engineering, Inc. will repair or replace, at its option, defective parts without charge if such parts are returned with transportation charges prepaid to Wanner Engineering, Inc., 1204 Chestnut Avenue, Minneapolis, Minnesota 55403.

This warranty does not cover:

1. The electric motors (if any), which are covered by the separate warranties of the manufacturers of these components.
2. Normal wear and/or damage caused by or related to abrasion, corrosion, abuse, negligence, accident, faulty installation or tampering in a manner which impairs normal operation.
3. Transportation costs.

This limited warranty is exclusive, and is in lieu of any other warranties (express or implied) including warranty of merchantability or warranty of fitness for a particular purpose and of any noncontractual liabilities including product liabilities based on negligence or strict liability. Every form of liability for direct, special, incidental or consequential damages or loss is expressly excluded and denied.



WANNER ENGINEERING, INC.

1204 Chestnut Avenue, Minneapolis, MN 55403
TEL: (612) 332-5681 FAX: (612) 332-6937
TOLL-FREE FAX [US only]: (800) 332-6812

www.hydra-cell.com
email: sales@wannereng.com

© 2004 Wanner Engineering, Inc. Printed in USA
G25-991-2400B 5/2004, Revised 8/2007