

Model 2196 LF Interchangeability and Dimensional Data

Parts interchangeable with **SUMMIT™ 2196**

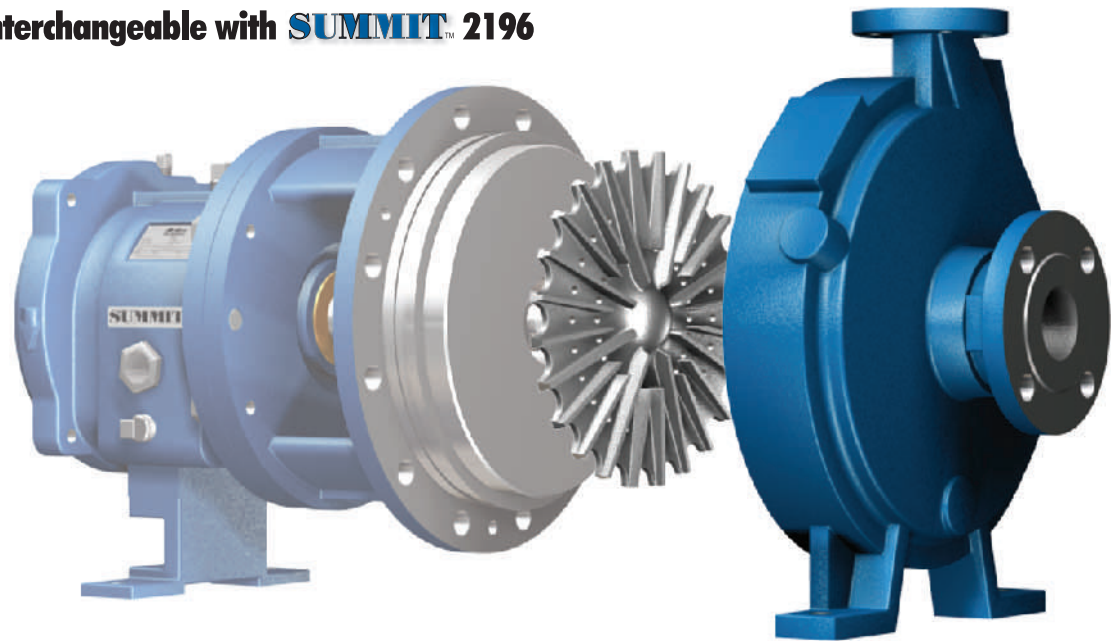

2196 LF STO

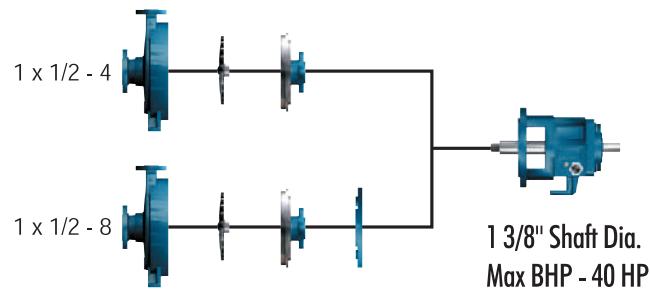

2196 LF MTO/LTO

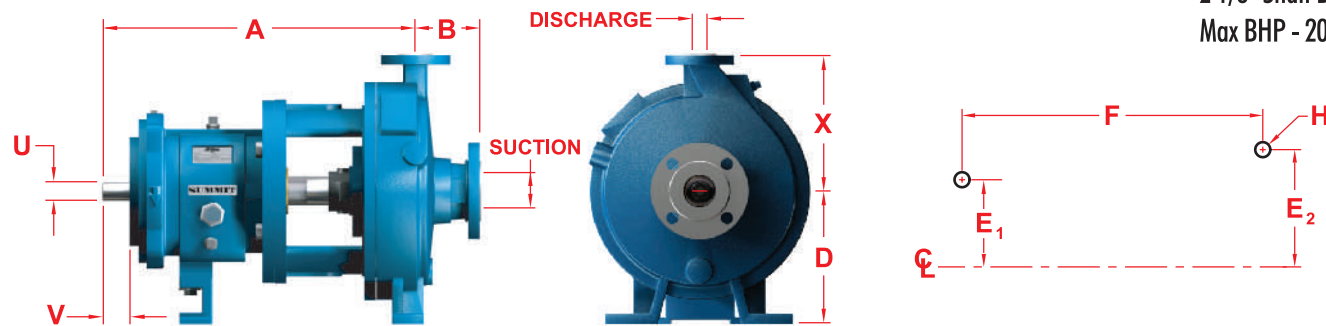
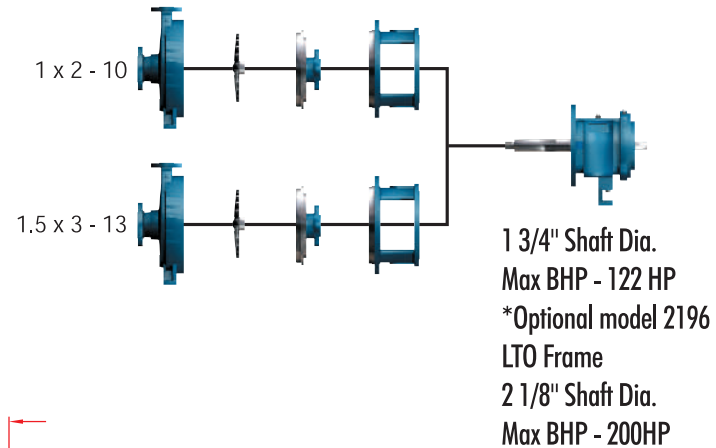

PUMP DIMENSIONS

Pump Frame	Pump Size	Dis.	Suc.	X	A	B	D	Foot Pattern				Shaft		Bare Pump Weight(lbs.)	
								E1	E2	F	H	U	Keyway		V
STO	1X1.5-4	1	1.5	6.5	13.5	4	5.25	3	0	7 1/4	5/8	.875	3/16 X 3/32	2	85
	1X1.5-8	1	1.5												100
MTO	1X2-10	1	2	8.5	19.5	4	8.25	4 7/8	3 5/8	12 1/2	5/8	1.125	1/4 X 1/8	2 5/8	200
LTO												1.875	1/2 X 1/4		250
LTO	1.5X3-13	1.5	3	10.5	19.5	4	10	4 7/8	3 5/8	12 1/2	5/8	1.875	1/2 X 1/4	2 5/8	290

SUMMIT™

2196 LF

2196LF



Low Flow High Head Pump



**SUMMIT™
PUMP, Inc**

www.SUMMITPUMP.com

2196LF Low Flow High Head Pump

Applications

Additive Chemicals
Batch/Continuous Chemical Reactors
Chemical Dryers
Chemical Process
Condensate Service

Evaporators
Petro Chemical Service
Prototype Processes
Shower Service
Seal Water

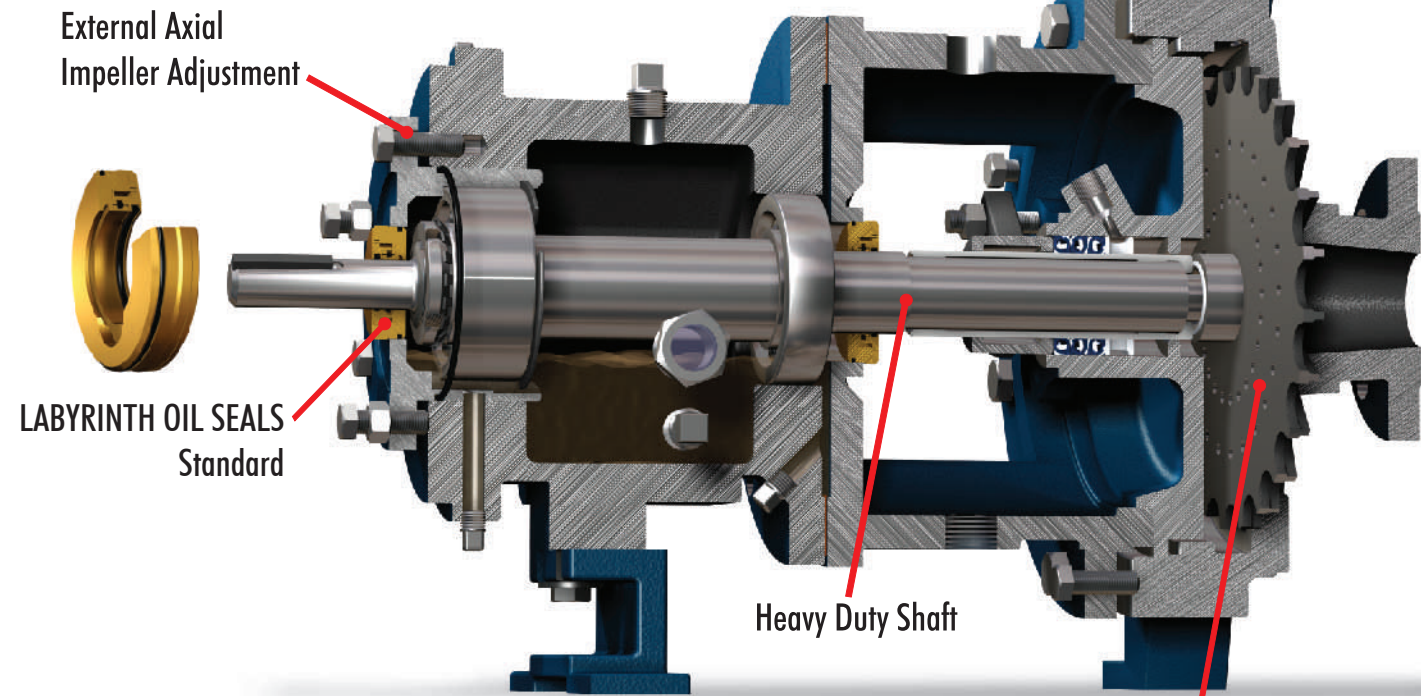

Open/Non-Clogging Radial Vane Impeller with Balance Holes

Features

Radial vane impeller with balance holes
Interchangeability with existing ANSI pumps
Circular non-expanding case

Benefits

Reduced shaft vibration
Lower NPSHr
Lower seal chamber pressure
Extended MTBF on the pump and mechanical seals

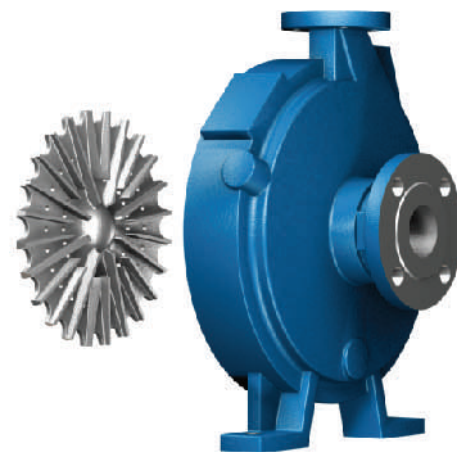

Designed Specifically for Trouble-Free Operation at Low Flows

Summit's 2196LF pump replaces high cost and high maintenance horizontal split case pumps. The Summit 2196LF is built on the ANSI principle with only one seal chamber. With a simple impeller adjustment, you can renew decreased pump performance without contending with close-tolerance wear rings.

Performance

